

ETSI EN 300 132-3 V2.3.1 (2023-01)



**Environmental Engineering (EE);
Power supply interface at the input of
Information and Communication Technology (ICT) equipment;
Part 3: Up to 400 V Direct Current (DC)**

[ETSI EN 300 132-3 V2.3.1 \(2023-01\)](https://standards.iteh.ai/catalog/standards/sist/9f8b4198-feeb-4cc9-b6d6-1736cd5f9ab2/etsi-en-300-132-3-v2-3-1-2023-01)

<https://standards.iteh.ai/catalog/standards/sist/9f8b4198-feeb-4cc9-b6d6-1736cd5f9ab2/etsi-en-300-132-3-v2-3-1-2023-01>

Reference

REN/EE-02103

Keywords

environment, interface, power supply

ETSI

650 Route des Lucioles
F-06921 Sophia Antipolis Cedex - FRANCE

Tel.: +33 4 92 94 42 00 Fax: +33 4 93 65 47 16

Siret N° 348 623 562 00017 - APE 7112B
Association à but non lucratif enregistrée à la
Sous-Préfecture de Grasse (06) N° w061004871

Important notice

The present document can be downloaded from:
<http://www.etsi.org/standards-search>

The present document may be made available in electronic versions and/or in print. The content of any electronic and/or print versions of the present document shall not be modified without the prior written authorization of ETSI. In case of any existing or perceived difference in contents between such versions and/or in print, the prevailing version of an ETSI deliverable is the one made publicly available in PDF format at www.etsi.org/deliver.

Users of the present document should be aware that the document may be subject to revision or change of status. Information on the current status of this and other ETSI documents is available at <https://portal.etsi.org/TB/ETSIDeliverableStatus.aspx>

If you find errors in the present document, please send your comment to one of the following services:
<https://standards.etsi.org/People/CommitteeSupportStaff.aspx>

If you find a security vulnerability in the present document, please report it through our Coordinated Vulnerability Disclosure Program:
<https://www.etsi.org/standards/coordinated-vulnerability-disclosure>

Notice of disclaimer & limitation of liability

The information provided in the present deliverable is directed solely to professionals who have the appropriate degree of experience to understand and interpret its content in accordance with generally accepted engineering or other professional standard and applicable regulations.

No recommendation as to products and services or vendors is made or should be implied. In no event shall ETSI be held liable for loss of profits or any other incidental or consequential damages.

Any software contained in this deliverable is provided "AS IS" with no warranties, express or implied, including but not limited to, the warranties of merchantability, fitness for a particular purpose and non-infringement of intellectual property rights and ETSI shall not be held liable in any event for any damages whatsoever (including, without limitation, damages for loss of profits, business interruption, loss of information, or any other pecuniary loss) arising out of or related to the use of or inability to use the software.

Copyright Notification

No part may be reproduced or utilized in any form or by any means, electronic or mechanical, including photocopying and microfilm except as authorized by written permission of ETSI.

The content of the PDF version shall not be modified without the written authorization of ETSI. The copyright and the foregoing restriction extend to reproduction in all media.

© ETSI 2023.
All rights reserved.

Contents

Intellectual Property Rights	5
Foreword.....	5
Modal verbs terminology.....	6
1 Scope	7
2 References	7
2.1 Normative references	7
2.2 Informative references.....	8
3 Definition of terms, symbols and abbreviations.....	8
3.1 Terms.....	8
3.2 Symbols.....	10
3.3 Abbreviations	10
4 Power interface "A3"	11
5 DC interface requirements.....	11
5.0 General	11
5.1 Nominal voltage	11
5.2 Normal service voltage range at interface "A3"	12
5.3 Normal operating voltage range at interface "A3"	12
5.4 Reference test voltage (U_T) at interface "A3".....	12
5.5 Abnormal service voltage ranges at interface "A3".....	12
6 Abnormal conditions: Voltage variations, voltage dips, short interruptions and voltage surges at interface "A3"	13
6.0 General	13
6.1 Voltage variations.....	13
6.2 Voltage dips.....	14
6.3 Short interruptions.....	14
6.4 Voltage surges	15
7 DC Supply protection.....	16
8 Maximum steady state current I_m , in the normal service voltage range	16
9 Inrush current on connection to interface "A3"	17
9.1 Limits	17
9.2 Measurements.....	18
10 Installation and Cabling, Earthing and Bonding	19
11 Electrical Safety requirements.....	19
12 EMC requirements at the input of ICT equipment.....	20
Annex A (informative): Power supply considerations.....	21
Annex B (informative): Identification of interface "A3"	22
Annex C (informative): Calculation of the extreme DC voltage range at interface "A3"	23
Annex D (informative): Guide for defining inrush current energy, measuring inrush current and test generator peak inrush current drive capability.....	24
D.0 General	24
D.1 Measurement	24
D.2 Test generator peak inrush current drive capability	25
D.3 Example of inrush current waveform.....	25

Annex E (informative):	Dimensioning of over-current protective devices.....	27
Annex F (informative):	Details of the voltage transient measurement in the most common case of distribution and protective devices	28
Annex G (informative):	Diagram of voltage ranges and values at the interface "A3"	30
History		31

iTeh STANDARD PREVIEW
(standards.iteh.ai)

[ETSI EN 300 132-3 V2.3.1 \(2023-01\)](https://standards.iteh.ai/catalog/standards/sist/9f8b4198-fee9-4cc9-b6d6-1736cd5f9ab2/etsi-en-300-132-3-v2-3-1-2023-01)

<https://standards.iteh.ai/catalog/standards/sist/9f8b4198-fee9-4cc9-b6d6-1736cd5f9ab2/etsi-en-300-132-3-v2-3-1-2023-01>

Intellectual Property Rights

Essential patents

IPRs essential or potentially essential to normative deliverables may have been declared to ETSI. The declarations pertaining to these essential IPRs, if any, are publicly available for **ETSI members and non-members**, and can be found in ETSI SR 000 314: "*Intellectual Property Rights (IPRs); Essential, or potentially Essential, IPRs notified to ETSI in respect of ETSI standards*", which is available from the ETSI Secretariat. Latest updates are available on the ETSI Web server (<https://ipr.etsi.org/>).

Pursuant to the ETSI Directives including the ETSI IPR Policy, no investigation regarding the essentiality of IPRs, including IPR searches, has been carried out by ETSI. No guarantee can be given as to the existence of other IPRs not referenced in ETSI SR 000 314 (or the updates on the ETSI Web server) which are, or may be, or may become, essential to the present document.

Trademarks

The present document may include trademarks and/or tradenames which are asserted and/or registered by their owners. ETSI claims no ownership of these except for any which are indicated as being the property of ETSI, and conveys no right to use or reproduce any trademark and/or tradename. Mention of those trademarks in the present document does not constitute an endorsement by ETSI of products, services or organizations associated with those trademarks.

DECT™, **PLUGTESTS™**, **UMTS™** and the ETSI logo are trademarks of ETSI registered for the benefit of its Members. **3GPP™** and **LTE™** are trademarks of ETSI registered for the benefit of its Members and of the 3GPP Organizational Partners. **oneM2M™** logo is a trademark of ETSI registered for the benefit of its Members and of the oneM2M Partners. **GSM®** and the GSM logo are trademarks registered and owned by the GSM Association.

Foreword

This European Standard (EN) has been produced by ETSI Technical Committee Environmental Engineering (EE).

The present document concerns the requirements for the interface between Information and Communication Technology (ICT) equipment and its power supply. It includes requirements relating to its stability and measurement. Various other references, detailed measurement and test arrangements are contained in informative annexes.

The introduced interface up to 400 V Direct Current (DC) is considering power consumption increase and equipment power density increase in order to get higher energy efficiency with less material than with low voltage -48 VDC or permanent AC powering solution.

The up to 400 VDC interface could also simplify the use of renewable energy source with DC output such as photovoltaic generator.

The present document is part 3 of a multi-part deliverable covering Environmental Engineering (EE); Power supply interface at the input to Information and Communication Technology (ICT) equipment, as identified below:

- Part 1: "Alternating Current (AC)";
- Part 2: "-48 V Direct Current (DC)";
- Part 3: "Up to 400 V Direct Current (DC)".**

National transposition dates	
Date of adoption of this EN:	18 January 2023
Date of latest announcement of this EN (doa):	30 April 2023
Date of latest publication of new National Standard or endorsement of this EN (dop/e):	31 October 2023
Date of withdrawal of any conflicting National Standard (dow):	31 October 2023

Modal verbs terminology

In the present document "**shall**", "**shall not**", "**should**", "**should not**", "**may**", "**need not**", "**will**", "**will not**", "**can**" and "**cannot**" are to be interpreted as described in clause 3.2 of the [ETSI Drafting Rules](#) (Verbal forms for the expression of provisions).

"**must**" and "**must not**" are **NOT** allowed in ETSI deliverables except when used in direct citation.

iTeh STANDARD PREVIEW
(standards.iteh.ai)

[ETSI EN 300 132-3 V2.3.1 \(2023-01\)](#)

<https://standards.iteh.ai/catalog/standards/sist/9f8b4198-fee9-4cc9-b6d6-1736cd5f9ab2/etsi-en-300-132-3-v2-3-1-2023-01>

1 Scope

The present document contains requirements and measurements methods for the physical interface "A3" that is situated between the power supply system(s) and the power consuming ICT equipment:

- the nominal voltage at power interface "A3" of ICT equipment defined in the present document is DC voltage up to 400 V;
- the output performance of the power equipment including the cable network at the interface "A3";
- the input of the ICT equipment connected to interface "A3".

The DC power can be supplied by a DC output power system e.g. via on-grid AC rectifiers, from DC/DC converters in solar systems, fuel cells, standby generators including a battery backup.

The present document aims at providing compatibility at interface "A3" between the power supply equipment and different ICT equipment (including/monitoring, cooling system, etc.) connected to the same power supply.

The requirements are defined for the purpose of the present document to:

- identify a power supply system with the same characteristics for all ICT equipment defined in the area of application; the area of application may be any location where the interface "A3" is used i.e. telecommunication centres, Radio Base Stations, datacentres and customer premises;
- facilitate interworking of different loads;
- facilitate the standardization of power supply systems for ICT equipment;
- facilitate the installation, operation and maintenance in the same network of ICT equipment and systems from different origins;
- secure robustness against temporary voltage deviations and transients during abnormal conditions.

General requirements for safety and EMC are out of the scope of the present document series unless specific requirement not defined in existing safety or EMC standards.

2 References

2.1 Normative references

References are either specific (identified by date of publication and/or edition number or version number) or non-specific. For specific references, only the cited version applies. For non-specific references, the latest version of the referenced document (including any amendments) applies.

Referenced documents which are not found to be publicly available in the expected location might be found at <https://docbox.etsi.org/Reference>.

NOTE: While any hyperlinks included in the present clause were valid at the time of publication, ETSI cannot guarantee their long term validity.

The following referenced documents are necessary for the application of the present document.

- [1] IEC 60947-2: "Low-voltage switchgear and controlgear - Part 2: Circuit-breakers".
- [2] IEC 60269-1: "Low-voltage fuses - Part 1: General requirements".
- [3] IEC 61000-4-5: "Electromagnetic compatibility (EMC) - Part 4-5: Testing and measurement techniques - Surge immunity test".

- [4] IEC 61000-4-29: "Electromagnetic compatibility (EMC) - Part 4-29: Testing and measurement techniques - Voltage dips, short interruptions and voltage variations on d.c. input power port immunity tests".
- [5] IEC 60898-2: "Electrical accessories - Circuit-breakers for overcurrent protection for household and similar installations - Part 2: Circuit-breakers for AC and DC operation".
- [6] ETSI EN 301 605 (V1.1.1) (2013): "Environmental Engineering (EE); Earthing and bonding of 400 VDC data and telecom (ICT) equipment".
- [7] Recommendation ITU-T L.1207 (2018): "Progressive migration of a telecommunication/information and communication technology site to 400 VDC sources and distribution".
- [8] IEC 60364-4-41: "Low voltage electrical installations - Part 4-41: Protection for safety - Protection against electric shock".
- [9] EN 60445: "Basic and safety principle for man-machine interface, marking and identification- Identification of equipment terminals, conductor terminations and conductors", (produced by CENELEC).
- [10] Recommendation ITU-T L.1203 (2016): "Colour and marking identification of up to 400 VDC power distribution for information and communication technology systems".

2.2 Informative references

References are either specific (identified by date of publication and/or edition number or version number) or non-specific. For specific references, only the cited version applies. For non-specific references, the latest version of the referenced document (including any amendments) applies.

NOTE: While any hyperlinks included in this clause were valid at the time of publication, ETSI cannot guarantee their long term validity.

The following referenced documents are not necessary for the application of the present document but they assist the user with regard to a particular subject area.

- [i.1] ETSI EN 300 132-2: "Environmental Engineering (EE); Power supply interface at the input of Information and Communication Technology (ICT) equipment; Part 2: -48 V Direct Current (DC)".
- [i.2] IEC 60050-601: "International Electrotechnical Vocabulary. Chapter 601: Generation, transmission and distribution of electricity - General".
- [i.3] ETSI EN 300 386: "Telecommunication network equipment; ElectroMagnetic Compatibility (EMC) requirements; Harmonised Standard covering the essential requirements of the Directive 2014/30/EU".
- [i.4] EN 62368-1: "Audio/video, information and communication technology equipment - Part 1: Safety requirements", (produced by CENELEC).

3 Definition of terms, symbols and abbreviations

3.1 Terms

For the purposes of the present document, the following terms apply:

abnormal service voltage ranges: steady-state voltage ranges over which the ICT equipment will not be expected to maintain normal service but will survive undamaged

area of application: any location where the interface "A3" is used

NOTE: I.e. telecommunication centres, Radio Base Stations, datacentres and customer premises.

customer premises: any location which is the sole responsibility of the customer

dual feeding system: independent power systems i.e. two separate power sources (A+B)

high-ohmic distribution system: distribution system in which the equipment is connected separately to the battery with added impedance

NOTE 1: The high impedance can be achieved with long cables and in some cases additional resistors are installed.

NOTE 2: With this distribution the undervoltage effects of fuse blowing transients are reduced on other equipment connected to the battery.

ICT equipment: telecommunication or datacommunication equipment

independent power distribution: redundant power distribution i.e. dual feeders (A+B) from two separate power sources (A+B) or a single power source

NOTE: Equipment having two power feeds is fitted with OR-ing devices or separate power supply units.

interface "A3": power interface at the input terminals of ICT, physical point, at which power supply is connected in order to operate the ICT equipment

IT system: The codes used have the following meanings:

- First letter: Relationship of the power system to earth:
I: all live parts isolated from earth, or one point connected to earth through a high impedance
- Second letter: Relationship of the exposed-conductive-parts of the installation to earth:
T: direct electrical connection of exposed-conductive-parts to earth, independently of the earthing of any point of the power system

NOTE: See ETSI EN 301 605 [6].
<https://standards.iteh.ai/catalog/standards/sist/9f8b4198-fee9-4cc9-b6d6-v2-3-1-2023-01>

load unit: power consuming equipment, that is part of a system block

nominal voltage: value of the voltage by which the electrical installation or part of the electrical installation is designated and identified

NOTE: This definition is based on nominal voltage defined in IEC 60050-601 [i.2].

normal operating condition: typical environmental and powering conditions for operation of ICT equipment, power supply, power distribution and battery

normal operating voltage: typical value of the voltage at "A3" interface within the normal operating voltage range

normal operating voltage range: voltage range at "A3" interface where the system operates most of the time, e.g. in general linked to battery floating voltage

normal service: service mode where ICT equipment operates within its specification

normal service voltage range: range of the steady-state voltage at the "A3" interface over which the equipment will maintain normal service

NOTE: In general this wider than the normal operating voltage range as it includes a part of the battery discharge voltage range.

operating voltage: value of the voltage under normal conditions, at a given instant and a given point ("A3" interface) of the system

power supply network: network interconnecting the power source and the ICT equipment

reference test voltage: voltage used as a reference to define the test voltage in the present document

NOTE: The test voltage may be also a percentage of this voltage.

system block: functional group of ICT equipment depending for its operation and performance on its connection to the same power supply

telecommunication centre: any location where ICT equipment is installed and is the sole responsibility of the operator

3.2 Symbols

For the purposes of the present document, the following symbols apply:

Ω	ohm
k Ω	Kilo ohm
$^{\circ}\text{C}$	Celsius
A	Ampere
di/dt	derivative of a considered current versus time
Hz	Hertz
I	current
I_m	maximum steady state current drain at 260 VDC at interface "A3"
I_{mss}	maximum steady state current drain in the abnormal service voltage range at interface "A3"
I_n	current rating of the over-current protective device
I_p	peak inrush current at interface "A3"
I_{UT}	maximum steady state current drain at U_T at interface "A3"
m	meter
ms	milli seconds
s	seconds
T_{50}	time duration of the inrush current pulse at 50 % of I_p
U_o	output voltage range of a generator
U_T	Reference Test Voltage
V	Volt
W	Watt
μs	micro seconds

3.3 Abbreviations

For the purposes of the present document, the following abbreviations apply:

AC	Alternating Current
B	Battery
CB	Circuit Breaker
CLD	Current Limiting Device
DC	Direct Current
DC/DC	DC converter
EE	Environmental Engineering
EMC	ElectroMagnetic Compatibility
EN	European Standard
EUT	Equipment Under Test
ICT	Information and Communication Technology
PE	Protective Earth
S	manual Switch or contactor
T	current Transducer
VAC	Volts Alternating Current
VDC	Volts Direct Current
VRLA	Valve Regulated Lead Acid

4 Power interface "A3"

The power supply interface "A3" in figure 1, is a physical point to which all the requirements are related. This point is situated at the power input terminals of the ICT equipment.

Examples of configurations in which interface "A3" is identified are given in annex B.

Basic rules for marking of conductors and connectors shall be in accordance with IEC 60445 [9].

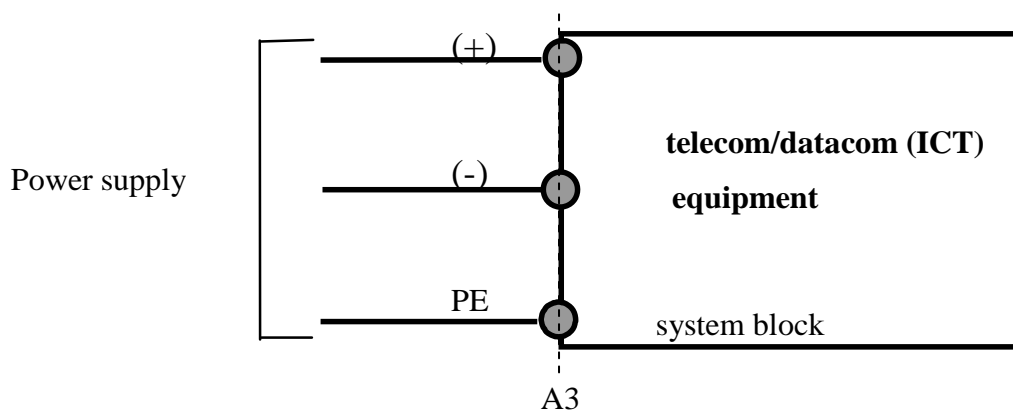

(+) Positive DC terminal.
 (-) Negative DC terminal.
 PE Protective Earth.

Figure 1: General identification of the interface "A3"

5 DC interface requirements

5.0 General

The definition of the DC interface voltages ranges and typical operating voltage values are illustrated in annex G.

5.1 Nominal voltage

The selected battery in general determines this nominal voltage, the operating voltage and the normal service voltage range in the system.

NOTE 1: For example, 336 V is a nominal voltage defined with 168 lead-acid battery cells multiplied by the nominal cell voltage 2 V. This nominal DC voltage is equivalent to 48 V multiplied by 7. It allows the use of existing 48 V battery rack (e.g. Lithium battery racks). There may be other nominal voltage defined with different number of cells e.g. 156 lead-acid battery cells that lead to 312 V nominal voltage. Other battery technologies are possible in the future and will influence nominal voltage as well. For detailed calculation, refer to the annex C.

NOTE 2: In an architecture with a boost converter down-stream the battery, the operating voltage is linked to the Nominal Voltage determined in clause 5.1 provided that converter output voltage is within the Normal Service Voltage range.

5.2 Normal service voltage range at interface "A3"

The normal service voltage range at powering interface "A3" of ICT equipment shall be as follows:

- minimum voltage: 260 VDC;
- maximum voltage: 400 VDC.

NOTE 1: The voltage at the output of the power supply takes into account the voltage drop in the cable at maximum steady current I_m and/or the maximum battery charge to stay in the normal service voltage range at the interface "A3" as explained in annexes A, B, C and G.

NOTE 2: For examples on how to calculate normal service voltage range, refer to annex C.

5.3 Normal operating voltage range at interface "A3"

The normal operating voltage range at interface "A3" is defined by the voltage levels where the system will operate most of the time under normal operating conditions; this range shall be within the normal service voltage range.

The normal operating voltage is a typical voltage inside the normal operating voltage range.

NOTE 1: Examples of normal operating voltages are 354 V and 380 V.
354 V corresponds to 156 VRLA cells in floating mode (351 V to 359 V with 2,25 V to 2,30 V per cell) and with no voltage drop in the power distribution.
380 V corresponds to 168 VRLA cells in floating mode (378 V to 386 V with 2,25 V to 2,30 V per cell) and with no voltage drop in the power distribution.

NOTE 2: For examples on how to calculate normal operating voltage range, refer to annex C.

5.4 Reference test voltage (U_T) at interface "A3"

The reference test voltage (U_T) for ICT equipment is defined at:

$$U_T = 365 \text{ V} \pm 15 \text{ V}$$

NOTE: The powering solution should work in any site even with very long power cables i.e. U_T at the input of ICT equipment is lower than power supply output. For constant power ICT equipment, the current is increasing as a function of decreasing voltage.

5.5 Abnormal service voltage ranges at interface "A3"

The ICT equipment may be subjected to steady state voltage out of the normal service voltage range. Limits of abnormal service voltage range are defined as follows:

- $0 \text{ V} < U < 260 \text{ V}$
- $400 \text{ V} < U < 410 \text{ V}$ for 1 s
- $410 \text{ V} < U < 420 \text{ V}$ for maximum 10 ms

For example, it may be generated from undervoltage or overvoltage at battery end of discharge cycle or battery end of charge or rectifier regulation/control failures.

ICT equipment with interface "A3" shall not suffer any damage when subjected to the abnormal voltage range.

After the restoration of the supply from the abnormal service voltage range to the normal service voltage range, the ICT equipment shall fulfil the following performance criteria:

- the ICT equipment shall not suffer any damage;
- the ICT equipment shall be able to automatically resume operation according to its specifications when the voltage comes back into the normal service voltage range.