

---

---

**Building construction machinery and  
equipment — Concrete mixers —**

**Part 2:  
Procedure for examination of mixing  
efficiency**

**iTeh STANDARD PREVIEW**  
**(standards.iteh.ai)**  
*Machines et matériels pour la construction des bâtiments —  
Malaxeurs de béton —  
Partie 2: Mode opératoire pour la détermination de l'efficacité de  
malaxage*

[ISO 18650-2:2014](https://standards.iteh.ai/catalog/standards/sist/c8dB4fa-3167-4e7f-86b4-ffb351c6d88/iso-18650-2-2014)

[https://standards.iteh.ai/catalog/standards/sist/c8dB4fa-3167-4e7f-86b4-  
ffb351c6d88/iso-18650-2-2014](https://standards.iteh.ai/catalog/standards/sist/c8dB4fa-3167-4e7f-86b4-ffb351c6d88/iso-18650-2-2014)



**iTeh STANDARD PREVIEW**  
**(standards.iteh.ai)**

ISO 18650-2:2014

<https://standards.iteh.ai/catalog/standards/sist/c8d34fa-3167-4e7f-86b4-ffb351c6d88/iso-18650-2-2014>



**COPYRIGHT PROTECTED DOCUMENT**

© ISO 2014

All rights reserved. Unless otherwise specified, no part of this publication may be reproduced or utilized otherwise in any form or by any means, electronic or mechanical, including photocopying, or posting on the internet or an intranet, without prior written permission. Permission can be requested from either ISO at the address below or ISO's member body in the country of the requester.

ISO copyright office  
Case postale 56 • CH-1211 Geneva 20  
Tel. + 41 22 749 01 11  
Fax + 41 22 749 09 47  
E-mail [copyright@iso.org](mailto:copyright@iso.org)  
Web [www.iso.org](http://www.iso.org)

Published in Switzerland

# Contents

	Page
Foreword.....	iv
Introduction.....	v
<b>1 Scope.....</b>	<b>1</b>
<b>2 Normative references.....</b>	<b>1</b>
<b>3 Terms and definitions.....</b>	<b>1</b>
<b>4 Requirements for mixer verified.....</b>	<b>1</b>
<b>5 Mixing performance test.....</b>	<b>2</b>
5.1 General.....	2
5.2 Concrete mix preparation.....	3
5.3 Sampling.....	3
5.4 Variance tests.....	9
<b>6 Evaluation of test results.....</b>	<b>13</b>
<b>7 Test report.....</b>	<b>13</b>
<b>8 Final remarks.....</b>	<b>17</b>
8.1 Filling ratio of tested mixer.....	17
8.2 Optimization of mixing time.....	17
<b>Bibliography.....</b>	<b>19</b>

**iTeh STANDARD PREVIEW**  
**(standards.iteh.ai)**

[ISO 18650-2:2014](https://standards.iteh.ai/catalog/standards/sist/c8d34fa-3167-4e7f-86b4-ffb351c6d88/iso-18650-2-2014)

<https://standards.iteh.ai/catalog/standards/sist/c8d34fa-3167-4e7f-86b4-ffb351c6d88/iso-18650-2-2014>

## Foreword

ISO (the International Organization for Standardization) is a worldwide federation of national standards bodies (ISO member bodies). The work of preparing International Standards is normally carried out through ISO technical committees. Each member body interested in a subject for which a technical committee has been established has the right to be represented on that committee. International organizations, governmental and non-governmental, in liaison with ISO, also take part in the work. ISO collaborates closely with the International Electrotechnical Commission (IEC) on all matters of electrotechnical standardization.

The procedures used to develop this document and those intended for its further maintenance are described in the ISO/IEC Directives, Part 1. In particular the different approval criteria needed for the different types of ISO documents should be noted. This document was drafted in accordance with the editorial rules of the ISO/IEC Directives, Part 2. [www.iso.org/directives](http://www.iso.org/directives)

Attention is drawn to the possibility that some of the elements of this document may be the subject of patent rights. ISO shall not be held responsible for identifying any or all such patent rights. Details of any patent rights identified during the development of the document will be in the Introduction and/or on the ISO list of patent declarations received. [www.iso.org/patents](http://www.iso.org/patents)

Any trade name used in this document is information given for the convenience of users and does not constitute an endorsement.

For an explanation on the meaning of ISO specific terms and expressions related to conformity assessment, as well as information about ISO's adherence to the WTO principles in the Technical Barriers to Trade (TBT) see the following URL: Foreword - Supplementary information

The committee responsible for this document is ISO/TC 195, *Building construction machinery and equipment*, Subcommittee SC 1, *Machinery and equipment for concrete work*.

This second edition cancels and replaces the first edition (ISO 18650-2:2006), of which it constitutes a minor revision. The main changes are:

- updated normative references in [Clause 2](#);
- notes added to [Clause 4](#) re requirements for mixer verified;
- an alternative coarse aggregates size added to [5.2](#);
- notes added to [Figure 3](#);
- mesh screen/coarse aggregate modified size in [5.4.1.1 d](#)), [Figure 7](#), [5.4.1.3](#), [Tables 1](#) and [4](#);
- corrected intersections on regression curves in [Figure 8](#).

ISO 18650 consists of the following parts, under the general title *Building construction machinery and equipment — Concrete mixers*:

- *Part 1: Vocabulary and general specifications*
- *Part 2: Procedure for examination of mixing efficiency*

## Introduction

This part of ISO 18650 deals with the testing of the mixing capabilities of concrete mixers, characterized as the recommended mixing time.

The test consists of the determination of the variance of the mortar, coarse aggregate and air content, and the consistency of concrete mix samples, drawn after an assumed mixing time.

Compressive strength is also tested.

The measure of a concrete mixer's efficiency is the value of the variance of the above parameters, after the assumed mixing time.

This part of ISO 18650 provides for the preparation of concrete mix, sampling, execution of particular tests, criteria of test result evaluation and the test report.

## iTeh STANDARD PREVIEW (standards.iteh.ai)

[ISO 18650-2:2014](https://standards.iteh.ai/catalog/standards/sist/c8d34fa-3167-4e7f-86b4-ffb351c6d88/iso-18650-2-2014)

<https://standards.iteh.ai/catalog/standards/sist/c8d34fa-3167-4e7f-86b4-ffb351c6d88/iso-18650-2-2014>

**iTeh STANDARD PREVIEW**  
**(standards.iteh.ai)**

[ISO 18650-2:2014](#)

<https://standards.iteh.ai/catalog/standards/sist/c8d34fa-3167-4e7f-86b4-ffb351c6d88/iso-18650-2-2014>

# Building construction machinery and equipment — Concrete mixers —

## Part 2: Procedure for examination of mixing efficiency

### 1 Scope

This part of ISO 18650 specifies the procedure and requirements for examination of the mixing efficiency of batch-type and continuous-type concrete mixers as defined in ISO 18650-1. It is applicable to concrete mixers having a rated capacity greater than or equal to 70/50.

### 2 Normative references

The following referenced documents are indispensable for the application of this document. For dated references, only the edition cited applies. For undated references, the latest edition of the referenced document (including any amendments) applies.

ISO 1920-1, *Testing of concrete — Part 1: Sampling of fresh concrete*

ISO 1920-2, *Testing of concrete — Part 2: Properties of fresh concrete*

ISO 1920-3, *Testing of concrete — Part 3: Making and curing test specimens*

ISO 1920-4, *Testing of concrete — Part 4: Strength of hardened concrete*

ISO 3310-1, *Test sieves — Technical requirements and testing — Part 1: Test sieves of metal wire cloth*

ISO 6783, *Coarse aggregates for concrete — Determination of particle density and water absorption — Hydrostatic balance method*

ISO 7033, *Fine and coarse aggregates for concrete — Determination of the particle mass-per-volume and water absorption — Pycnometer method*

ISO 11375, *Building construction machinery and equipment — Terms and definitions*

ISO 18650-1, *Building construction machinery and equipment — Concrete mixers — Part 1: Vocabulary and general specifications*

### 3 Terms and definitions

For the purposes of this document, the terms and definitions given in ISO 18650-1 and ISO 11375 apply.

### 4 Requirements for mixer verified

The design and execution of the whole structure of the mixer and its components, such as the mixing chamber (drum, pan, or trough), rotor with blades or paddle agitator(s), their directions of rotation, charging and discharging devices (if any), should be verified according to the manufacturer's instructions.

It shall be determined that the number of revolutions per minute of a drum or mixing tools conforms to the manufacturer's specification.

The drive system should be able to restart 5 min after being stopped when the mixer has completed the mixing of the test batch as specified in 5.2.

NOTE 1 The “restart” is for the additional mixing and does not warrant a series of restarts for the next batches.

The mixer shall be discharged according to its design or as specified by the manufacturer. The closure of the mixing chamber shall be so designed that the loss of the mix before discharge, i.e. during charging and mixing, remains below 0,5 %.

NOTE 2 The “below 0,5%” does not apply to the 1st batch which has more adhesion of mortar to the inner wall of drum.

## 5 Mixing performance test

### 5.1 General

The mixing efficiency is determined by the uniformity of the concrete mix and the compressive strength of the concrete cubes or cylinders, sampled after mixing time. The determination of the uniformity of the concrete mix includes the following variance tests on the sampled specimens:

- a) air content;
- b) content of mortar per unit volume;
- c) content of coarse aggregate per unit volume;
- d) consistency (slump).

iTech STANDARD PREVIEW  
(standards.itech.ai)

The values of the concrete-mix component content (air, mortar, coarse aggregate), determined as the test results, as well as the consistency and compressive strength, are subsequently used for calculation of their variances.

<https://standards.itech.ai/catalog/standards/sist/c8d34fa-3167-4e7f-86b4-ffbf351c6d88/iso-18650-2-2014>

For calculating the variance, ΔX, of the considered components' content and other features, expressed as a percentage, the following formula is applied:

$$\Delta X = \frac{X_1 - X_2}{X_1 + X_2} \times 100$$

where

X<sub>1</sub> is the value of component content, slump and compressive strength received from portion 1 or 2 — larger value of X<sub>1</sub> and X<sub>2</sub>;

X<sub>2</sub> is the value of component content, slump and compressive strength received from portion 1 or 2 — smaller value of X<sub>1</sub> and X<sub>2</sub>.

To explain the physical sense of this formula, it can be transformed as follows:

$$\Delta X = \frac{X_1 - X_2}{X_1 + X_2} = \frac{\frac{X_1 + X_2}{2} - X_2}{\frac{X_1 + X_2}{2}}$$

In this form it represents the variance of a subject parameter in two portions against its average value.

For evaluation of the test results, the particular variance values are compared with the acceptable results according to Clause 6.



## 5.2 Concrete mix preparation

The test concrete to be used for the mixing performance test should be specified by the concrete manufacturer or testing laboratory with the following conditions: coarse aggregates up to 20 mm or 25 mm, slump (80 ± 30) mm, air content (4,5 ± 1,5) % and nominal compressive strength (25 ± 5) N/mm<sup>2</sup>. In case of difficulty in obtaining of the assumed air content, an appropriate admixture may be used.

The quantity of components usually corresponds to the rating capacity declared by the mixer's manufacturer.

The constituent materials are to be weighed with measuring uncertainty limits of ± 3 %.

The sequence of a mixer charging with particular components should be as specified in the manufacturer's instruction. If there is no such instruction, the method of charging should be noted in the test report.

The charging of a mixer with constituent materials shall be carried out with a minimum loss of materials.

The mixing time shall be as specified by the manufacturer. If no such specification is available, the following approximate values — depending on the mixer type and its capacity — are recommended:

- a) For batch-type gravity mixers:
  - rated capacity 1,0 m<sup>3</sup> and less, 60 s;
  - rated capacity above 1,0 m<sup>3</sup>, 5 s added to 60 s for every 0,5 m<sup>3</sup> increase.
- b) For batch-type compulsory mixers:
  - rated capacity 3,0 m<sup>3</sup> and less, 30 s;
  - rated capacity above 3,0 m<sup>3</sup>, 15 s added to 30 s for every 1,5 m<sup>3</sup> increase.
- c) For continuous mixers: a mixing time corresponding to the duration of the concrete mix in the mixing chamber, which shall be at least 10 s.

## 5.3 Sampling

### 5.3.1 General

Two portions of the concrete mix are sampled directly from the mixing chamber immediately after ensured mixing time (see [Figures 2, 3, 4 and 5](#)). Where the direct sampling from inside the mixing chamber is difficult, the sampling may be done from the concrete mix discharged to the hopper (see [Figures 6 and 7](#)). The volume of the sample (portion) should be a minimum of 20 l for batch mixers and 100 l for continuous mixers (see [5.3.4](#)). Afterwards, the specimens for particular variance tests are prepared.

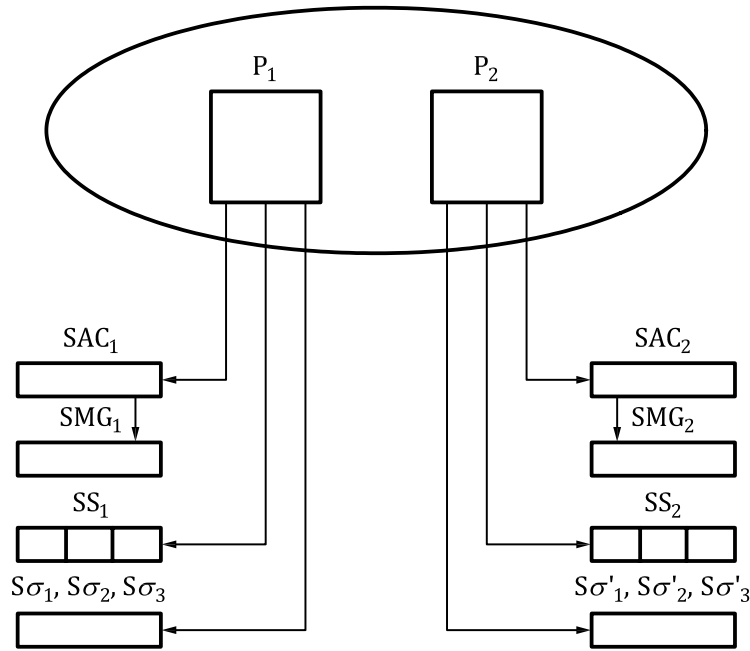

**Key**

- P<sub>1</sub>, P<sub>2</sub> concrete mix portion sampled from the mixer
- SAC<sub>1</sub>, SAC<sub>2</sub> specimens for air content test
- SMG<sub>1</sub>, SMG<sub>2</sub> specimens for air content test used for coarse aggregate and mortar content testing in further sequence
- Sσ<sub>1</sub>, Sσ<sub>2</sub>, Sσ<sub>3</sub> specimens for compressive strength test (three cubes or cylinders from each portion)
- Sσ'<sub>1</sub>, Sσ'<sub>2</sub>, Sσ'<sub>3</sub> specimens for consistency (slump) test
- SS<sub>1</sub>, SS<sub>2</sub> specimens for consistency (slump) test

ISO 18650-2:2014  
<https://standards.iteh.ai/catalog/standards/sist/c8d34fa-3167-4e7f-86b4-ffb351c6d88/iso-18650-2-2014>

**Figure 1 — General scheme of sampling**

**5.3.2 Batch-type compulsory mixers**

**5.3.2.1 Pan-type mixers**

In pan-type mixers the samples (portions) are taken from concentric circles. [Figure 2](#) shows an example of sampling in a turbo mixer.

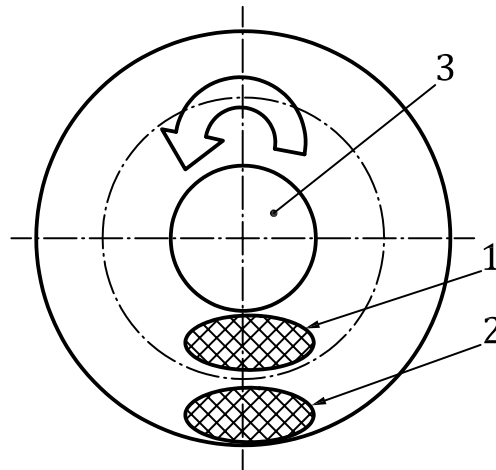
**Key**

- 1 centre portion
- 2 edge portion
- 3 centre cylinder covering dead mixing area

**Figure 2 — Sampling in turbo mixer**

In other types of pan-type mixers, those not having a centre cylinder covering the dead mixing area, the radius separating two concentric circles is equal to a quarter of the inner pan diameter.

(standards.iteh.ai)

**5.3.2.2 Paddle mixers**

Examples of sampling in paddles mixers with one or two paddle agitators are shown in the [Figure 3](#).

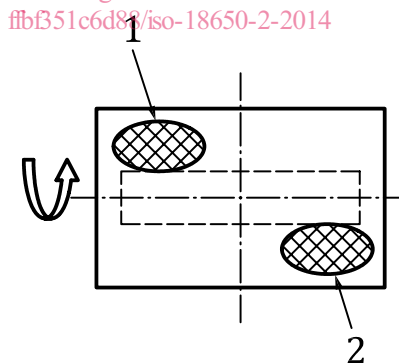
**a) One-agitator mixer**