



SLOVENSKI STANDARD

SIST EN 13523-11:2019

01-november-2019

Nadomešča:

SIST EN 13523-11:2011

Prevljučene kovine, ki se navijajo - Preskusne metode - 11. del: Odpornost proti topilom (preskus z drgnjenjem)

Coil coated metals - Test methods - Part 11: Resistance to solvents (rubbing test)

Bandbeschichtete Metalle - Prüfverfahren - Teil 11: Beständigkeit gegen Lösemittel (Reibtest)

iTeh STANDARD PREVIEW

(standards.iteh.ai)

Tôles prélaquées - Méthodes d'essai - Partie 11 : Résistance aux solvants (essai de frottement)

[SIST EN 13523-11:2019](https://standards.iteh.ai/catalog/standards/sist/310f8c93-b1f8-4f88-9b56-9dfbb730b2fb/sist-en-13523-11-2019)

[https://standards.iteh.ai/catalog/standards/sist/310f8c93-b1f8-4f88-9b56-](https://standards.iteh.ai/catalog/standards/sist/310f8c93-b1f8-4f88-9b56-9dfbb730b2fb/sist-en-13523-11-2019)

[9dfbb730b2fb/sist-en-13523-11-2019](https://standards.iteh.ai/catalog/standards/sist/310f8c93-b1f8-4f88-9b56-9dfbb730b2fb/sist-en-13523-11-2019)

Ta slovenski standard je istoveten z: EN 13523-11:2019

ICS:

25.220.60

Organske prevleke

Organic coatings

SIST EN 13523-11:2019

en,fr,de

iTeh STANDARD PREVIEW
(standards.iteh.ai)

[SIST EN 13523-11:2019](#)

<https://standards.iteh.ai/catalog/standards/sist/310f8c93-b1f8-4f88-9b56-9dfbb730b2fb/sist-en-13523-11-2019>

EUROPEAN STANDARD
NORME EUROPÉENNE
EUROPÄISCHE NORM

EN 13523-11

September 2019

ICS 25.220.60

Supersedes EN 13523-11:2011

English Version

Coil coated metals - Test methods - Part 11: Resistance to solvents (rubbing test)

Tôles prélaquées - Méthodes d'essai - Partie 11 :
Résistance aux solvants (essai de frottement)

Bandbeschichtete Metalle - Prüfverfahren - Teil 11:
Beständigkeit gegen Lösemittel (Reibtest)

This European Standard was approved by CEN on 1 July 2019.

CEN members are bound to comply with the CEN/CENELEC Internal Regulations which stipulate the conditions for giving this European Standard the status of a national standard without any alteration. Up-to-date lists and bibliographical references concerning such national standards may be obtained on application to the CEN-CENELEC Management Centre or to any CEN member.

This European Standard exists in three official versions (English, French, German). A version in any other language made by translation under the responsibility of a CEN member into its own language and notified to the CEN-CENELEC Management Centre has the same status as the official versions.

CEN members are the national standards bodies of Austria, Belgium, Bulgaria, Croatia, Cyprus, Czech Republic, Denmark, Estonia, Finland, France, Germany, Greece, Hungary, Iceland, Ireland, Italy, Latvia, Lithuania, Luxembourg, Malta, Netherlands, Norway, Poland, Portugal, Republic of North Macedonia, Romania, Serbia, Slovakia, Slovenia, Spain, Sweden, Switzerland, Turkey and United Kingdom.

<https://standards.iteh.ai/catalog/standards/sist/310f8c93-b1f8-4f88-9b56-9dfbb730b2fb/sist-en-13523-11-2019>



EUROPEAN COMMITTEE FOR STANDARDIZATION
COMITÉ EUROPÉEN DE NORMALISATION
EUROPÄISCHES KOMITEE FÜR NORMUNG

CEN-CENELEC Management Centre: Rue de la Science 23, B-1040 Brussels

Contents		Page
European foreword		3
1	Scope	5
2	Normative references	5
3	Terms and definitions	5
4	Principle	5
5	Material	5
6	Apparatus	6
7	Sampling	6
8	Test panels	6
9	Test conditions	6
10	Procedure	7
11	Expression of results	7
12	Precision	7
13	Test report	7
Bibliography		8

[SIST EN 13523-11:2019](https://standards.iteh.ai/catalog/standards/sist/310f8c93-b1f8-4f88-9b56-9dfbb730b2fb/sist-en-13523-11-2019)
<https://standards.iteh.ai/catalog/standards/sist/310f8c93-b1f8-4f88-9b56-9dfbb730b2fb/sist-en-13523-11-2019>

European foreword

This document (EN 13523-11:2019) has been prepared by Technical Committee CEN/TC 139 “Paints and varnishes”, the secretariat of which is held by DIN.

This European Standard shall be given the status of a national standard, either by publication of an identical text or by endorsement, at the latest by March 2020, and conflicting national standards shall be withdrawn at the latest by March 2020.

Attention is drawn to the possibility that some of the elements of this document may be the subject of patent rights. CEN shall not be held responsible for identifying any or all such patent rights.

This document supersedes EN 13523-11:2011.

The main changes compared to EN 13523-11:2011 are:

- a) the absorbent material is described in more detail: e.g. synthetic material shall not be used;
- b) other solvents such as acetone and methyl isobutyl ketone are also allowed;
- c) the description of the test panel is given in more details;
- d) it is stated that the solvent used shall be also at room temperature before use;
- e) it is amended that visual inspection of the rubbed area shall be carried out during the test and immediately after the rubbing operation;
- f) “strokes” are changed to “rubs”;
- g) a figure of the test apparatus is added;
- h) items c), f) and i) have been added to the test report (Clause 13);
- i) the text has been editorially revised and the normative references have been updated.

The EN 13523 series, *Coil coated metals — Test methods*, consists of the following parts:

- *Part 0: General introduction*
- *Part 1: Film thickness*
- *Part 2: Gloss*
- *Part 3: Colour difference — Instrumental comparison*
- *Part 4: Pencil hardness*
- *Part 5: Resistance to rapid deformation (impact test)*
- *Part 6: Adhesion after indentation (cupping test)*
- *Part 7: Resistance to cracking on bending (T-bend test)*

EN 13523-11:2019 (E)

- *Part 8: Resistance to salt spray (fog)*
- *Part 9: Resistance to water immersion*
- *Part 10: Resistance to fluorescent UV radiation and water condensation*
- *Part 11: Resistance to solvents (rubbing test)*
- *Part 12: Resistance to scratching*
- *Part 13: Resistance to accelerated ageing by the use of heat*
- *Part 14: Chalking (Helmen method)*
- *Part 15: Metamerism*
- *Part 16: Resistance to abrasion*
- *Part 17: Adhesion of strippable films*
- *Part 18: Resistance to staining*
- *Part 19: Panel design and method of atmospheric exposure testing*
- *Part 20: Foam adhesion*
- *Part 21: Evaluation of outdoor exposed panels*
- *Part 22: Colour difference — Visual comparison*
- *Part 23: Resistance to humid atmospheres containing sulfur dioxide*
- *Part 24: Resistance to blocking and pressure marking*
- *Part 25: Resistance to humidity*
- *Part 26: Resistance to condensation of water*
- *Part 27: Resistance to humid poultice (Cataplasm test)*
- *Part 29: Resistance to environmental soiling (Dirt pick-up and striping)*

ITeH STANDARD PREVIEW
(standards.iteh.ai)

SIST EN 13523-11:2019
<https://standards.iteh.ai/catalog/standards/sist/310f8c93-b1f8-4f88-9b56-9dfbb730b2fb/sist-en-13523-11-2019>

According to the CEN-CENELEC Internal Regulations, the national standards organisations of the following countries are bound to implement this European Standard: Austria, Belgium, Bulgaria, Croatia, Cyprus, Czech Republic, Denmark, Estonia, Finland, France, Germany, Greece, Hungary, Iceland, Ireland, Italy, Latvia, Lithuania, Luxembourg, Malta, Netherlands, Norway, Poland, Portugal, Republic of North Macedonia, Romania, Serbia, Slovakia, Slovenia, Spain, Sweden, Switzerland, Turkey and the United Kingdom.

1 Scope

This part of the EN 13523 series specifies the procedure for evaluating the degree of curing by assessing the resistance of a cured organic coating film, applied on a metallic substrate, to a specified organic solvent.

2 Normative references

The following documents are referred to in the text in such a way that some or all of their content constitutes requirements of this document. For dated references, only the edition cited applies. For undated references, the latest edition of the referenced document (including any amendments) applies.

EN 13523-0:2014, *Coil coated metals — Test methods — Part 0: General introduction*

EN 23270, *Paints and varnishes and their raw materials — Temperatures and humidities for conditioning and testing (ISO 3270)*

3 Terms and definitions

For the purposes of this document, the terms and definitions given in EN 13523-0 apply.

ISO and IEC maintain terminological databases for use in standardization at the following addresses:

- IEC Electropedia: available at <http://www.electropedia.org/>
- ISO Online browsing platform: available at <http://www.iso.org/obp>

(standards.iteh.ai)

4 Principle

The surface of the organic coating is rubbed with an absorbent material soaked in a specified organic solvent at a specified load. The rubbing is carried out in parallel with the rolling direction. The rubs are counted as a double rub, i.e. one rub forward and one rub backward constitute a double rub.

5 Material

5.1 Absorbent material

Cotton wool of sufficient quantity to stay wet for the duration of the test and to prevent contact between the test panel and the artificial finger used under the conditions of the test.

Other materials such as textile or felt pads may be used but will give different results. If another material than cotton wool is used, this shall be stated in the test report. Synthetic materials shall not be used.

Materials with a hard surface shall not be used.

5.2 Solvent

Butanone (methyl ethyl ketone, MEK, CAS-No 78-93-3) shall be used if not otherwise specified.

Other similar organic solvents might be used upon agreement, such as Acetone (CAS-No 67-64-1), Methyl-Isobutyl-Ketone (MiBK, CAS-No 108-10-1).

The solvent used shall be stated in the test report.

EN 13523-11:2019 (E)

6 Apparatus

6.1 An automated or mechanical test device with artificial finger with a circular contact area between 100 mm² and 200 mm² of contact surface, capable of making longitudinal back and forth rubs (double rubs) under a constant pressure of (0,05 ± 0,01) MPa. The length of the rubs shall be at least 75 mm. Figure 1 illustrates the principle of a mechanical test device.

NOTE For example, for a pressure of 0,05 MPa and a contact area of 100 mm², a dead weight rubbing block of 0,5 kg is required.

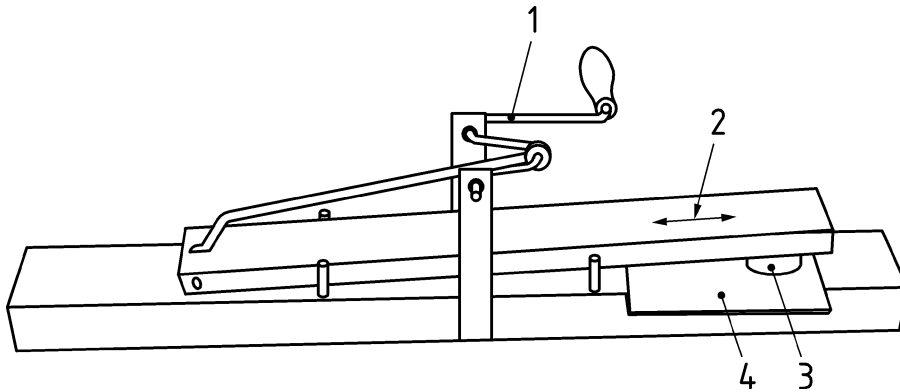

Key

- 1 crank mechanism (crank handle)
- 2 direction of rub motion
- 3 abrasion tool with the absorbent material
- 4 test specimen

STANDARD PREVIEW
(standards.iteh.ai)

SIST EN 13523-11:2019

<https://standards.iteh.ai/catalog/standards/sist/310f8c93-b1f8-4f88-9b56-9dfbb730b2fb/sist-en-13523-11-2019>

Figure 1 — Crockmeter (example with manual crank mechanism)

7 Sampling

Shall be in accordance with EN 13523-0.

8 Test panels

Shall be in accordance with EN 13523-0.

The test panel shall be of sufficient size that the area wetted during the test is at least 20 mm from the edges. The length edge of at least 75 mm shall be parallel to the rolling direction. The surface of the test panel shall be clean and free from any loose material and particles.

9 Test conditions

Coatings shall not be tested until they have cooled down to ambient temperature. The solvent used shall be also at room temperature before use. In case of dispute, the temperature shall be (23 ± 2) °C and the relative humidity shall be (50 ± 5) %, in accordance with EN 23270. Conditioning is carried out in accordance with EN 13523-0:2014, Clause 6.

10 Procedure

Cover the whole surface area of the artificial finger (6.1) with absorbent material (5.1). Saturate the absorbent material with the solvent (5.2) and maintain an excess of the liquid on the test surface. Place the tip of the artificial finger on the test panel avoiding contact with the edges. Start the movement for the specified number of rubs. The rubbing speed shall be approximately 1 s per double rub and the movement shall be continuous.

The absorbent material shall remain wet for the duration of the test.

After the specified number of rubs, the test panel shall be evaluated to verify whether or not the organic coating under test has been removed and the material underneath can be seen. Avoid any abrasive contamination that will score the panel surface and invalidate the result of the test.

Visual inspection of the rubbed area shall be carried out during the test and immediately after the rubbing operation. The evaluation shall disregard the contact area on both extremes of the tested surface.

NOTE The judgement of the test result can depend upon the experience of the operator.

11 Expression of results

The result shall be expressed as a pass or fail at the specified number of double rubs.

12 Precision

No precision data are available.

iTeh STANDARD PREVIEW
(standards.iteh.ai)

13 Test report

The test report shall contain at least the following information:

- a) all details necessary to identify the product tested;
- b) a reference to this part of the EN 13523 series (EN 13523-11);
- c) the type and producer of the absorbent material;
- d) the number of double rubs;
- e) the solvent used;
- f) whether the material underneath is the substrate or the next paint layer;
- g) the result of the visual examination of the rub area and the absorbent material, for indication of coating removal;
- h) any deviation from the test method specified;
- i) any unusual observation (deviation) during testing;
- j) the date of the test.