

ETSI TS 129 551 V15.12.0 (2022-07)



**5G;  
5G System;  
Packet Flow Description Management Service;  
Stage 3  
(3GPP TS 29.551 version 15.12.0 Release 15)**

<https://standards.iteh.ai/catalog/standards/sist/53a71f8a-7a09-42a6-942a-035c567ca919/etsi-ts-129-551-v15-12-0-2022-07>



---

**Reference**

RTS/TSGC-0329551 vfc0

---

**Keywords**

5G

**ETSI**

650 Route des Lucioles  
F-06921 Sophia Antipolis Cedex - FRANCE

---

Tel.: +33 4 92 94 42 00 Fax: +33 4 93 65 47 16

Siret N° 348 623 562 00017 - APE 7112B  
Association à but non lucratif enregistrée à la  
Sous-Préfecture de Grasse (06) N° w061004871

---

**Important notice**

---

The present document can be downloaded from:

<http://www.etsi.org/standards-search>

The present document may be made available in electronic versions and/or in print. The content of any electronic and/or print versions of the present document shall not be modified without the prior written authorization of ETSI. In case of any existing or perceived difference in contents between such versions and/or in print, the prevailing version of an ETSI deliverable is the one made publicly available in PDF format at [www.etsi.org/deliver](http://www.etsi.org/deliver).

Users of the present document should be aware that the document may be subject to revision or change of status.

Information on the current status of this and other ETSI documents is available at

<https://portal.etsi.org/TB/ETSIDeliverableStatus.aspx>

If you find errors in the present document, please send your comment to one of the following services:

<https://standards-portal.etsi.org/standards-portal> <https://portal.etsi.org/People/CommitteeSupportStaff.aspx> 42a6-942a-

If you find a security vulnerability in the present document, please report it through our

Coordinated Vulnerability Disclosure Program:

<https://www.etsi.org/standards/coordinated-vulnerability-disclosure>

---

**Notice of disclaimer & limitation of liability**

---

The information provided in the present deliverable is directed solely to professionals who have the appropriate degree of experience to understand and interpret its content in accordance with generally accepted engineering or other professional standard and applicable regulations.

No recommendation as to products and services or vendors is made or should be implied.

No representation or warranty is made that this deliverable is technically accurate or sufficient or conforms to any law and/or governmental rule and/or regulation and further, no representation or warranty is made of merchantability or fitness for any particular purpose or against infringement of intellectual property rights.

In no event shall ETSI be held liable for loss of profits or any other incidental or consequential damages.

Any software contained in this deliverable is provided "AS IS" with no warranties, express or implied, including but not limited to, the warranties of merchantability, fitness for a particular purpose and non-infringement of intellectual property rights and ETSI shall not be held liable in any event for any damages whatsoever (including, without limitation, damages for loss of profits, business interruption, loss of information, or any other pecuniary loss) arising out of or related to the use of or inability to use the software.

---

**Copyright Notification**

---

No part may be reproduced or utilized in any form or by any means, electronic or mechanical, including photocopying and microfilm except as authorized by written permission of ETSI.

The content of the PDF version shall not be modified without the written authorization of ETSI.

The copyright and the foregoing restriction extend to reproduction in all media.

© ETSI 2022.

All rights reserved.

---

# Intellectual Property Rights

## Essential patents

IPRs essential or potentially essential to normative deliverables may have been declared to ETSI. The declarations pertaining to these essential IPRs, if any, are publicly available for **ETSI members and non-members**, and can be found in ETSI SR 000 314: "*Intellectual Property Rights (IPRs); Essential, or potentially Essential, IPRs notified to ETSI in respect of ETSI standards*", which is available from the ETSI Secretariat. Latest updates are available on the ETSI Web server (<https://ipr.etsi.org/>).

Pursuant to the ETSI Directives including the ETSI IPR Policy, no investigation regarding the essentiality of IPRs, including IPR searches, has been carried out by ETSI. No guarantee can be given as to the existence of other IPRs not referenced in ETSI SR 000 314 (or the updates on the ETSI Web server) which are, or may be, or may become, essential to the present document.

## Trademarks

The present document may include trademarks and/or tradenames which are asserted and/or registered by their owners. ETSI claims no ownership of these except for any which are indicated as being the property of ETSI, and conveys no right to use or reproduce any trademark and/or tradename. Mention of those trademarks in the present document does not constitute an endorsement by ETSI of products, services or organizations associated with those trademarks.

**DECT™**, **PLUGTESTS™**, **UMTS™** and the ETSI logo are trademarks of ETSI registered for the benefit of its Members. **3GPP™** and **LTE™** are trademarks of ETSI registered for the benefit of its Members and of the 3GPP Organizational Partners. **oneM2M™** logo is a trademark of ETSI registered for the benefit of its Members and of the oneM2M Partners. **GSM®** and the GSM logo are trademarks registered and owned by the GSM Association.

---

# Legal Notice

This Technical Specification (TS) has been produced by ETSI 3rd Generation Partnership Project (3GPP).

The present document may refer to technical specifications or reports using their 3GPP identities. These shall be interpreted as being references to the corresponding ETSI deliverables.

The cross reference between 3GPP and ETSI identities can be found under <http://webapp.etsi.org/key/queryform.asp>.

---

# Modal verbs terminology

In the present document "**shall**", "**shall not**", "**should**", "**should not**", "**may**", "**need not**", "**will**", "**will not**", "**can**" and "**cannot**" are to be interpreted as described in clause 3.2 of the [ETSI Drafting Rules](#) (Verbal forms for the expression of provisions).

"**must**" and "**must not**" are **NOT** allowed in ETSI deliverables except when used in direct citation.

# Contents

Intellectual Property Rights .....	2
Legal Notice .....	2
Modal verbs terminology.....	2
Foreword.....	5
1 Scope .....	6
2 References .....	6
3 Definitions, symbols and abbreviations .....	7
3.1 Definitions .....	7
3.2 Abbreviations .....	7
4 Packet Flow Description Management Service.....	7
4.1 Service Description .....	7
4.1.1 Overview .....	7
4.1.2 Service Architecture .....	7
4.1.3 Network Functions.....	8
4.1.3.1 Packet Flow Description Function (PFD) .....	8
4.1.3.2 NF Service Consumers.....	8
4.2 Service Operations .....	8
4.2.1 Introduction.....	8
4.2.2 Nnef_PFDmanagement_Fetch Service Operation .....	9
4.2.2.1 General .....	9
4.2.2.2 Retrieval of PFDs.....	9
4.2.3 Nnef_PFDmanagement_Subscribe Service Operation .....	10
4.2.3.1 General .....	10
4.2.3.2 Subscription for event notifications on PFDs change .....	10
4.2.4 Nnef_PFDmanagement_Notify Service Operation.....	11
4.2.4.1 General .....	11
4.2.4.2 Notification of PFD change.....	11
4.2.5 Nnef_PFDmanagement_Unsubscribe Service Operation .....	12
4.2.5.1 General .....	12
4.2.5.2 Unsubscribe from event notifications on PFDs change.....	12
5 Nnef_PFDmanagement API.....	12
5.1 Introduction .....	12
5.2 Usage of HTTP.....	13
5.2.1 General.....	13
5.2.2 HTTP standard headers.....	13
5.2.2.1 General .....	13
5.2.2.2 Content type .....	13
5.2.3 HTTP custom headers.....	13
5.3 Resources .....	14
5.3.1 Resource Structure.....	14
5.3.2 Resource: PFD of applications.....	14
5.3.2.1 Description .....	14
5.3.2.2 Resource definition .....	15
5.3.2.3 Resource Standard Methods.....	15
5.3.2.3.1 GET .....	15
5.3.2.4 Resource Custom Operations .....	15
5.3.3 Resource: Individual application PFD .....	15
5.3.3.1 Description .....	15
5.3.3.2 Resource definition .....	15
5.3.3.3 Resource Standard Methods.....	16
5.3.3.3.1 GET .....	16
5.3.3.4 Resource Custom Operations .....	16
5.3.4 Resource: PFD subscriptions .....	16

5.3.4.1	Description .....	16
5.3.4.2	Resource definition .....	16
5.3.4.3	Resource Standard Methods.....	17
5.3.4.3.1	POST .....	17
5.3.4.4	Resource Custom Operations .....	17
5.3.5	Resource: Individual PFD subscription .....	17
5.3.5.1	Description .....	17
5.3.5.2	Resource definition .....	17
5.3.5.3	Resource Standard Methods.....	17
5.3.5.3.1	DELETE.....	17
5.3.5.4	Resource Custom Operations .....	18
5.4	Custom Operations without associated resources.....	18
5.5	Notifications .....	18
5.5.1	General.....	18
5.5.2	PFD Change Notification.....	18
5.5.2.1	Description .....	18
5.5.2.2	Target URI .....	18
5.5.2.3	Standard Methods .....	19
5.5.2.3.1	POST .....	19
5.6	Data Model.....	19
5.6.1	General.....	19
5.6.2	Structured data types.....	20
5.6.2.1	Introduction.....	20
5.6.2.2	Type: PfdDataForApp.....	20
5.6.2.3	Type: PfdSubscription.....	21
5.6.2.4	Type: PfdChangeNotification .....	21
5.6.2.5	Type: PfdContent .....	22
5.6.2.6	Type: PfdChangeReport.....	22
5.6.3	Simple data types and enumerations.....	22
5.6.3.1	Introduction.....	22
5.6.3.2	Simple data types .....	22
5.7	Error handling .....	23
5.7.1	General.....	23
5.7.2	Protocol Errors.....	23
5.7.3	Application Errors .....	23
5.8	Feature negotiation.....	23
5.9	Security .....	23
<b>Annex A (normative):    OpenAPI specification.....</b>		<b>25</b>
A.1	General .....	25
A.2	Nnef_PFDmanagement API.....	25
<b>Annex B (informative):    Change history .....</b>		<b>31</b>
History .....		32

---

# Foreword

This Technical Specification has been produced by the 3rd Generation Partnership Project (3GPP).

The contents of the present document are subject to continuing work within the TSG and may change following formal TSG approval. Should the TSG modify the contents of the present document, it will be re-released by the TSG with an identifying change of release date and an increase in version number as follows:

Version x.y.z

where:

- x the first digit:
  - 1 presented to TSG for information;
  - 2 presented to TSG for approval;
  - 3 or greater indicates TSG approved document under change control.
- y the second digit is incremented for all changes of substance, i.e. technical enhancements, corrections, updates, etc.
- z the third digit is incremented when editorial only changes have been incorporated in the document.

iTeh STANDARD PREVIEW  
(standards.iteh.ai)

[ETSI TS 129 551 V15.12.0 \(2022-07\)](https://standards.iteh.ai/catalog/standards/sist/53a71f8a-7a09-42a6-942a-035c567ca919/etsi-ts-129-551-v15-12-0-2022-07)

<https://standards.iteh.ai/catalog/standards/sist/53a71f8a-7a09-42a6-942a-035c567ca919/etsi-ts-129-551-v15-12-0-2022-07>

---

# 1 Scope

The present document provides the stage 3 specification of the PFD Management Service of 5G system.

The stage 2 definition and related procedures of the PFD Management Service are contained in 3GPP TS 23.502 [3] and 3GPP TS 23.503 [4]. The 5G System Architecture is defined in 3GPP TS 23.501 [2].

The Technical Realization of the Service Based Architecture and the Principles and Guidelines for Services Definition of the 5G System are specified in 3GPP TS 29.500 [5] and 3GPP TS 29.501 [6].

The Packet Flow Description Function (PFDF) provides the PFD Management Service to the NF consumers (i.e. Session Management Function). The PFDF is functionality within the NEF.

---

# 2 References

The following documents contain provisions which, through reference in this text, constitute provisions of the present document.

- References are either specific (identified by date of publication, edition number, version number, etc.) or non-specific.
- For a specific reference, subsequent revisions do not apply.
- For a non-specific reference, the latest version applies. In the case of a reference to a 3GPP document (including a GSM document), a non-specific reference implicitly refers to the latest version of that document *in the same Release as the present document*.

- [1] 3GPP TR 21.905: "Vocabulary for 3GPP Specifications".
- [2] 3GPP TS 23.501: "System Architecture for the 5G System; Stage 2".
- [3] 3GPP TS 23.502: "Procedures for the 5G System; Stage 2".
- [4] 3GPP TS 23.503: "Policy and Charging Control Framework for the 5G System; Stage 2".
- [5] 3GPP TS 29.500: "5G System; Technical Realization of Service Based Architecture; Stage 3".
- [6] 3GPP TS 29.501: "5G System; Principles and Guidelines for Services Definition; Stage 3".
- [7] IETF RFC 7540: "Hypertext Transfer Protocol Version 2 (HTTP/2)".
- [8] IETF RFC 8259: "The JavaScript Object Notation (JSON) Data Interchange Format".
- [9] OpenAPI: "OpenAPI 3.0.0 Specification", <https://github.com/OAI/OpenAPI-Specification/blob/master/versions/3.0.0.md>.
- [10] 3GPP TS 29.571: "5G System; Common Data Types for Service Based Interfaces Stage 3".
- [11] 3GPP TS 29.122: "T8 reference point for Northbound APIs".
- [12] 3GPP TS 29.251: "Gw and Gwn reference points for sponsored data connectivity".
- [13] 3GPP TS 29.510: "5G System; Network Function Repository Services; Stage 3".
- [14] 3GPP TS 33.501: "Security architecture and procedures for 5G system".
- [15] IETF RFC 6749: "The OAuth 2.0 Authorization Framework".
- [16] IETF RFC 7807: "Problem Details for HTTP APIs".
- [17] 3GPP TR 21.900: "Technical Specification Group working methods".
- [18] IETF RFC 6733: "Diameter Base Protocol".

---

## 3 Definitions, symbols and abbreviations

### 3.1 Definitions

For the purposes of the present document, the terms and definitions given in 3GPP TR 21.905 [1] and the following apply. A term defined in the present document takes precedence over the definition of the same term, if any, in 3GPP TR 21.905 [1].

### 3.2 Abbreviations

For the purposes of the present document, the abbreviations given in 3GPP TR 21.905 [1] and the following apply. An abbreviation defined in the present document takes precedence over the definition of the same abbreviation, if any, in 3GPP TR 21.905 [1].

JSON	JavaScript Object Notation
NEF	Network Exposure Function
NRF	Network Repository Function
PFD	Packet Flow Description
PFDF	Packet Flow Description Function
SBI	Service Based Interface
SMF	Session Management Function

---

## 4 Packet Flow Description Management Service

### 4.1 Service Description

#### 4.1.1 Overview

The PFD Management Service, as defined as defined in 3GPP TS 23.501 [2], 3GPP TS 23.502 [3] and 3GPP TS 23.503 [4], is provided by the Packet Flow Description Function (PFDF).

The only known NF Service Consumer is the SMF.

This service:

- allows an SMF to subscribe to and unsubscribe from PFD changes;
- notifies an SMF about the changed PFDs; and
- allows an SMF to retrieve PFDs.

#### 4.1.2 Service Architecture

The 5G System Architecture is defined in 3GPP TS 23.501 [2]. The Policy and Charging related 5G architecture is also described in 3GPP TS 23.503 [4].

The PFD Management Service is provided by the PFDF to the SMF and shown in the SBI representation model in Figure 4.1.2-1. PFDF is functionality within NEF.

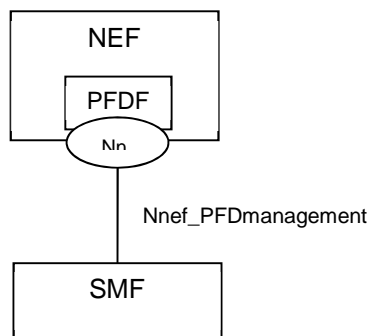

Figure 4.1.2-1: Reference Architecture for the Nnef\_PFDmanagement Service; SBI representation



Figure 4.1.2-2: Reference Architecture for the Nnef\_PFDmanagement Service; reference point representation

## 4.1.3 Network Functions

### 4.1.3.1 Packet Flow Description Function (PFDF)

The Packet Flow Description Function (PFDF):

- provides PFDs associated with one or more Application Identifiers; and
- allows NF consumers to subscribe to and unsubscribe from the notification of changes of PFDs for Application Identifier.

### 4.1.3.2 NF Service Consumers

The SMF shall support:

- requesting and receiving the PFD(s) for one or more Application Identifiers.

## 4.2 Service Operations

### 4.2.1 Introduction

Service operations defined for the Nnef\_PFDmanagement Service are shown in table 4.2.1-1.

**Table 4.2.1-1: Nnef\_PFDmanagement Service Operations**

Service Operation Name	Description	Initiated by
Nnef_PFDmanagement_Fetch	Provides the PFDs for application identifier(s) to the NF service consumer.	SMF
Nnef_PFDmanagement_Subscribe	Allows NF service consumers to subscribe the notification of events when the PFDs for application identifier change.	SMF
Nnef_PFDmanagement_Notify	Notifies NF service consumer to update and/or delete the PFDs for application identifier(s).	PFDF
Nnef_PFDmanagement_Unsubscribe	Allows NF service consumers to unsubscribe the notification of events.	SMF

## 4.2.2 Nnef\_PFDmanagement\_Fetch Service Operation

### 4.2.2.1 General

The Nnef\_PFDmanagement\_Fetch service operation provides a means for the NF service consumer to retrieve the PFDs for one or more application identifier(s).

The following procedures using the Nnef\_PFDmanagement\_Fetch service operation are supported:

- Retrieval of PFDs.

### 4.2.2.2 Retrieval of PFDs

This procedure as shown in Figure 4.2.2.2-1 is used to retrieve PFDs for an application identifier from the PFDF. This procedure enables the NF service consumer to retrieve PFDs for an Application Identifier(s) from the PFDF when:

- a PCC rule with this application identifier is provided/activated by the PCF and the PFDs provided by the PFDF are not available at the NF service consumer; or
- the caching timer for an application identifier elapses and a PCC rule for this application identifier is still active.

When the SMF removes the last PCC rule that refers to the corresponding application identifier, or when the caching timer expires and no PCC rule refers to the application identifier, the SMF may remove the PFD(s) related with the application identifier.

The PFDs retrieved from PFDF take precedence over any PFDs pre-configured in the SMF. If all PFDs retrieved from the PFDF are removed for an application identifier, the pre-configured PFDs shall be applied again for the application identifier.

The PFDF may provide caching time value together with the PFDs for an application identifier. The caching time value retrieved from the PFDF takes precedence over the default caching time value configured in the NF service consumer. If no caching time value is received from the PFDF, the configured default caching time value shall be applied.

NOTE 1: The NF service consumer(s) and the PFDF(s) within an operator network are configured with the same default caching time value to be applied for all application identifiers.

NOTE 2: The configuration of a caching time value per application identifier in the PFDF is based on the SLA between the operator and the ASP.

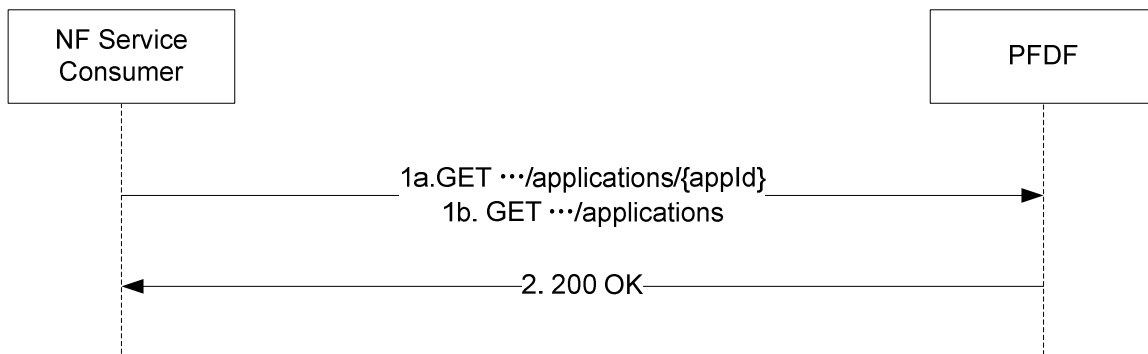

**Figure 4.2.2.2-1: Retrieval of PFDs**

1. The NF service consumer (i.e. SMF) shall send a GET request to the resource representing the PFD for application identifier(s) to be required:
  - for PFD of individual application identifier, the request URI shall include "{apiRoot}/nnef-pfdmanagement/v1/applications/{appld}" (as shown in figure 4.2.2.2-1, step 1a); and
  - for PFD of a collection of application identifiers, the request URI shall include "{apiRoot}/nnef-pfdmanagement/v1/applications" (as shown in figure 4.2.2.2-1, step 1b) with query parameters indicating the requested application identifier(s).
2. On success, "200 OK" shall be returned; the payload body of GET response shall contain a representation of "Individual application PFD" resource or "PFD of applications" resource for the requested application identifier(s). The NF service consumer shall replace the stored PFD(s) retrieved from the PFD with the new received PFD(s) for the requested application identifier(s). If the resource of one or more requested application identifier(s) is not provided in the response, the NF service consumer shall remove the PFD(s) of the requested application identifier(s) which is not included in the response and re-apply the pre-configured PFDs.

On failure, one of the HTTP status code listed in table 5.3.2.3.1-3 or table 5.3.3.3.1-3 shall be returned. For "404 Not Found", the NF service consumer shall remove the PFD(s) of the requested application identifier(s) in the NF service consumer and re-apply the pre-configured PFDs.

### 4.2.3 Nnef\_PFDmanagement\_Subscribe Service Operation

#### 4.2.3.1 General

The Nnef\_PFDmanagement\_Subscribe service operation enables NF service consumer to subscribe the notification of events when the PFDs for application identifier change.

#### 4.2.3.2 Subscription for event notifications on PFDs change

This procedure as shown in Figure 4.2.3.2-1 is used to subscribe the notification of events when the PFDs for application identifier change.

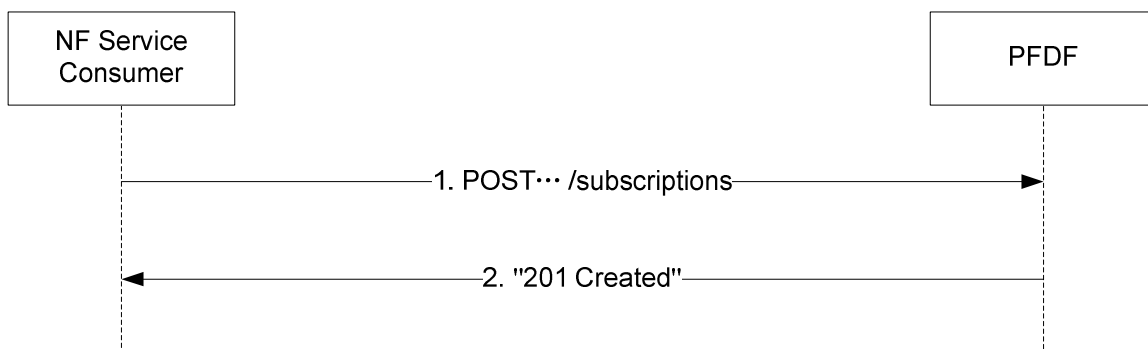

**Figure 4.2.3.2-1: Creation of a subscription**

1. The NF service consumer (i.e. SMF) shall send a POST request to the request URI representing the PFD subscriptions resource "{apiRoot}/nnef-pfdmanagement/v1/subscriptions". The NF service consumer shall include the PfdSubscription data type in the request payload body. Within the PfdSubscription data type, the NF service consumer shall include:
  - an URI where to receive the requested notifications as "notifyUri" attribute;
 may include:
  - subscribed application identifier(s) within the "applicationIds" attribute.
2. If the request is accepted, the PFDF shall:
  - create a new subscription;
  - assign an subscriptionId;
  - store the subscription; and
  - send the response with "201 Created". The payload body shall contain a representation of the created subscription, and the Location header shall contain the URI of the created subscription "{apiRoot}/nnef-pfdmanagement/v1/subscriptions/{subscriptionId}".

Otherwise, one of the HTTP status code listed in table 5.3.4.3.1-3 shall be returned.

NOTE: The PFDs that have been provisioned to the PFDF before the NF service consumer performs the subscription are not notified to the NF service consumer as a result of this subscription, but the NF service consumer can retrieve them before performing the subscription by invoking Nnef\_PFDmanagement\_Fetch Service Operation.

## 4.2.4 Nnef\_PFDmanagement\_Notify Service Operation

### 4.2.4.1 General

The Nnef\_PFDmanagement\_Notify service operation notifies the NF service consumer to update and/or delete the PFDs for application identifier(s).

The following procedures using the Nnef\_PFDmanagement\_Notify service operation are supported:

- Management of PFDs.

### 4.2.4.2 Notification of PFD change

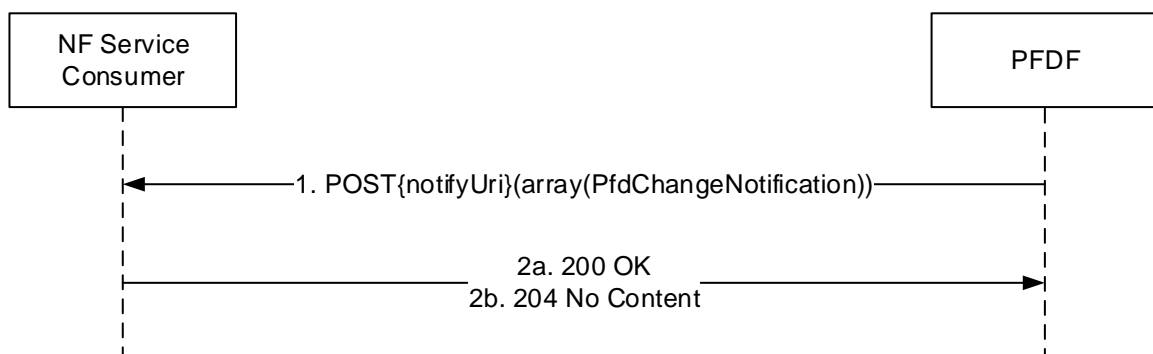

Figure 4.2.4.2-1: Notification of PFD change

1. The PFDF shall send a POST request to the NF service consumer (i.e. SMF) using the notifyUri provided during creation of the subscription resource as specified in subclause 5.6.2.3. The payload body of the POST request shall contain one or more PfdChangeNotification data structure(s).
2. If the notification is accepted, the NF service consumer shall reply with: