

SLOVENSKI STANDARD

SIST EN 4165-026:2019

01-marec-2019

Nadomešča:

SIST EN 4165-026:2016

Aeronavtika - Konektor, električni, pravokotni, modularni - Stalna delovna temperatura 175 °C - 026. del: Pribor za enojne module - Standard za proizvod

Aerospace series - Connector, electrical, rectangular, modular - Operating temperature 175 °C continuous - Part 026: Accessories for single module connector - Product standard

iTeh STANDARD PREVIEW

Luft- und Raumfahrt - Elektrischer Rechtecksteckverbinder in modularer Bauweise - Betriebstemperatur 175 °C konstant - Teil 026: Endgehäuse für Steckverbinder, für ein Modul - Produktnorm

[SIST EN 4165-026:2019](https://standards.iteh.ai/catalog/standards/sist/6bd9e126-04f7-40ba-acb5-51415a073700/sist-en-4165-026-2019)

[https://standards.iteh.ai/catalog/standards/sist/6bd9e126-04f7-40ba-acb5-](https://standards.iteh.ai/catalog/standards/sist/6bd9e126-04f7-40ba-acb5-51415a073700/sist-en-4165-026-2019)

Série aérospatiale - Connecteurs électriques, rectangulaires, modulaires - Température d'utilisation 175 °C continu - Partie 026 : Accessoires pour connecteur mono-module - Norme de produit

Ta slovenski standard je istoveten z: EN 4165-026:2018

ICS:

31.220.10	Vtiči in vtičnice, konektorji	Plug-and-socket devices. Connectors
49.060	Letalska in vesoljska električna oprema in sistemi	Aerospace electric equipment and systems

SIST EN 4165-026:2019

en,fr,de

iTeh STANDARD PREVIEW
(standards.iteh.ai)

SIST EN 4165-026:2019

<https://standards.iteh.ai/catalog/standards/sist/6bd9e126-04f7-40ba-acb5-51e85a075aea/sist-en-4165-026-2019>

EUROPEAN STANDARD

EN 4165-026

NORME EUROPÉENNE

EUROPÄISCHE NORM

December 2018

ICS 49.060

Supersedes EN 4165-026:2015

English Version

**Aerospace series - Connector, electrical, rectangular,
modular - Operating temperature 175 °C continuous - Part
026: Accessories for single module connector - Product
standard**

Série aérospatiale - Connecteurs électriques,
rectangulaires, modulaires - Température d'utilisation
175 °C continu - Partie 026 : Accessoires pour
connecteur mono-module - Norme de produit

Luft- und Raumfahrt - Elektrischer
Rechtecksteckverbinder in modularer Bauweise -
Betriebstemperatur 175 °C konstant - Teil 026:
Endgehäuse für Steckverbinder, für ein Modul -
Produktnorm

This European Standard was approved by CEN on 27 May 2018.

CEN members are bound to comply with the CEN/CENELEC Internal Regulations which stipulate the conditions for giving this European Standard the status of a national standard without any alteration. Up-to-date lists and bibliographical references concerning such national standards may be obtained on application to the CEN-CENELEC Management Centre or to any CEN member.

This European Standard exists in three official versions (English, French, German). A version in any other language made by translation under the responsibility of a CEN member into its own language and notified to the CEN-CENELEC Management Centre has the same status as the official versions.

CEN members are the national standards bodies of Austria, Belgium, Bulgaria, Croatia, Cyprus, Czech Republic, Denmark, Estonia, Finland, Former Yugoslav Republic of Macedonia, France, Germany, Greece, Hungary, Iceland, Ireland, Italy, Latvia, Lithuania, Luxembourg, Malta, Netherlands, Norway, Poland, Portugal, Romania, Serbia, Slovakia, Slovenia, Spain, Sweden, Switzerland, Turkey and United Kingdom.



EUROPEAN COMMITTEE FOR STANDARDIZATION
COMITÉ EUROPÉEN DE NORMALISATION
EUROPÄISCHES KOMITEE FÜR NORMUNG

CEN-CENELEC Management Centre: Rue de la Science 23, B-1040 Brussels

Contents		Page
European foreword		3
1	Scope.....	4
2	Normative references.....	4
3	Terms and definitions	4
4	Required characteristics	5
5	Designation	16
6	Marking.....	17
7	Technical specification	17

iTeh STANDARD PREVIEW
(standards.iteh.ai)

[SIST EN 4165-026:2019](https://standards.iteh.ai/catalog/standards/sist/6bd9e126-04f7-40ba-acb5-51e85a075aea/sist-en-4165-026-2019)

<https://standards.iteh.ai/catalog/standards/sist/6bd9e126-04f7-40ba-acb5-51e85a075aea/sist-en-4165-026-2019>

European foreword

This document (EN 4165-026:2018) has been prepared by the Aerospace and Defence Industries Association of Europe - Standardization (ASD-STAN).

After enquiries and votes carried out in accordance with the rules of this Association, this Standard has received the approval of the National Associations and the Official Services of the member countries of ASD, prior to its presentation to CEN.

This European Standard shall be given the status of a national standard, either by publication of an identical text or by endorsement, at the latest by June 2019, and conflicting national standards shall be withdrawn at the latest by June 2019.

Attention is drawn to the possibility that some of the elements of this document may be the subject of patent rights. CEN [and/or CENELEC] shall not be held responsible for identifying any or all such patent rights.

This document supersedes EN 4165-026:2015.

According to the CEN-CENELEC Internal Regulations, the national standards organizations of the following countries are bound to implement this European Standard: Austria, Belgium, Bulgaria, Croatia, Cyprus, Czech Republic, Denmark, Estonia, Finland, Former Yugoslav Republic of Macedonia, France, Germany, Greece, Hungary, Iceland, Ireland, Italy, Latvia, Lithuania, Luxembourg, Malta, Netherlands, Norway, Poland, Portugal, Romania, Serbia, Slovakia, Slovenia, Spain, Sweden, Switzerland, Turkey and the United Kingdom.

(standards.iteh.ai)

[SIST EN 4165-026:2019](https://standards.iteh.ai/catalog/standards/sist/6bd9e126-04f7-40ba-acb5-51e85a075aea/sist-en-4165-026-2019)

<https://standards.iteh.ai/catalog/standards/sist/6bd9e126-04f7-40ba-acb5-51e85a075aea/sist-en-4165-026-2019>

EN 4165-026:2018 (E)**1 Scope**

This document defines accessories of single modules connectors according to EN 4165-024 and EN 4165-025 used in the family of rectangular electrical connectors.

2 Normative references

The following documents are referred to in the text in such a way that some or all of their content constitutes requirements of this document. For dated references, only the edition cited applies. For undated references, the latest edition of the referenced document (including any amendments) applies.

EN 3660-033, *Aerospace series — Cable outlet accessories for circular and rectangular electrical and optical connectors — Part 033: Stainless steel banding band, style Z, for attachment of individual and/or overall screens to cable outlets — Product standard*¹⁾

EN 4165-001, *Aerospace series — Connectors, electrical, rectangular, modular — Operating temperature 175 °C continuous — Part 001: Technical specification*

EN 4165-002, *Aerospace series — Connectors, electrical, rectangular, modular — Operating temperature 175 °C continuous — Part 002: Specification of performance and contact arrangements*

EN 4165-024, *Aerospace series — Connectors, electrical, rectangular, modular — Operating temperature 175 °C continuous — Part 024: Single module plug — Product standard*

EN 4165-025, *Aerospace series — Connectors, electrical, rectangular, modular — Operating temperature 175 °C continuous — Part 025: Single module receptacle — Product standard*

3 Terms and definitions

[SIST EN 4165-026:2019](https://standards.iteh.ai/catalog/standards/sist/6bd9e126-04f7-40ba-acb5-51e85a0751ea/sist-en-4165-026-2019)

[https://standards.iteh.ai/catalog/standards/sist/6bd9e126-04f7-40ba-acb5-](https://standards.iteh.ai/catalog/standards/sist/6bd9e126-04f7-40ba-acb5-51e85a0751ea/sist-en-4165-026-2019)

[51e85a0751ea/sist-en-4165-026-2019](https://standards.iteh.ai/catalog/standards/sist/6bd9e126-04f7-40ba-acb5-51e85a0751ea/sist-en-4165-026-2019)

For the purposes of this document, the terms and definitions given in EN 4165-001 apply.

ISO and IEC maintain terminological databases for use in standardization at the following addresses:

- IEC Electropedia: available at <http://www.electropedia.org/>
- ISO Online browsing platform: available at <http://www.iso.org/obp>

¹⁾ Published as ASD-STAN Prestandard at the date of publication of this standard by AeroSpace and Defence industries Association of Europe - Standardization (ASD-STAN), <http://www.asd-stan.org/>

4 Required characteristics

4.1 Shielded accessories for single module connector

See attachment principle on Figure 1.

Always delivered with attachment system.

NOTE No accessory is standardized to fit the single-module connectors with contact size 8 module (according to EN 4165-002) – a new accessory must be required for standardization if specific need exists.

Alternative design:

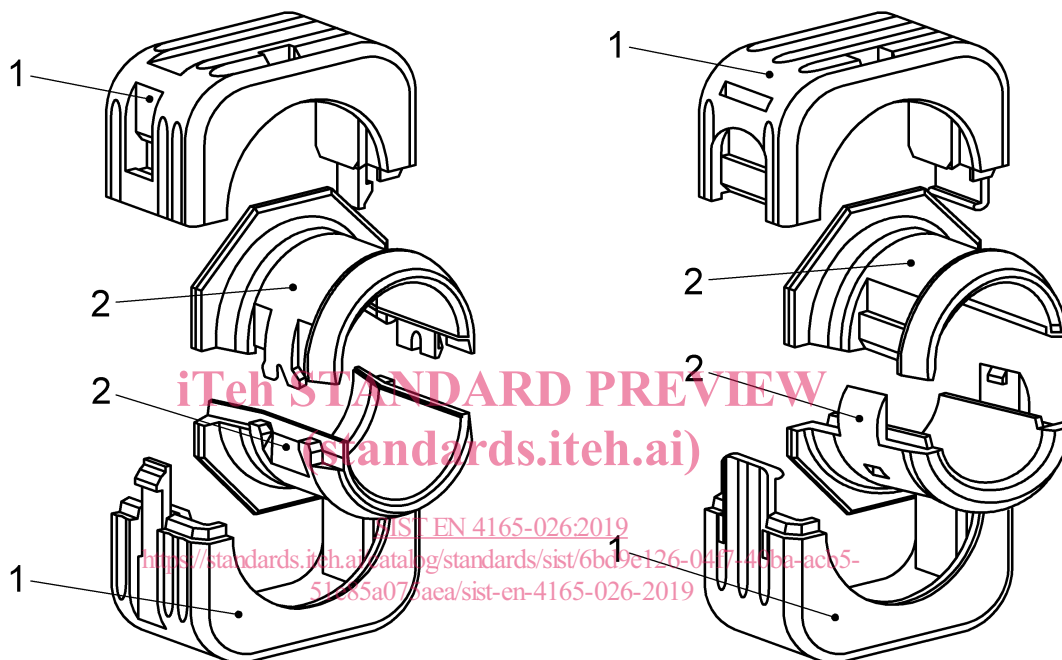

Key

- 1 Accessory attachment system consisting of half clips
- 2 Accessory system consisting of two half sections permitting the termination of shielding using EN 3660-033 banding strap or equivalent

In case of 45° and 90° accessories, numbering system permit to give indication of angular position of the accessory.

Figure 1 — Accessory assembly

See Figure 2.

Dimensions in millimetres

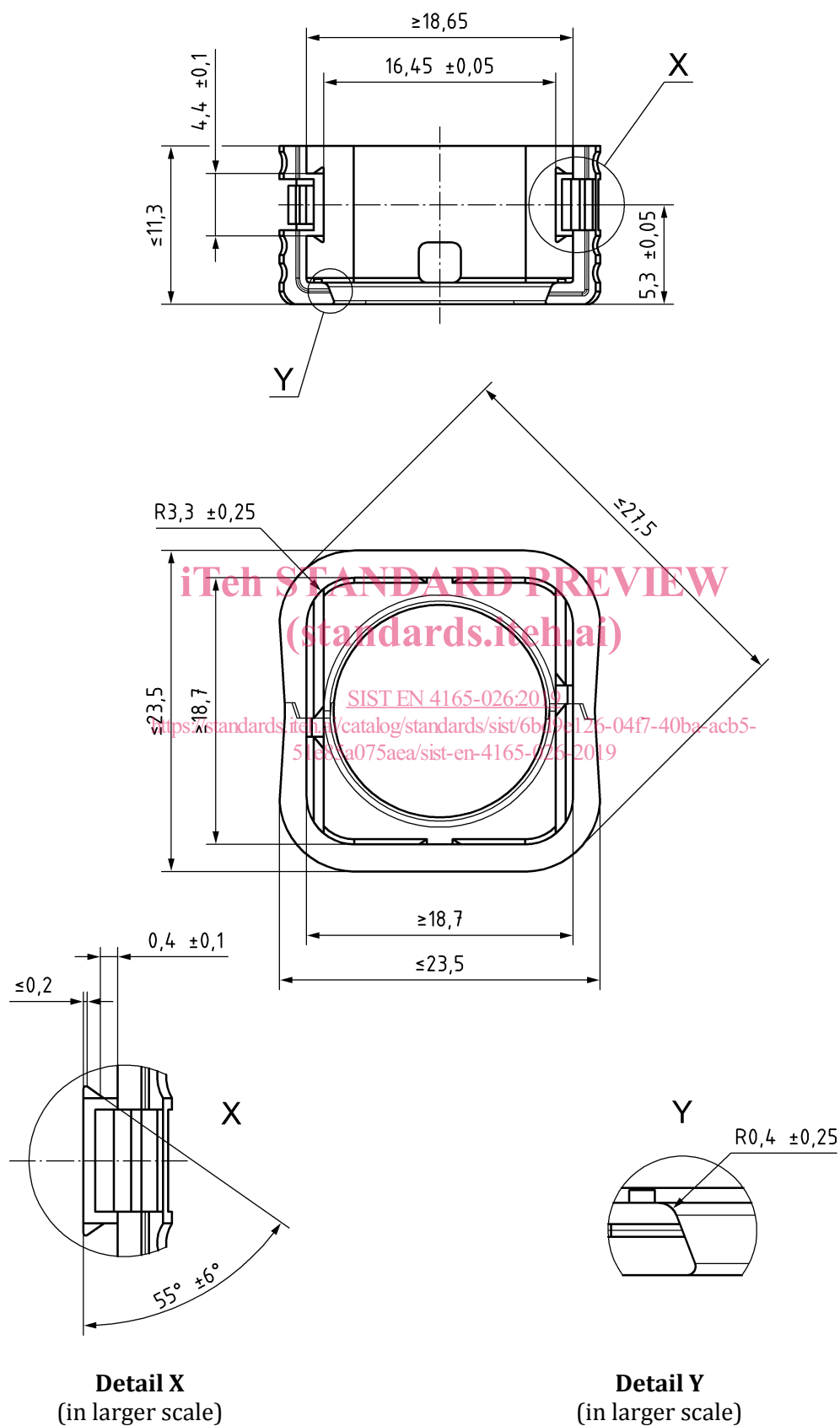

Figure 2 — Accessory attachment system

4.1.1 Straight accessory - Without type code

See Figure 3.

Mass: 5,6 g max.

Dimensions in millimetres

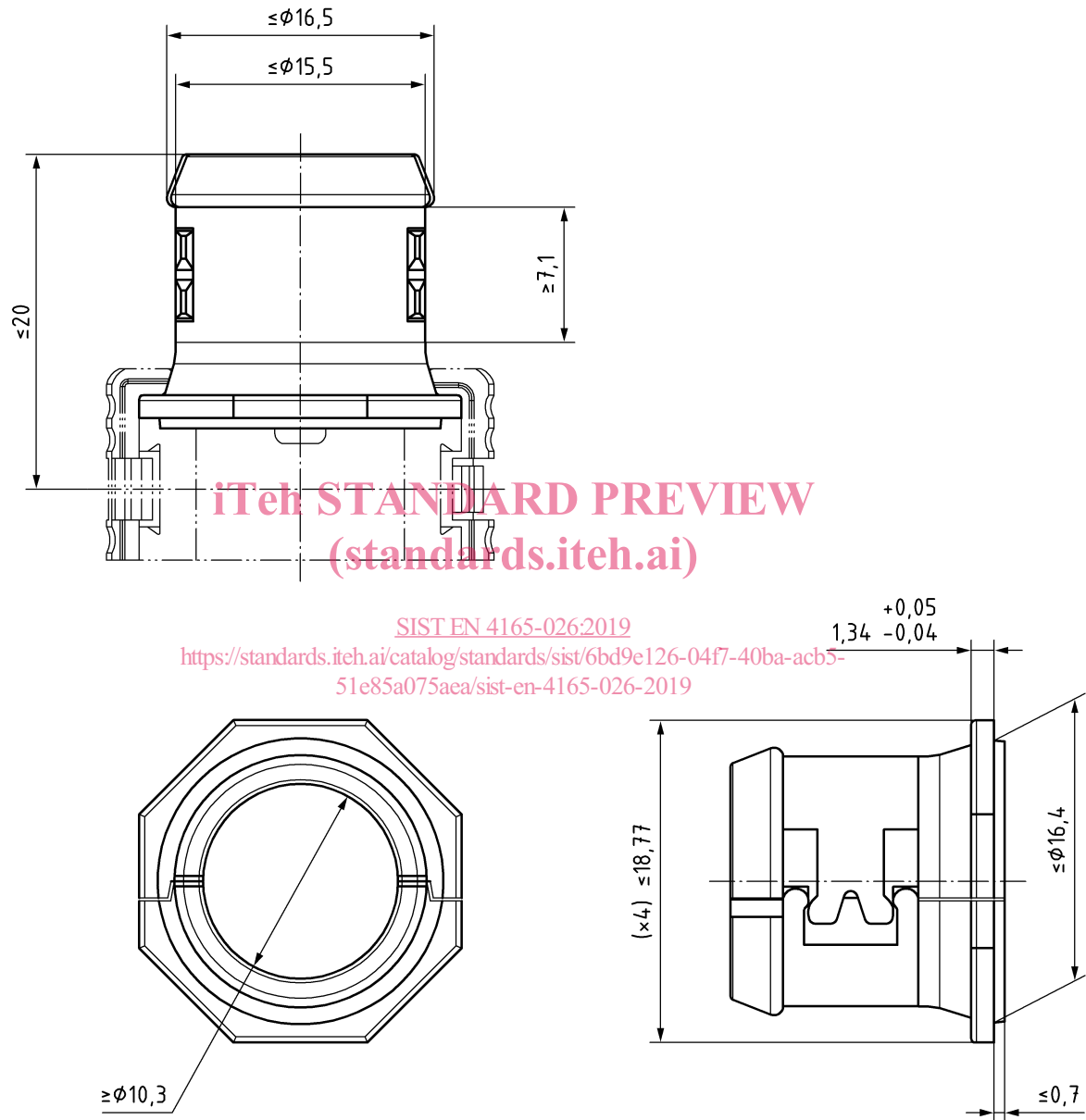

Figure 3 — Straight accessory