**Furniture — Beds — Test methods for
the determination of stability, strength
and durability**

*Ameublement — Couchages — Méthodes d'essai pour la
détermination de la stabilité, de la résistance et de la durabilité*

iTeh STANDARD PREVIEW
(standards.iteh.ai)

[ISO 19833:2018](https://standards.iteh.ai/catalog/standards/sist/081a6e05-9efd-4899-914e-ffe37b7334c1/iso-19833-2018)

<https://standards.iteh.ai/catalog/standards/sist/081a6e05-9efd-4899-914e-ffe37b7334c1/iso-19833-2018>



iTeh STANDARD PREVIEW
(standards.iteh.ai)

ISO 19833:2018

<https://standards.iteh.ai/catalog/standards/sist/081a6e05-9efd-4899-914e-ffe37b7334c1/iso-19833-2018>



COPYRIGHT PROTECTED DOCUMENT

© ISO 2018

All rights reserved. Unless otherwise specified, or required in the context of its implementation, no part of this publication may be reproduced or utilized otherwise in any form or by any means, electronic or mechanical, including photocopying, or posting on the internet or an intranet, without prior written permission. Permission can be requested from either ISO at the address below or ISO's member body in the country of the requester.

ISO copyright office
CP 401 • Ch. de Blandonnet 8
CH-1214 Vernier, Geneva
Phone: +41 22 749 01 11
Fax: +41 22 749 09 47
Email: copyright@iso.org
Website: www.iso.org

Published in Switzerland

Contents

	Page
Foreword	iv
1 Scope	1
2 Normative references	1
3 Terms and definitions	1
4 General test conditions	2
4.1 Preliminary preparation.....	2
4.2 Application of forces.....	2
4.3 Tolerances.....	2
4.4 Sequence of testing.....	3
4.5 Loading.....	3
5 Test apparatus	3
6 Test procedures — Stability, strength and durability	7
6.1 General.....	7
6.2 Stability test.....	8
6.3 Vertical static load tests.....	10
6.3.1 Vertical static load on bed base.....	10
6.3.2 Vertical static load on side rail.....	10
6.4 Horizontal static load tests.....	11
6.4.1 Horizontal static load on headboard of beds ≤ 1 200 mm in width.....	11
6.4.2 Horizontal static load on headboard of beds > 1 200 mm in width.....	12
6.4.3 Horizontal static load test for beds without headboards.....	13
6.5 Durability tests.....	14
6.5.1 Vertical durability test of bed base.....	14
6.5.2 Horizontal durability test of bed frame.....	15
6.6 Vertical impact test.....	18
7 Test procedures — Mechanisms for lifting bed bases	19
7.1 General.....	19
7.2 Durability of mechanisms for lifting bed bases.....	19
8 Test report	20
Annex A (informative) Guidance for the choice of loads, cycles etc. for stability, strength and durability tests of beds	21

Foreword

ISO (the International Organization for Standardization) is a worldwide federation of national standards bodies (ISO member bodies). The work of preparing International Standards is normally carried out through ISO technical committees. Each member body interested in a subject for which a technical committee has been established has the right to be represented on that committee. International organizations, governmental and non-governmental, in liaison with ISO, also take part in the work. ISO collaborates closely with the International Electrotechnical Commission (IEC) on all matters of electrotechnical standardization.

The procedures used to develop this document and those intended for its further maintenance are described in the ISO/IEC Directives, Part 1. In particular the different approval criteria needed for the different types of ISO documents should be noted. This document was drafted in accordance with the editorial rules of the ISO/IEC Directives, Part 2 (see www.iso.org/directives).

Attention is drawn to the possibility that some of the elements of this document may be the subject of patent rights. ISO shall not be held responsible for identifying any or all such patent rights. Details of any patent rights identified during the development of the document will be in the Introduction and/or on the ISO list of patent declarations received (see www.iso.org/patents).

Any trade name used in this document is information given for the convenience of users and does not constitute an endorsement.

For an explanation on the voluntary nature of standards, the meaning of ISO specific terms and expressions related to conformity assessment, as well as information about ISO's adherence to the World Trade Organization (WTO) principles in the Technical Barriers to Trade (TBT) see the following URL: www.iso.org/iso/foreword.html. (standards.iteh.ai)

This document was prepared by ISO/TC 136, *Furniture*.

ISO 19833:2018

<https://standards.iteh.ai/catalog/standards/sist/081a6e05-9efd-4899-914e-ffe37b7334c1/iso-19833-2018>

Furniture — Beds — Test methods for the determination of stability, strength and durability

1 Scope

This document specifies test methods for determining the stability, strength and durability of all types of fully assembled beds including bed frames and bed bases.

This document applies to adult beds for domestic and non-domestic use. It does not apply to waterbeds, airbeds, foldaway beds, bunk beds and beds for people with special needs, nor to beds for healthcare and medical purposes.

Test methods for the assessment of ageing, degradation, fire resistance and electrical functions are not included in this document.

Other methods for the strength and durability of storage components, seating surfaces and other features associated with beds are covered by other standards.

Where a bed incorporates additional functions such as storage, electrical adjustability or conversion from a sofa to a bed, additional tests are applicable.

This document does not specify requirements for the choice of loads, cycles or forces. These can be specified in a requirements document. If this is not available, suggested loads and cycles can be found in [Annex A](#) (informative).

The tests are not intended to assess the durability of upholstery, e.g. filling materials and covers.

<https://standards.iteh.ai/catalog/standards/sist/081a6e05-9efd-4899-914e-ffe37b7334c1/iso-19833-2018>

2 Normative references

The following documents are referred to in the text in such a way that some or all of their content constitutes requirements of this document. For dated references, only the edition cited applies. For undated references, the latest edition of the referenced document (including any amendments) applies.

ISO 2439:2008, *Flexible cellular polymeric materials — Determination of hardness (indentation technique)*

3 Terms and definitions

For the purposes of this document, the following terms and definitions apply.

ISO and IEC maintain terminological databases for use in standardization at the following addresses:

- IEC Electropedia: available at <http://www.electropedia.org/>
- ISO Online browsing platform: available at <https://www.iso.org/obp>

3.1

unframed slat base

bed base consisting of separate slats flexibly held together normally by means of textile, rubber or plastic tape

Note 1 to entry: When loading one slat, the load is transferred to the support by that slat only.

3.2 framed base

bed base consisting of slats, springs, etc., which are connected to a structural frame system

Note 1 to entry: When loading one component only, e.g. a slat or a spring, the load is distributed by the frame to the support.

4 General test conditions

4.1 Preliminary preparation

The tests are designed to be applied to a bed that is fully assembled and ready for use. The bed shall be assembled in accordance with instructions supplied by the manufacturer. If the bed can be assembled or combined in different ways, the most adverse combination shall be used for each test. If mounting or assembly instructions are not supplied, the mounting or assembly method shall be recorded in the test report. Fastenings shall be tightened before testing and shall not be re-tightened unless this is specified in the manufacturer's instructions. If the configuration needs to be changed in order to produce the worst-case conditions, this shall be recorded in the test report.

Unless otherwise specified by the manufacturer, the test item shall be stored in indoor ambient conditions for at least 24 h immediately prior to testing.

The tests shall be carried out in indoor ambient conditions at a temperature between 15 °C and 25 °C. If, during a test, the temperature is outside this range, the maximum and/or minimum temperature shall be recorded in the test report.

Before beginning the test, visually inspect the bed thoroughly. Record any defects so that they are not assumed to have been caused by the tests.

4.2 Application of forces

The test forces in the static load tests shall be applied slowly enough to ensure that negligible dynamic force is applied.

Unless otherwise indicated, each force shall be maintained for (10 ± 2) s. Forces shall be as specified in the requirements document or should be as suggested in [Annex A](#).

The test forces in durability tests shall be applied at a rate such that excessive heating does not occur. Unless otherwise specified, each test force shall be maintained for (2 ± 1) s.

The forces may be replaced by masses. The relationship $10 \text{ N} = 1 \text{ kg}$ shall be used.

4.3 Tolerances

Unless otherwise stated, the following tolerances are applicable:

- forces: ± 5 % of the nominal force;
- masses: ± 1 % of the nominal mass;
- dimensions: all dimensions less than 200 mm shall have an accuracy of ± 1 mm of the nominal dimension; the other dimensions shall have an accuracy of $\pm 0,5$ %; the dimension of the spherical curvature of 300 mm radius on the loading pad (5.3) shall have an accuracy of ± 5 mm.

The accuracy for the position of loading pads and impactor shall be ± 5 mm.

NOTE For the purposes of uncertainty measurement, test results are not considered to be adversely affected when the above tolerances are met.

4.4 Sequence of testing

Unless otherwise specified in the requirements document, all applicable tests as shown in [Table 1](#) shall be carried out on the same sample and in the sequence as the clauses are numbered in this document.

4.5 Loading

Unless otherwise specified, all storage components supplied with beds, which are not subject to testing, shall be uniformly loaded with the load(s) as specified in the requirements document or should be loaded with the load(s) as suggested in [Annex A](#).

5 Test apparatus

Unless otherwise specified, the tests may be applied by any suitable device because the results are not dependent upon the apparatus.

The equipment shall not inhibit deformation nor cause unnatural deformation of the unit/component, i.e. it shall be able to move so that it can follow the deformation of the unit/component during testing.

All loading pads shall be capable of pivoting in all directions. The pivot point shall be as close as practically possible to the load surface.

5.1 Floor surface.

The floor surface shall be horizontal, rigid and flat with a smooth surface.

For the test in [6.5.2](#), the surface shall be smooth high-pressure plastic laminate or equivalent.

5.2 Stops.

The stops are devices to prevent the article from sliding but not tilting. They shall not be higher than 12 mm, except where the design of the bed necessitates the use of higher stops, in which case the lowest stop that will prevent the item from moving shall be used. If greater than 12 mm, the height of the stop used shall be recorded in the test report.

5.3 Loading pad.

The loading pad shall be a rigid circular object, 200 mm in diameter, the face of which shall have a convex spherical curvature of 300 mm radius with a 12 mm front edge radius (see [Figure 1](#)).

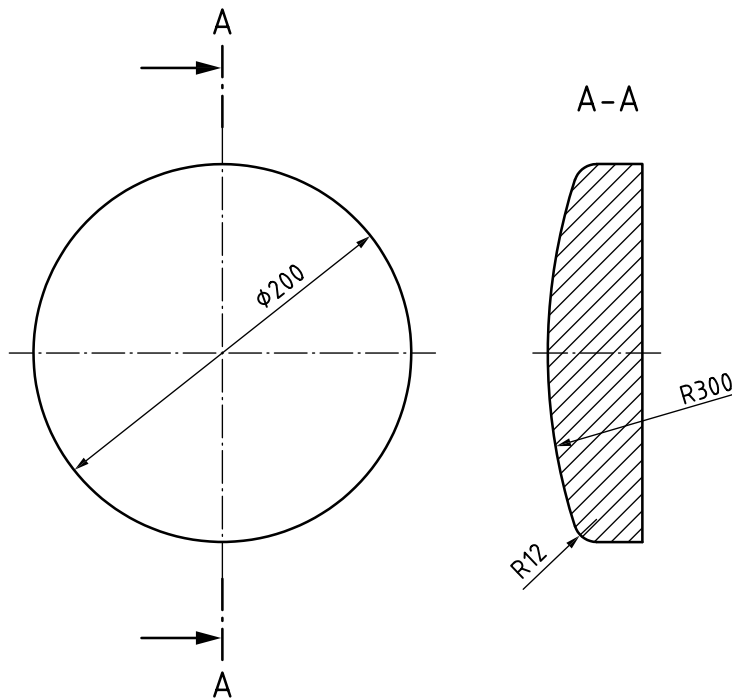

Figure 1 Loading pad
 iTeh STANDARD PREVIEW
 (standards.iteh.ai)

5.4 Small loading pad.

The small loading pad shall be a rigid disc 100 mm in diameter, with a flat face and a 12 mm front edge bend radius. Where space prevents the use of a 100 mm diameter loading pad, a 50 mm diameter loading pad with similar properties may be used.

5.5 Test mattress.

The test mattress shall be a soft polyether foam sheet with a thickness of 100 mm, a bulk density of $(35 \pm 3,5) \text{ kg/m}^3$ and an indentation hardness index of $(170 \pm 40) \text{ N}$ in accordance with Method A, $HA_{(40\%/30s)}$ as given in ISO 2439:2008. The size shall be such as to overlap the size of the loading pad by at least 200 mm all round. The test mattress may have a light soft cotton cover with a mass not greater than 120 g/m^2 .

The same part of the standard test mattress shall not be reused within 2 h and the mattress shall be replaced if damaged, or after 10 complete bed tests, whichever occurs first.

5.6 Impactor.

The impactor shall be as shown in Figure 2 and comprised of the following:

5.6.1 Circular body, approximately 200 mm in diameter separated from the striking surface by helical compression springs and free to move relative to it on a line perpendicular to the plane of the central area of the striking surface.

The body and associated parts minus the spring shall have a mass of $(17 \pm 0,1) \text{ kg}$ and the whole apparatus shall have a mass of $(25 \pm 0,1) \text{ kg}$.

5.6.2 Springs, which shall be such that the combined spring system has a nominal spring rate of (7 ± 2) N/mm and the total friction resistance of the moving parts is less than 1 N.

The spring system shall be compressed to an initial load of $(1\ 040 \pm 5)$ N (measured statically) and the amount of spring compression movement available from the initial compression point to the point where the springs become fully closed shall be not less than 60 mm.

5.6.3 Striking surface, which shall be a rigid circular object, 200 mm in diameter, the face of which has a convex spherical curvature of 300 mm radius with a 12 mm front edge radius.

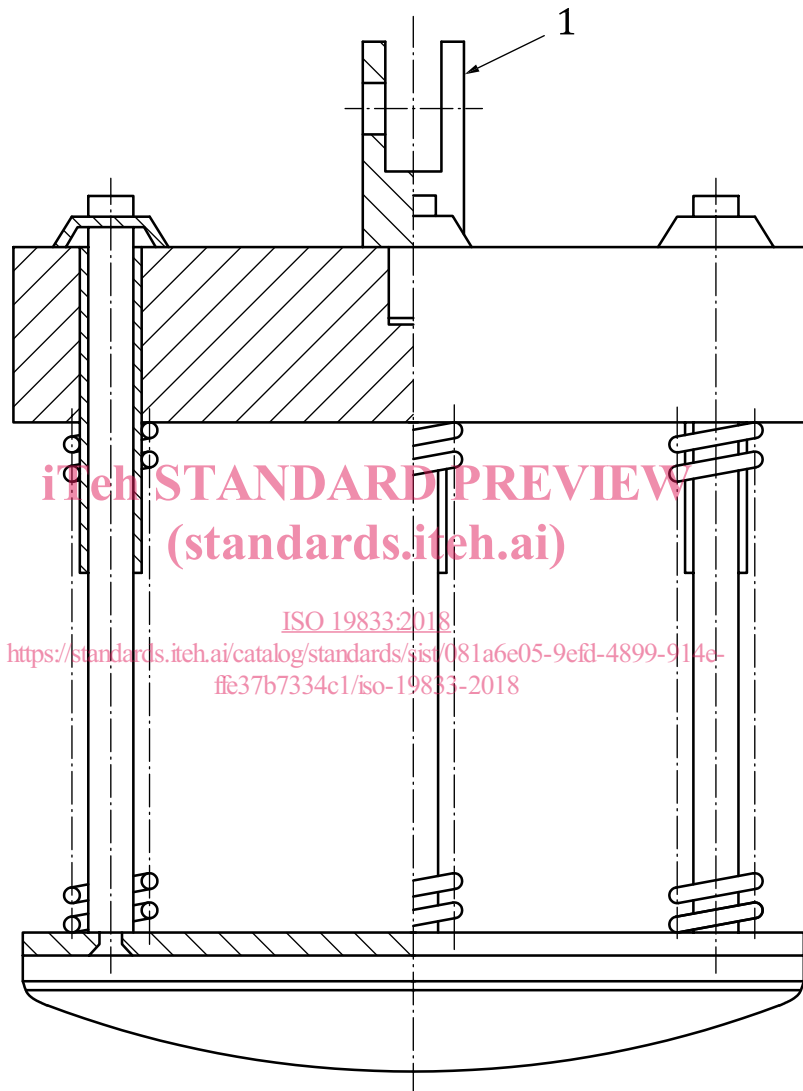

Key

1 joint of lifting device not inhibiting free fall

Figure 2 — Impactor

5.7 Test bed base (unframed).

The slats should be made of solid wood with a minimum modulus of elasticity of $8\ 000$ N/mm² [e.g. European beech (*Fagus sylvatica*) or Pine (*Pinus ssp*), etc.].

The cross section of the slats shall be $20\text{ mm} \times 95\text{ mm}$ and the distance between the slats shall be (60 ± 2) mm.

If the free span of the slats is >1 000 mm, support the slats along the centre line.
 The length of the slats shall be 10 mm shorter than the nominal width of the bed frame.

5.8 Test bed base (framed).

The slats shall be as described in 5.7.

They shall be mounted on a frame made of wooden material defined in 5.7 with a cross section of 20 mm × 45 mm (see Figure 3).

The width of the bed base shall be 20 mm smaller than the nominal width of the bed frame.

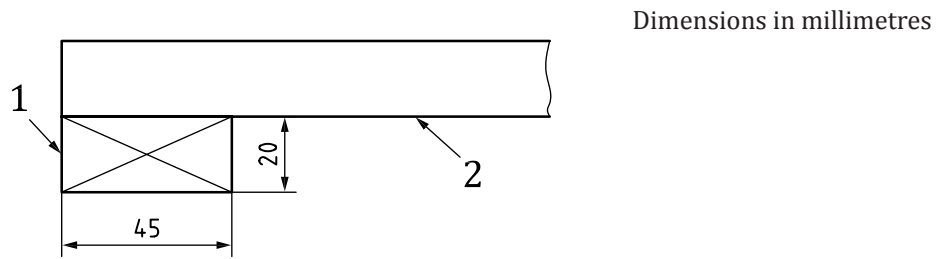

- Key**
- 1 frame
 - 2 slat

iTeh STANDARD PREVIEW
Figure 3 — Test bed base (framed)
 (standards.iteh.ai)

5.9 Test support (unframed bed bases). [ISO 19833:2018](https://standards.iteh.ai/catalog/standards/sist/081a6e05-9efd-4899-914e-833-2018)
<https://standards.iteh.ai/catalog/standards/sist/081a6e05-9efd-4899-914e-833-2018>

The base shall be suitably supported along its whole length

The total overhang on one side (see Figure 4) shall be (20 ± 1) mm.

If the bed base is not prevented from moving during the tests, it shall be fixed in a suitable manner.

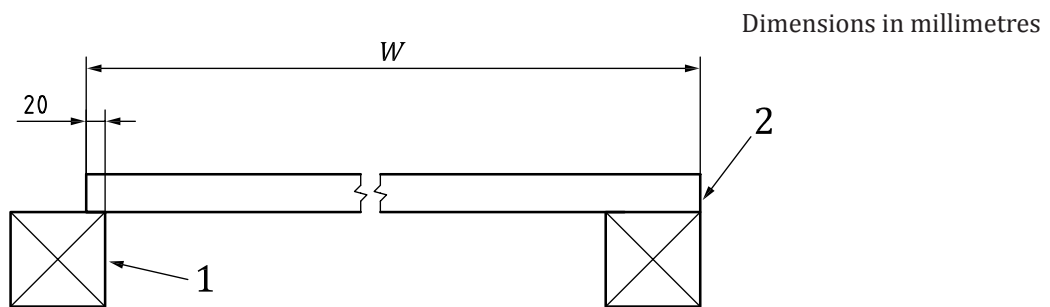

- Key**
- 1 test support
 - 2 slat
 - W width of the base

Figure 4 — Test support (unframed bed bases)

5.10 Test support (framed bed bases).

Supports of 50 mm width, suitable to carry the bed base and the test loads, shall be placed 150 mm from the ends of the frame (see Figure 5).

Dimensions in millimetres

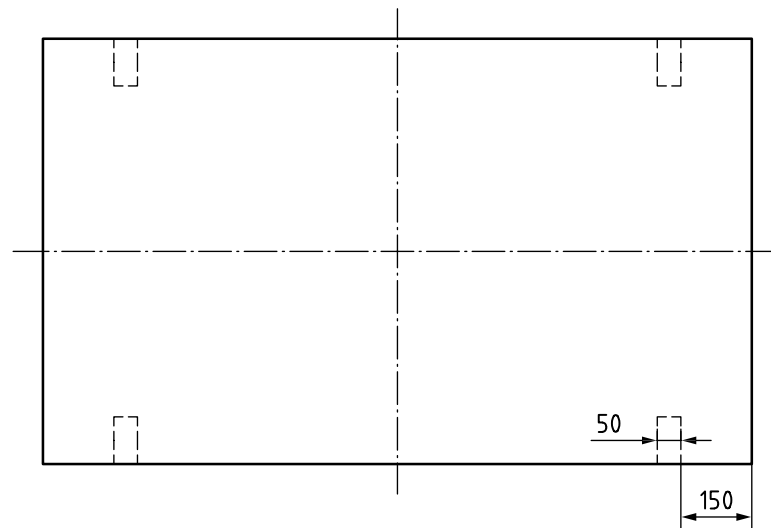

Figure 5 — Test support (framed bed bases)

5.11 Test mass.

A mass of 75 kg should be distributed over an area of approximately 300 mm × 300 mm or a diameter of approximately 340 mm.

STANDARD PREVIEW
(standards.iteh.ai)

6 Test procedures — Stability, strength and durability

ISO 19833:2018

6.1 General <https://standards.iteh.ai/catalog/standards/sist/081a6e05-9efd-4899-914e-f5e37b7334c1/iso-19833-2018>

Unless otherwise specified, the test shall be carried out in the configuration most likely to cause failure.

When the mattress, bed base and frame (if applicable) are supplied together as a bed set, they shall be tested together.

When other components are supplied separately, they shall be tested using the test mattress, test support or test bed base described in [Clause 5](#), unless otherwise specified by the manufacturer of the components under test.

If a test cannot be carried out as specified in this document, e.g. because a loading pad cannot be used to apply a force due to the shape of a product, the test shall be carried out as closely as possible to the specifications of this document, and any deviations shall be recorded in the test report.

[Table 1](#) shows which tests are applicable to a bed set and which to parts of a bed.

Table 1 — Testing of beds, bed frames and bed bases

Test	6.2	6.3.1	6.3.2	6.4	6.5.1	6.5.2	6.6
Complete bed	√	√	√	√	√	√	√
Bed base	(√)	√	(√)	(√)	√	(√)	√
Bed frame	√	√	√	√	(√)	√	(√)
(√) = if applicable							
√ = test to be carried out							