Aerospace — Nuts, hexagonal, plain, reduced height, normal across flats, with MJ threads, classifications:
450 MPa (at ambient temperature) /120 °C, 450 MPa (at ambient temperature) /235 °C, 600 MPa (at ambient temperature) /425 °C, 900 MPa (at ambient temperature) /235 °C, 900 MPa (at ambient temperature) /315 °C, 900 MPa (at ambient temperature) /650 °C, 1 100 MPa (at ambient temperature) /235 °C, 1 100 MPa (at ambient temperature) /730 °C and 1 250 MPa (at ambient temperature) /600 °C — Dimensions

iTeh STANDARD PREVIEW
(standards.iteh.ai)
ISO 9609:2016
<https://standards.iteh.ai/catalog/standards/sis/52a8b010-6808-4689-bc2c-fc1559e1a149/iso-9609-2016>



iTeh STANDARD PREVIEW
(standards.iteh.ai)

ISO 9609:2016

<https://standards.iteh.ai/catalog/standards/sist/52a8b616-6808-4689-be2e-93c61c529420/iso-9609-2016>



COPYRIGHT PROTECTED DOCUMENT

© ISO 2016, Published in Switzerland

All rights reserved. Unless otherwise specified, no part of this publication may be reproduced or utilized otherwise in any form or by any means, electronic or mechanical, including photocopying, or posting on the internet or an intranet, without prior written permission. Permission can be requested from either ISO at the address below or ISO's member body in the country of the requester.

ISO copyright office
Ch. de Blandonnet 8 • CP 401
CH-1214 Vernier, Geneva, Switzerland
Tel. +41 22 749 01 11
Fax +41 22 749 09 47
copyright@iso.org
www.iso.org

Contents

	Page
Foreword.....	iv
Introduction.....	v
1 Scope.....	1
2 Normative references.....	1
3 Configuration and dimensions.....	1

iTeh STANDARD PREVIEW (standards.iteh.ai)

[ISO 9609:2016](https://standards.iteh.ai/catalog/standards/sist/52a8b616-6808-4689-be2e-93c61c529420/iso-9609-2016)

<https://standards.iteh.ai/catalog/standards/sist/52a8b616-6808-4689-be2e-93c61c529420/iso-9609-2016>

Foreword

ISO (the International Organization for Standardization) is a worldwide federation of national standards bodies (ISO member bodies). The work of preparing International Standards is normally carried out through ISO technical committees. Each member body interested in a subject for which a technical committee has been established has the right to be represented on that committee. International organizations, governmental and non-governmental, in liaison with ISO, also take part in the work. ISO collaborates closely with the International Electrotechnical Commission (IEC) on all matters of electrotechnical standardization.

The procedures used to develop this document and those intended for its further maintenance are described in the ISO/IEC Directives, Part 1. In particular the different approval criteria needed for the different types of ISO documents should be noted. This document was drafted in accordance with the editorial rules of the ISO/IEC Directives, Part 2 (see www.iso.org/directives).

Attention is drawn to the possibility that some of the elements of this document may be the subject of patent rights. ISO shall not be held responsible for identifying any or all such patent rights. Details of any patent rights identified during the development of the document will be in the Introduction and/or on the ISO list of patent declarations received (see www.iso.org/patents).

Any trade name used in this document is information given for the convenience of users and does not constitute an endorsement.

For an explanation on the meaning of ISO specific terms and expressions related to conformity assessment, as well as information about ISO's adherence to the WTO principles in the Technical Barriers to Trade (TBT) see the following URL: [Foreword - Supplementary information](#).

The committee responsible for this document is ISO/TC 20, *Aircraft and space vehicles*, Subcommittee SC 4, *Aerospace fastener systems*.

This second edition cancels and replaces the first edition (ISO 9609:1996), of which it constitutes a minor revision.

Introduction

The dimensions specified in this International Standard have been determined to satisfy the requirements of the procurement specification which will be the subject of a future International Standard.

iTeh STANDARD PREVIEW (standards.iteh.ai)

[ISO 9609:2016](https://standards.iteh.ai/catalog/standards/sist/52a8b616-6808-4689-be2e-93c61c529420/iso-9609-2016)

<https://standards.iteh.ai/catalog/standards/sist/52a8b616-6808-4689-be2e-93c61c529420/iso-9609-2016>

iTeh STANDARD PREVIEW
(standards.iteh.ai)

ISO 9609:2016

<https://standards.iteh.ai/catalog/standards/sist/52a8b616-6808-4689-be2e-93c61c529420/iso-9609-2016>

Aerospace — Nuts, hexagonal, plain, reduced height, normal across flats, with MJ threads, classifications: 450 MPa (at ambient temperature) /120 °C, 450 MPa (at ambient temperature) /235 °C, 600 MPa (at ambient temperature) /425 °C, 900 MPa (at ambient temperature) /235 °C, 900 MPa (at ambient temperature) /315 °C, 900 MPa (at ambient temperature) /650 °C, 1 100 MPa (at ambient temperature) /235 °C, 1 100 MPa (at ambient temperature) /730 °C and 1 250 MPa (at ambient temperature)/600 °C — Dimensions

1 Scope

This International Standard specifies the dimensions of plain, hexagonal nuts, reduced height, normal across flats, with MJ threads, of classifications: 450 MPa/120 °C, 450 MPa/235 °C, 600 MPa/425 °C, 900 MPa/235 °C, 900 MPa/315 °C, 900 MPa/650 °C, 1 100 MPa/235 °C, 1 100 MPa/730 °C, and 1 250 MPa/600 °C.

NOTE 1 450 MPa, 600 MPa, 900 MPa, 1 100 MPa and 1 250 MPa corresponds to the minimum tensile stress which the nut is able to withstand at ambient temperature without breaking or cracking when tested with a bolt of a higher strength class.

NOTE 2 120 °C, 235 °C, 425 °C, 315 °C, 650 °C, 730 °C and 600 °C corresponds to the maximum temperature that the nut is able to withstand without permanent alteration to its original characteristics, after ambient temperature has been restored. The maximum temperature is conditioned by the surface treatment.

Nuts provided with holes are intended to be used with lockwire in conformity with ISO 245.

This International Standard is only applicable for the compilation of aerospace product standards.

2 Normative references

The following documents, in whole or in part, are normatively referenced in this document and are indispensable for its application. For dated references, only the edition cited applies. For undated references, the latest edition of the referenced document (including any amendments) applies.

ISO 245, *Aerospace — Lockwire — Diameters*

ISO 5855-2, *Aerospace — MJ threads — Part 2: Limit dimensions for bolts and nuts*

ISO 8788, *Aerospace — Nuts, metric — Tolerances of form and position*

3 Configuration and dimensions

See [Figure 1](#) and [Table 1](#). Dimensions and tolerances are expressed in millimetres. They apply after any surface coating(s) but before the application of any lubricant.

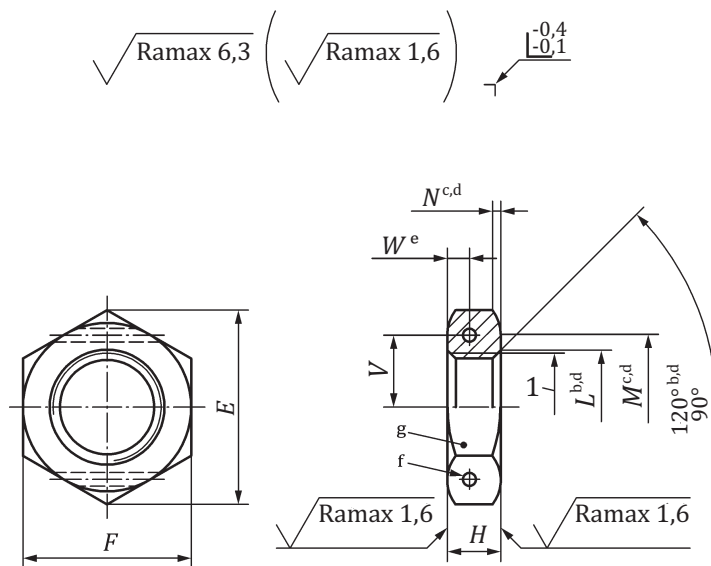

Key

- 1 thread
- a These values, in micrometers, apply before any surface coating(s) is/are applied. The values do not apply to threads the surface texture of which will be as achieved by the usual manufacturing methods.
- b All forms of entry (chamfer or radius) permissible within these limiting dimensions.
- c Form of contour, within limiting dimensions, is left to the manufacturer's discretion. Diameter M may be tangential to, but shall not intrude on the flats.
- d Applicable to both faces.
- e From either face.
- f 2 holes $\varnothing U$ (optional).
- g Marking.

<https://standards.iteh.ai/catalog/standards/sist/52a8b616-6808-4689-be2e-93c61c529420/iso-9609-2016>
 ISO 9609:2016
 (standards.iteh.ai)

NOTE Tolerances of form and position shall conform to those specified in ISO 8788.

Figure 1 — Configuration and dimensions

Table 1 — Dimensions

Dimensions in millimetres

Diameter code	Thread ^a	E min	F	H	L	M min.	N	U	V	W min.	Lockwire diameter ^b
040	MJ4 × 0,7 – 4H6H	7,6	7	2,6	4,2	6,4	0	—	—	—	—
050	MJ5 × 0,8 – 4H6H	8,7	8	3,0	5,2	7,4	—	—	—	—	—
060	MJ6 × 1 – 4H5H	10,9	10	3,5	6,3	9,3	0,5	—	3,9	1,4	0,8
070	MJ7 × 1 – 4H5H	12,0	11	4,0	7,3	10,2	—	1,0	4,4	1,6	
080	MJ8 × 1 – 4H5H	14,3	13	—	8,3	12,2	—	—	5,0	—	—
100	MJ10 × 1,25 – 4H5H	18,9	17	5,0	10,3	16,0	—	—	6,9	2,1	—
120	MJ12 × 1,25 – 4H5H	21,1	19	6,0	12,3	18,0	—	—	8,0	2,6	—
140	MJ14 × 1,5 – 4H5H	24,5	22	7,0	14,4	21,0	0,6	—	9,6	3,1	1,25
160	MJ16 × 1,5 – 4H5H	26,8	24	8,0	16,4	23,0	—	1,5	10,7	3,6	
180	MJ18 × 1,5 – 4H5H	30,2	27	9,0	18,4	26,0	—	—	12,0	4,1	—
200	MJ20 × 1,5 – 4H5H	33,6	30	10,0	20,4	29,0	—	—	13,4	4,6	—
220	MJ22 × 1,5 – 4H5H	35,8	32	11,0	22,4	30,9	—	—	14,4	5,0	—
240	MJ24 × 2 – 4H5H	40,4	36	12,0	24,5	34,9	—	—	16,1	5,5	—

^a In accordance with ISO 5855-2.

^b For information, in conformity with ISO 245.