



## Standard Test Method for Determination of the Tendency of Lubricants to Promote Preignition in Two-Stroke-Cycle Gasoline Engines<sup>1</sup>

This standard is issued under the fixed designation D 4858; the number immediately following the designation indicates the year of original adoption or, in the case of revision, the year of last revision. A number in parentheses indicates the year of last reapproval. A superscript epsilon ( $\epsilon$ ) indicates an editorial change since the last revision or reapproval.

*This standard has been approved for use by agencies of the Department of Defense.*

### 1. Scope

1.1 This test method<sup>2</sup> evaluates the performance of lubricants intended for use in two-stroke-cycle spark-ignition gasoline engines which are prone to preignition.

1.2

1.2 The values stated in SI units are to be regarded as standard. No other units of measurement are included in this standard.

1.3 *This standard does not purport to address all of the safety concerns, if any, associated with its use. It is the responsibility of the user of this standard to establish appropriate safety and health practices and determine the applicability of regulatory limitations prior to use.*

~~1.3 The values stated in SI units are the standard. The values given in parentheses are provided for information only.~~

### 2. Referenced Documents

#### 2.1 ASTM Standards:<sup>3</sup>

B 152/B 152M Specification for Copper Sheet, Strip, Plate, and Rolled Bar

D 439 Specification for Automotive Gasoline<sup>4</sup>

D 445 Test Method for Kinematic Viscosity of Transparent and Opaque Liquids (and the Calculation of Dynamic Viscosity)

D 664 Test Method for Acid Number of Petroleum Products by Potentiometric Titration

D 874 Test Method for Sulfated Ash from Lubricating Oils and Additives

D 910 Specification for Aviation Gasolines

D 2270 Practice for Calculating Viscosity Index from Kinematic Viscosity at 40°C<sup>40</sup> and 100°C<sup>4100C</sup>

D 2699 Test Method for Research Octane Number of Spark-Ignition Engine Fuel

D 2700 Test Method for Motor Octane Number of Spark-Ignition Engine Fuel

D 2885 ~~Test Method for Research and Motor Method Octane Ratings Using On-Line Analyzers<sup>4</sup>~~ Test Method for Determination of Octane Number of Spark-Ignition Engine Fuels by On-Line Direct Comparison Technique<sup>5</sup>

D 2896 Test Method for Base Number of Petroleum Products by Potentiometric Perchloric Acid Titration

D 4857 Test Method for Determination of the Ability of Lubricants to Minimize Ring Sticking and Piston Deposits in Two-Stroke-Cycle Gasoline Engines Other than Than Outboards

D 4863 Test Method for Determination of Lubricity of Two-Stroke-Cycle Gasoline Engine Lubricants

E 230 Specification and Temperature-Electromotive Force (EMF) Tables for Standardized Thermocouples

#### 2.2 ANSI Standard:

ANSI MC 96.1 American National Standard for Temperature Measurement Thermocouples<sup>5</sup>

<sup>1</sup> This test method is under the jurisdiction of ASTM Committee D02 on Petroleum Products and Lubricants and is the direct responsibility of Subcommittee D02.B0.06 on Automotive Lubricants—Two-Stroke Cycle Gasoline.

Current edition approved Nov. 10, 2002; Dec. 1, 2008. Published January 2003/2009. Originally approved in 1988. Last previous edition approved in 2000/2002 as D 4858-002.

<sup>2</sup> Until the next revision of this test method, the ASTM Test Monitoring Center will update changes in this test method by means of Information Letters. These can be obtained from the ASTM Test Monitoring Center, 6555 Penn Ave., Pittsburgh, PA 15206-4489. Attention: Administrator. This edition incorporates revisions in all Information Letters through No. 01-3.

<sup>3</sup> For referenced ASTM standards, visit the ASTM website, [www.astm.org](http://www.astm.org), or contact ASTM Customer Service at [service@astm.org](mailto:service@astm.org). For *Annual Book of ASTM Standards* Vol 02.01, volume information, refer to the standard's Document Summary page on the ASTM website.

<sup>4</sup> Annual Book of ASTM Standards, Vol 05.01.

<sup>4</sup> Withdrawn. The last approved version of this historical standard is referenced on [www.astm.org](http://www.astm.org).

<sup>5</sup> Annual Book of ASTM Standards, Vol 05.02.

<sup>5</sup> Available from American National Standards Institute (ANSI), 25 W. 43rd St., 4th Floor, New York, NY 10036, <http://www.ansi.org>.

### 3. Terminology

#### 3.1 Definitions:

3.1.1 *combustion chamber*—in reciprocating internal combustion engines, the volume bounded by the piston crown and any portion of the cylinder walls extending above the piston crown when in the top dead center position, and the inner surface of the cylinder head including any spark plugs and other inserted components.

3.1.2 *preignition*—in a spark-ignition engine, ignition of the mixture of fuel and air in the combustion chamber before the passage of the spark.

3.1.3 *scuff, scuffing*—in lubrication, damage caused by instantaneous localized welding between surfaces in relative motion that does not result in immobilization of the parts. **D 4863**

3.1.4 *spark plug fouling*—deposition of essentially nonconducting material onto the electrodes of a spark plug that may, but will not necessarily, prevent the plug from operating. **D 4857**

3.1.5 *spark plug whiskering, also spark plug bridging*—a deposit of conductive material on the spark plug electrodes which tends to form a bridge between them, thus shorting out the plug. **D 4857**

#### 3.2 Definitions of Terms Specific to This Standard:

3.2.1 *major preignition*—preignition that causes a temperature increase of 10°C (18°F) or more measured at the inner surface of the cylinder head.

3.2.2 *minor preignition*—preignition that causes a temperature increase of more than 7°C (13°F) and less than 10°C (18°F) measured at the inner surface of the cylinder head.

### 4. Summary of Test Method

4.1 The test is run in a 49 cm<sup>3</sup> single-cylinder air-cooled engine operated under the conditions required by the specification against which it is being run. These are typically 4000  $\frac{\text{r}}{\text{min}}$  wide open throttle (WOT) using a 20:1 ratio of gasoline to oil by volume for a minimum of 50 h. The number of incidences of preignition, as indicated by a rapid increase in combustion chamber temperature, is recorded.

NOTE 1—*Pass-Fail Criterion*—The number of occurrences of preignition during the test of a candidate oil shall not exceed that permitted by the specification against which it is run.

### 5. Significance and Use

5.1 Two-stroke-cycle gasoline engines are generally more prone to preignition than are four-stroke-cycle engines due to the absence of the internal cooling that takes place during the induction stroke of the four-stroke-cycle engines. Preignition can lead to major piston damage, either directly due to localized overheating or as the result of preignition-induced detonation. Some lubricant additives that are widely used in four-stroke-cycle gasoline engine oils are known to increase the probability of preignition in gasoline two-stroke-cycle engines. This procedure is used to determine the tendency of an oil to induce preignition in both water-cooled and air-cooled two-stroke-cycle gasoline engines.

### 6. Apparatus

#### 6.1 Test Engine and Stand:

6.1.1 *Test Engine Configuration*—A Yamaha CE-50 49 cm<sup>3</sup> loop-scavenged air-cooled two-stroke-cycle engine is used.<sup>6</sup> This has 40 mm (1.57 in.) bore, 39.2 mm (1.54 in.) stroke, with an aluminum piston operating in a cast iron cylinder bore. The cylinder head is removable, with a hemispherical combustion chamber. For the purposes of this test the head shall be modified as specified in 6.3.1.1. Further details are given in Annex A1.

NOTE 2—The engine designation normally includes a final letter indicating the model, such as CE-50S, the model on which this test was developed. If this model is not available check the suitability for this test of available models with the manufacturer.<sup>6</sup>

6.1.2 *Test Stand*—The dynamometer shall be able to absorb 2.5 kW (3.4 hp) at 4000 to 6000  $\frac{\text{r}}{\text{min}}$  with an inherent torque measurement accuracy of  $\pm 0.5\%$  or better, and be capable of maintaining  $4000 \pm 30 \frac{\text{r}}{\text{min}}$  with varying power input. A direct shaft drive or a belt drive from the engine crankshaft may be used. A complete test stand assembly, as shown in Fig. 1, is available.<sup>7</sup>

6.1.3 *Cooling Blower*—The original internal engine fan shall be removed or have its blades machined off. A variable delivery blower with a free flow capacity of about 34 m<sup>3</sup>/min (1200 ft<sup>3</sup>/min) of air is recommended. The flow from the blower shall be directed toward the intake side of the engine. A suitable arrangement is shown in Fig. 1.

6.1.4 *Fuel System*—Fuel delivery pressure shall be maintained at 19 to 21 kPa (2.7 to 3.0 lb/in.<sup>2</sup>), kPa. The temperature of the fuel entering the carburetor shall not exceed 25°C (77°F), 25°C, and this may require cooling in hot climates.

<sup>6</sup> Annual Book of ASTM Standards, Vol 14.05.

<sup>6</sup> The sole source of supply of the apparatus known to the committee at this time is Engineering and Service Dept., Yamaha Motor Corp., 6555 Katella Ave Cypress, CA 90630. Parts, but not complete engines, may be obtained from Yamaha motorcycle dealers. If you are aware of alternative suppliers, please provide this information to ASTM International Headquarters. Your comments will receive careful consideration at a meeting of the responsible technical committee, which you may attend.

<sup>7</sup> Available from American National Standards Institute (ANSI), 25 W. 43rd St., 4th Floor, New York, NY 10036.

<sup>7</sup> Order from Southwest Research Institute, Automotive Products and Emissions Research Division, 6220 Culebra Rd., San Antonio, TX 78238-5166.

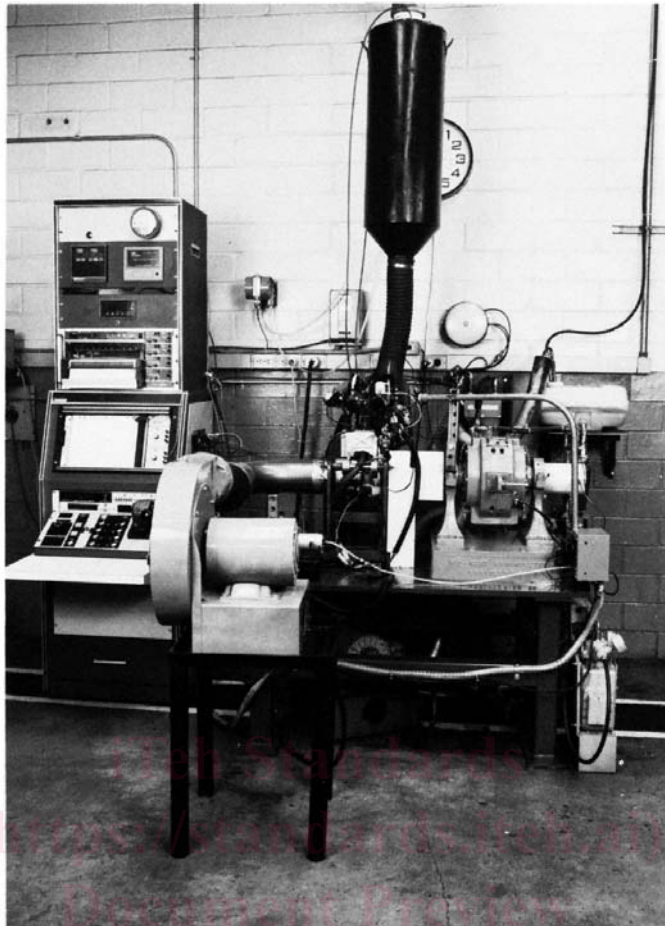

FIG. 1 Test Stand

6.2 Instrumentation:

6.2.1 Tachometer—An electronic tachometer accurate to  $\pm 25$  r/min. —An electronic tachometer accurate to  $\pm 25$  rpm.

6.2.2 Measurement of Ambient Conditions—6.2.2 is written on the assumption that the engine draws ambient air from the test room. If it is supplied with air from a controlled source, references to ambient temperature, pressure and humidity apply to the air from the controlled source.

6.2.2.1 Temperature—A thermocouple or thermometer shall be provided to read air temperature in the range 10 to 50°C (50 to 120°F)–50°C.

6.2.2.2 Barometric Pressure—A barometer recording the pressure in the test room is required.

6.2.2.3 Humidity—A hygrometer or a wet and dry bulb thermometer is also required.

6.2.2.4 Recorder—Continuous recording of the ambient conditions is recommended.

6.2.3 Calibration— Calibrate the tachometer, ambient temperature, and pressure measurement devices every 90 days. The calibration standard shall be traceable to NIST.

6.3 Engine and System Temperatures :

6.3.1 Combustion Chamber Temperature :

6.3.1.1 Modification of Cylinder Head— The cylinder head shall be fitted with a shielded thermocouple. A thermocouple of the iron-constantan type meeting the requirements of ANSI 91.6 Type J (summarized very briefly in Specification E 230) is recommended, but any thermocouple capable of performing satisfactorily under the conditions of the test can be used.<sup>8</sup> The general dimensions and machining requirements are shown in Fig. 2. The through hole, in which the thermocouple is required to fit closely, is about 3-mm (0.12-in.) diameter, and the counterbore shall not extend closer than 4 mm (0.16-in.) to the combustion chamber surface. The dimensions of the counterbore and thread are not critical, being suitable to available thermocouples, but the thread

<sup>8</sup> The sole source of supply of the apparatus known to the committee at this time is Engineering and Service Dept., Yamaha International Corp., P.O. Box 6555, Cypress, CA 90630. Parts, but not complete engines, may be obtained from Yamaha motorcycle dealers. If you are aware of alternative suppliers, please provide this information to ASTM International Headquarters. Your comments will receive careful consideration at a meeting of the responsible technical committee, which you may attend.

<sup>8</sup> A suitable instrument is available from Omega Engineering Inc., P.O. Box 4047, One Omega Dr., Stamford, CT 06907-0047.

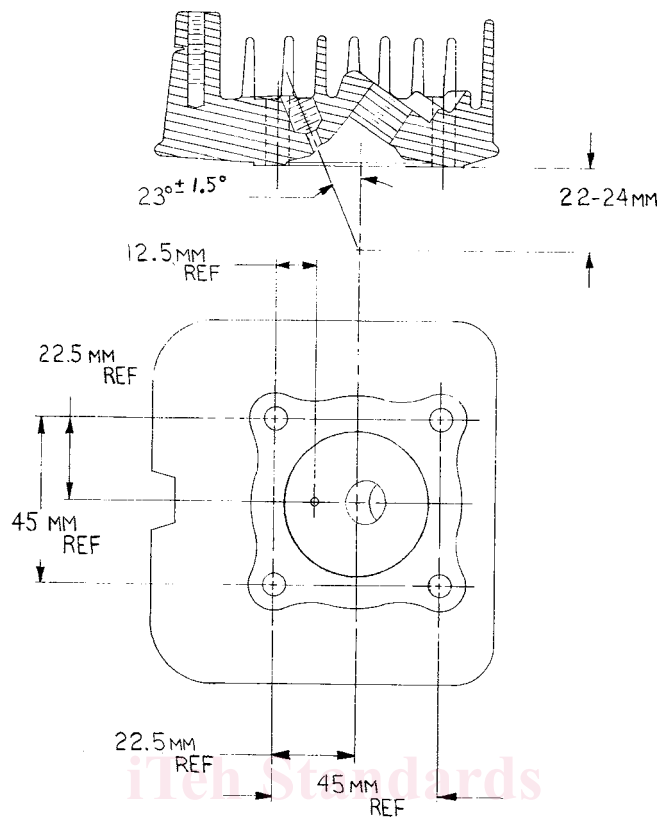

FIG. 2 Machining of Cylinder Head

diameter shall be less than 14 mm (0.55 in.). A 1/8 27-NPTF thread is recommended. The thermocouple shall be made so that the last 3 to 4 mm (0.12 to 0.16 in.) of its tip is a snug fit into the 3-mm diameter portion of the hole, and be mounted in the head so that its tip protrudes sufficiently to allow it to be ground flush with the internal surface of the head without penetrating the shield. When a head has been newly fitted with a thermocouple, run a break-in in accordance with 10.2 and Table 1. The thermocouple reading normally requires about 90 min to stabilize.

6.3.1.2 *Shutdown Provision*—Provision shall be made for shutdown of the engine in the case of a rapid (1 min or less) combustion chamber temperature increase of 10°C (18°F) or more. This normally indicates an incidence of *major preignition*, and is required to minimize the risk of damage to the engine. An automatic shut down when such an increase is experienced is recommended. At the least an alarm shall be provided to operate after a temperature increase of 6 to 7°C (11 to 13°F) to allow manual shut down by the operator if the 10°C limit is exceeded.

6.3.2 *Exhaust Temperature*—A thermocouple is required in the exhaust elbow within about 65 mm (2.5 in.) of the cylinder exhaust port to monitor exhaust temperature.<sup>7</sup> The thermocouple junction shall be located within ±3 mm (0.12 in.) of the center of the pipe.

6.3.3 *Spark Plug Gasket Temperature*—The spark plug gasket may be fitted with one or two thermocouples, the number depending on the instrumentation used. A design that has been found satisfactory is described in Appendix X1.<sup>9</sup>

6.3.4 *Combustion Chamber and Spark Plug Gasket Temperature Recorders*—These temperatures shall be recorded using a system capable of storing the data for later retrieval. Maximum interval between successive recordings of the combustion chamber temperature is 2 s. A system with a range from 40 to 750°C (100 to 1400°F) and an overall accuracy of ±2°C (4°F) is suitable.

6.3.5 *Calibration*—Calibrate the combustion chamber, exhaust and spark plug gasket temperature measurement devices every 90 days. The calibration standard shall be traceable to NIST.

#### 6.4 Fuel System:

6.4.1 *Flow Meter*—Any type accurate to ±0.01 kg/h (±0.02 lb/h) at about 1 kg/h (2 lb/h) flow rate may be used. Instruments measuring mass directly are preferred. If a volumetric measurement meter is used the temperature-density relationship shall be determined over the operating range for the actual fuel-non-reference oil mixture used for use in volume-mass conversion.

6.4.2 A temperature measuring device reading to at least 40°C (100°F) to an accuracy of ±1°C (2°F) and a pressure gauge or transducer reading up to about 35 kPa (5 lb/in.<sup>2</sup>) to an accuracy of ±2% are required to monitor the temperature and pressure of the fuel entering the carburetor.

<sup>9</sup> Order from Southwest Research Institute, Automotive Products and Emissions Research Division, 6220 Culebra Rd., San Antonio, TX 78238.

<sup>7</sup> A thermocouple basket that has been found satisfactory may be obtained from The Lewis Engineering Company, 238 Water St., Naugatuck, CT 06770.

**TABLE 1 Break-In**

Duration, min	RPM	Throttle Position	Plug Temperature, °C (°F)
2	2000 ± 100	Closed (idle)	Record
2	4000 ± 50	1/3 open	125 (257) max
2	4000 ± 50	1/3 open	125 max
2	5500 ± 50	1/3 open	125 (257) max
2	5500 ± 50	1/3 open	125 max
2	3500 ± 50	1/3 open	125 (257) max
2	3500 ± 50	1/3 open	125 max
2	4500 ± 50	1/3 open	125 (257) max
Repeat for a total of 2 cycles, or 20 min running time.			
Duration, min	RPM	Throttle Position	Plug Temperature, °C (°F)
Duration, min	RPM	Throttle Position	Plug Temperature, °C
2	2000 ± 100	Closed (idle)	Record
2	4000 ± 50	1/2 open	140 (284) max
2	4000 ± 50	1/2 open	140 max
2	5500 ± 50	1/2 open	140 (284) max
2	5500 ± 50	1/2 open	140 max
2	3500 ± 50	1/2 open	140 (284) max
2	4500 ± 50	1/2 open	140 (284) max
2	4500 ± 50	1/2 open	140 max
Repeat for a total of 4 cycles, or 40 min running time.			
Duration, min	RPM	Throttle Position	Plug Temperature, °C (°F)
Duration, min	RPM	Throttle Position	Plug Temperature, °C
2	2000 ± 100	Closed (idle)	Record
2	4000 ± 50	3/4 open	155 (311) max
2	4000 ± 50	3/4 open	155 max
2	5500 ± 50	3/4 open	155 (311) max
2	5500 ± 50	3/4 open	155 max
2	3500 ± 50	3/4 open	155 (311) max
2	3500 ± 50	3/4 open	155 max
2	4500 ± 50	3/4 open	155 (311) max
Repeat for a total of 4 cycles, or 40 min running time.			
Duration, min	RPM	Throttle Position	Plug Temperature, °C (°F)
Duration, min	RPM	Throttle Position	Plug Temperature, °C
2	2000 ± 100	Closed (idle)	Record
2	4000 ± 50	WOT	170 (338) max
2	4000 ± 50	WOT	170 max
2	5500 ± 50	WOT	170 (338) max
2	5500 ± 50	WOT	170 max
2	3500 ± 50	WOT	170 (338) max
2	3500 ± 50	WOT	170 max
2	4500 ± 50	WOT	170 (338) max
2	4500 ± 50	WOT	170 max
Repeat for a total of 2 cycles, or 20 min running time.			

## 7. Materials and Reagents

7.1 *Test Fuel*—The test fuel shall be a leaded gasoline consisting essentially of hydrocarbons, except for conventional lead antiknock, anticorrosion, anti-icing, etc. additives in normal concentration, and containing no non-lead metallic antiknock compounds or oxygenated blending compounds such as alcohols or ethers. It shall contain 0.4 to 0.6 g/L (1.5 to 2.2 g/gal) of lead as lead alkyls with conventional motor mix or aviation mix scavengers, and shall have a minimum motor octane number of 83, a maximum sensitivity (research octane number minus motor number) of 12 as determined by Test Methods ~~D2699, D2700, or D2885~~ D 2699, D 2700, or D 2885, as applicable, and shall otherwise meet the requirements of Specification D 439 volatility grade A or B. Aviation gasoline meeting these requirements and otherwise conforming to Specification D 910 Grade 100 or 100LL may

be used. Fuel from the same batch shall be used for calibration running and for any other tests referenced to that calibration. About 40 L (10 gal) of fuel are required for a test, plus 12 L (3 gal) for the break-in.

7.2 *Reference Oils*—ASTM 601 and 605 reference oils are used for calibration purposes.<sup>10</sup> ASTM 600 reference oil is used for break-in and as an assembly lubricant.<sup>10</sup> About 4 L (1 gal) of reference oil is required to run a calibration test, and 0.4 L (0.1 gal) of 600 for a break-in. The properties of these oils are summarized in Annex A2.

7.3 *Non-Reference Oil*—About 4 L (1 gal) are required for a 50 h test, varying according to the number of test hours specified. It is recommended that at least twice this amount be provided in case the test is rerun.

7.4 *Grease*—OMC needle bearing grease or petroleum jelly.

## 8. Calibration

8.1 After 30 tests or 180 days, whichever occurs first, or at any time a new or completely rebuilt engine or test bed is put in service, conduct calibration tests. Run a test for 50 h using reference oil 605. There shall be a minimum of four and a maximum of ten major preignitions during this test. If reference oil 605 fails to provide a minimum of four and a maximum of ten preignitions, investigate the cause and repeat the test. Run a test for 50 h using reference oil 601 as if it were a non-reference oil. When not more than one major preignition is obtained, no further action is required. If more than one preignition is obtained, investigate the cause and repeat the test.

8.2 In order for a test stand to be accepted for non-reference oil qualification, it shall be calibrated by the procedure of 8.1.

## 9. Procedure

9.1 *Assembly of the Engine:*

9.1.1 *Initial Build*—Use a new piston, rings, cylinder, and cylinder base and head gaskets (see Annex A3). The cylinder head is fitted with a thermocouple (see 6.3.1.1), and the compression ratio shall be checked as indicated in A3.6 through A3.8 after the thermocouple has been mounted, and corrected if necessary. This is done if possible by interchange of parts, but if necessary by modification as described in A3.9.

9.1.2 *Rebuild After Test*—It is not necessary to use new parts other than gaskets, a new piston and rings assembly and a new muffler, provided that all parts are clean and within specification with no sign of damage.

9.2 *Expected Life*—The cylinder will usually require replacement after 100 to 150 running hours. After about 1000 to 1500 running hours the entire engine will normally require replacement or a complete rebuild.

## 10. Operating Instructions

10.1 *Fuel Temperature and Pressure*—The temperature of the fuel entering the carburetor shall not exceed 25°C (77°F), 25°C, which may require cooling in hot climates, and fuel delivery pressure shall be maintained at 19 to 21 mPa (2.7 to 3.0 lb/in.<sup>2</sup>) kPa for all test operation.

10.2 *Break-In*—Before each test the engine shall be broken in for 2 h as specified in Table 1, using a 20:1 (5 % oil) by volume mixture of test gasoline and the (non-reference) or reference oil that is to be used in the test. After break-in the piston and cylinder shall be removed and examined. If there is any sign of piston scuff, ring sticking, or other malfunction the parts involved shall be replaced and the break-in repeated.

10.3 *Test Procedure:*

10.3.1 *Conditioning Run*—Following the break in, run the engine under the conditions of Table 2.

10.3.2 *Warmup*—When restarting after any shutdown run an 8 min warmup under the conditions of Table 3. This time is not counted toward the total test time.

10.3.3 *Test*—As soon as the warmup is completed, run the test for the time specified under the conditions of Table 4. The combustion chamber temperature shall be recorded continuously, the interval between successive readings not exceeding 2 s. This, together with the fuel pressure, fuel flow rate, and intake air temperature shall be logged every 30 min. The barometric pressure and the relative humidity in the test cell shall be recorded at least every 2 h. Set the automatic shut-down or alarm in accordance with 6.3.1.2, taking care to compensate for any gradual change in the temperature level that may occur. The exhaust temperature, while not a test parameter, shall be monitored as any change from the normal level for the installation and conditions of more than

<sup>9</sup> A suitable instrument is available from Omega Engineering Inc., P.O. Box 4047, One Omega Dr., Stamford, CT 06907.

<sup>10</sup> Available from ASTM Test Monitoring Center, 6555 Penn Ave., Pittsburgh, PA 15206-4489.

**TABLE 2 Conditioning Run**

Duration, min	Engine, rpm	Load	Plug Temperature, °C (°F)
30	4000 ± 30	0.746 ± .07 kw (1 ± 1 bhp)	174 ± 3°C (345 ± °F)
30	4000 ± 30	0.746 ± .07 kW	174 ± 3°C