Woodworking machines — Safety —
Part 6:
Single spindle vertical moulding
machines ("toupies")

Machines à bois — Sécurité —

Partie 6: Toupies monobroches à arbre vertical
iTeh STANDARD PREVIEW
(standards.iteh.ai)

[ISO 19085-6:2017](https://standards.iteh.ai/catalog/standards/sist/865ec3f1-4485-4dff-99ae-5729f31ad7fa/iso-19085-6-2017)

<https://standards.iteh.ai/catalog/standards/sist/865ec3f1-4485-4dff-99ae-5729f31ad7fa/iso-19085-6-2017>



iTeh STANDARD PREVIEW
(standards.iteh.ai)

ISO 19085-6:2017

<https://standards.iteh.ai/catalog/standards/sist/865ec3f1-4485-4dff-99ae-5729f31ad7fa/iso-19085-6-2017>



COPYRIGHT PROTECTED DOCUMENT

© ISO 2017, Published in Switzerland

All rights reserved. Unless otherwise specified, no part of this publication may be reproduced or utilized otherwise in any form or by any means, electronic or mechanical, including photocopying, or posting on the internet or an intranet, without prior written permission. Permission can be requested from either ISO at the address below or ISO's member body in the country of the requester.

ISO copyright office
Ch. de Blandonnet 8 • CP 401
CH-1214 Vernier, Geneva, Switzerland
Tel. +41 22 749 01 11
Fax +41 22 749 09 47
copyright@iso.org
www.iso.org

Contents

	Page
Foreword	vi
Introduction	vii
1 Scope	1
2 Normative references	2
3 Terms and definitions	2
4 List of significant hazards	8
5 Safety requirements and measures for controls	10
5.1 Safety and reliability of control systems.....	10
5.2 Control devices.....	10
5.3 Start.....	11
5.4 Safe stops.....	11
5.4.1 General.....	11
5.4.2 Normal stop.....	11
5.4.3 Operational stop.....	11
5.4.4 Emergency stop.....	11
5.5 Braking function of tool spindles.....	12
5.6 Mode selection.....	12
5.7 Spindle speed changing.....	12
5.7.1 Spindle speed changing by changing belts on the pulleys.....	12
5.7.2 Spindle speed changing by incremental speed change motor.....	12
5.7.3 Infinitely variable speed by frequency inverter.....	12
5.7.4 Spindle speed limiting device for tenoning.....	12
5.7.5 Changing of the direction of spindle rotation.....	12
5.8 Failure of any power supply.....	13
5.9 Manual reset control.....	13
5.10 Enabling control.....	13
5.11 Machine moving parts speed monitoring.....	13
5.12 Time delay.....	14
5.13 Power driven adjustment of arbor, demountable power feed unit, fences and table insert.....	14
6 Safety requirements and measures for protection against mechanical hazards	14
6.1 Stability.....	14
6.1.1 Stationary machines.....	14
6.1.2 Displaceable machines.....	14
6.2 Risk of break-up during operation.....	15
6.3 Tool holder and tool design.....	15
6.3.1 General.....	15
6.3.2 Spindle locking.....	17
6.3.3 Circular saw blade fixing device.....	18
6.3.4 Flange dimension for circular saw blades.....	18
6.3.5 Arbor rings.....	18
6.3.6 Quick tool/arbor change system.....	18
6.3.7 Manual adjustment of arbor height.....	18
6.3.8 Manual adjustment of arbor inclination.....	19
6.4 Braking.....	19
6.4.1 Braking of tool spindles.....	19
6.4.2 Maximum run-down time.....	19
6.4.3 Brake release.....	20
6.5 Safeguards.....	20
6.5.1 Fixed guards.....	20
6.5.2 Interlocking movable guards.....	20
6.5.3 Hold-to-run control.....	20

6.5.4	Two-hand control.....	20
6.5.5	Electro-sensitive protective equipment (ESPE).....	20
6.5.6	Pressure-sensitive protective equipment (PSPE).....	20
6.6	Prevention of access to moving parts.....	20
6.6.1	General.....	20
6.6.2	Guarding of tools.....	20
6.6.3	Guarding of drives.....	24
6.6.4	Guarding of shearing and/or crushing zones.....	24
6.7	Impact hazard.....	24
6.8	Clamping devices.....	24
6.9	Measures against ejection.....	25
6.9.1	General.....	25
6.9.2	Guards materials and characteristics.....	25
6.9.3	Anti-kickback devices.....	25
6.10	Work-piece supports and guides.....	27
6.10.1	Table.....	27
6.10.2	Work-piece guiding for straight work.....	30
6.10.3	Work-piece guiding for curved work.....	30
6.11	Safety appliances.....	31
7	Safety requirements and measures for protection against other hazards.....	32
7.1	Fire.....	32
7.2	Noise.....	32
7.2.1	Noise reduction at the design stage.....	32
7.2.2	Noise emission measurement.....	32
7.3	Emission of chips and dust.....	32
7.4	Electricity.....	33
7.4.1	General.....	33
7.4.2	Displaceable machines.....	33
7.5	Ergonomics and handling.....	33
7.6	Lighting.....	33
7.7	Pneumatics.....	33
7.8	Hydraulics.....	33
7.9	Electromagnetic compatibility.....	33
7.10	Laser.....	34
7.11	Static electricity.....	34
7.12	Errors of fitting.....	34
7.13	Isolation.....	34
7.14	Maintenance.....	34
8	Information for use.....	34
8.1	Warning devices.....	34
8.2	Marking.....	34
8.2.1	General.....	34
8.2.2	Additional markings.....	34
8.3	Instruction handbook.....	34
8.3.1	General.....	34
8.3.2	Additional information.....	34
	Annex A (informative) Performance level required.....	38
	Annex B (normative) Test for braking function.....	40
	Annex C (normative) Stability test for displaceable machines.....	41
	Annex D (normative) Impact test for guards.....	42
	Annex E (normative) Noise emission measurement for machines not in ISO 7960:1995.....	43
	Annex F (informative) Determination of maximum spindle speeds for single piece arbors.....	44
	Annex G (normative) Rigidity test for pressure pads, hand protectors and guiding steadies.....	48

iTeh STANDARD PREVIEW
(standards.iteh.ai)

[ISO 19085-6:2017](https://standards.iteh.ai/catalog/standards/sist/865ec3f1-4485-4dff-99ae-5729f31ad7fa/iso-19085-6-2017)

<https://standards.iteh.ai/catalog/standards/sist/865ec3f1-4485-4dff-99ae-5729f31ad7fa/iso-19085-6-2017>

Foreword

ISO (the International Organization for Standardization) is a worldwide federation of national standards bodies (ISO member bodies). The work of preparing International Standards is normally carried out through ISO technical committees. Each member body interested in a subject for which a technical committee has been established has the right to be represented on that committee. International organizations, governmental and non-governmental, in liaison with ISO, also take part in the work. ISO collaborates closely with the International Electrotechnical Commission (IEC) on all matters of electrotechnical standardization.

The procedures used to develop this document and those intended for its further maintenance are described in the ISO/IEC Directives, Part 1. In particular the different approval criteria needed for the different types of ISO documents should be noted. This document was drafted in accordance with the editorial rules of the ISO/IEC Directives, Part 2 (see www.iso.org/directives).

Attention is drawn to the possibility that some of the elements of this document may be the subject of patent rights. ISO shall not be held responsible for identifying any or all such patent rights. Details of any patent rights identified during the development of the document will be in the Introduction and/or on the ISO list of patent declarations received (see www.iso.org/patents).

Any trade name used in this document is information given for the convenience of users and does not constitute an endorsement.

For an explanation on the voluntary nature of standards, the meaning of ISO specific terms and expressions related to conformity assessment, as well as information about ISO's adherence to the World Trade Organization (WTO) principles in the Technical Barriers to Trade (TBT) see the following URL: www.iso.org/iso/foreword.html. (standards.iteh.ai)

This document was prepared by Technical Committee ISO/TC 39, *Machine tools*, Subcommittee SC 4 *Woodworking machines*. ISO 19085-6:2017

<https://standards.iteh.ai/catalog/standards/sist/865ec3f1-4485-4dff-99ae-5730611d7646/iso-19085-6>

This document is intended to be used in conjunction with ISO 19085-1:2017, which gives requirements common to different machine types.

A list of all parts in the ISO 19085 series can be found on the ISO website.

Introduction

The ISO 19085 series of International Standards provides technical safety requirements for the design and construction of woodworking machinery. It concerns designers, manufacturers, suppliers and importers of the machines specified in the Scope. It also includes a list of informative items that the manufacturer will need to give to the user.

This document is a type-C standard as stated in ISO 12100.

The machinery concerned and the extent to which hazards, hazardous situations or hazardous events are covered are indicated in the Scope of this document.

When requirements of this type-C standard are different from those which are stated in type-A or type-B standards, the requirements of this type-C standard take precedence over the requirements of the other standards for machines that have been designed and built according to the requirements of this type-C standard.

The full set of requirements for a particular type of woodworking machine are those given in the part of ISO 19085 applicable to that type, together with the relevant requirements from ISO 19085-1:2017, to the extent specified in the Scope of the applicable part of ISO 19085.

As far as possible, in parts of ISO 19085 other than ISO 19085-1:2017, safety requirements are referenced to the relevant sections of ISO 19085-1:2017, to avoid repetition and reduce their length. The other parts contain replacements and additions to the common requirements given in ISO 19085-1:2017.

Thus, [Clauses 5, 6, 7 and 8](#), with their subclauses and the annexes of this document, can either

- confirm as a whole,
- confirm with additions,
- exclude in total, or
- replace with specific text

the corresponding subclauses or annexes of ISO 19085-1:2017.

This interrelation is indicated in the first paragraph of each subclause or annex right after the title by one of the following statements:

- “This subclause of ISO 19085-1:2017 applies.”;
- “This subclause of ISO 19085-1:2017 applies with the following additions.”, or “This subclause of ISO 19085-1:2017 applies with the following additions, subdivided into further specific subclauses.”;
- “This subclause of ISO 19085-1:2017 does not apply.”;
- “This subclause of ISO 19085-1:2017 is replaced by the following text.”, or “This subclause of ISO 19085-1:2017 is replaced by the following text, subdivided into further specific subclauses.”.

Specific subclauses and annexes in this part of ISO 19085 without correspondent in ISO 19085-1:2017 are indicated by the introductory sentence: “Subclause (or annex) specific to this part of ISO 19085.”

[Clauses 1, 2, 4](#) replace the correspondent clauses of ISO 19085-1:2017, with no need for indication since they are specific to each part of the series.

NOTE Requirements for tools are given in EN 847-1:2013 and EN 847-2:2013.

iTeh STANDARD PREVIEW
(standards.iteh.ai)

[ISO 19085-6:2017](https://standards.iteh.ai/catalog/standards/sist/865ec3f1-4485-4dff-99ae-5729f31ad7fa/iso-19085-6-2017)

<https://standards.iteh.ai/catalog/standards/sist/865ec3f1-4485-4dff-99ae-5729f31ad7fa/iso-19085-6-2017>

Woodworking machines — Safety —

Part 6: Single spindle vertical moulding machines ("toupies")

1 Scope

This document gives the safety requirements and measures for stationary and displaceable hand-fed single spindle vertical moulding machines, hereinafter referred to as "machines", designed to cut wood and materials with similar physical characteristics to wood.

NOTE 1 For the definitions of stationary and displaceable machines, see ISO 19085-1:2017, 3.4 and 3.5.

It deals with all significant hazards, hazardous situations and events as listed in [Clause 4](#), relevant to the machines when they are operated, adjusted and maintained as intended and under the conditions foreseen by the manufacturer including reasonably foreseeable misuse. Also, transport, assembly, dismantling, disabling and scrapping phases are taken into account.

NOTE 2 For relevant but not significant hazards, e.g. sharp edges of the machine frame, see ISO 12100:2010.

It is also applicable to machines fitted with one or more of the following devices/additional working units, whose hazards have been dealt with:

- a) device for the arbor to be vertically adjustable relative to the table;
- b) device to tilt the arbor;
- c) device to fit a manually operated tenoning sliding table;
- d) glass bead saw unit;
- e) adjustable table insert;
- f) device for changing the direction of rotation of the spindle;
- g) device for fixing shank mounted tools on the arbor;
- h) interchangeable arbor;
- i) quick tool/arbor change system;
- j) demountable power feed unit;
- k) support for the demountable power feed unit with power driven adjustments.

This document does not apply to

- 1) machines equipped with outboard bearings,
- 2) machines equipped with powered movements of a front extension table and/or a tenoning sliding table, and
- 3) machines with an intended maximum tool diameter of less than or equal to 180 mm.

NOTE 3 Hand-held motor-operated electric tools are dealt with in IEC 60745-1 together with IEC 60745-2-17.

NOTE 4 Transportable motor-operated electric tools are dealt with in IEC 61029-1:1990, IEC 61029-2-8:1995/AMD1:1999 and IEC 61029-2-8:1995/AMD2:2001

This document is not applicable to machines intended for use in potentially explosive atmospheres or to machines manufactured prior to the date of its publication.

2 Normative references

The following documents are referred to in the text in such a way that some or all of their content constitutes requirements of this document. For dated references, only the edition cited applies. For undated references, the latest edition of the referenced document (including any amendments) applies.

ISO 7960:1995, *Airborne noise emitted by machine tools — Operating conditions for woodworking machines*

ISO 12100:2010, *Safety of machinery — General principles for design — Risk assessment and risk reduction*

ISO 13849-1:2015, *Safety of machinery — Safety-related parts of control systems — Part 1: General principles for design*

ISO 19085-1:2017, *Woodworking machines — Safety — Part 1: common requirements*

EN 847-1:2013, *Tools for woodworking — Safety requirements — Part 1: Milling tools, circular saw blades*

EN 847-2:2013, *Tools for woodworking — Safety requirements — Part 2: Requirements for shanks of shank mounted milling tools*

EN 847-3:2013, *Tools for woodworking — Safety requirements — Part 3: Clamping devices*

IEC 60204-1:2005, *Safety of machinery — Electrical equipment of machines — Part 1: General requirements*

IEC 61800-5-2:2007, *Adjustable speed electrical power drive systems — Part 5-2: Safety requirements — Functional*

ISO 19085-6:2017

<https://standards.iteh.ai/catalog/standards/sist/865ec3f1-4485-4dff-99ae-5729f31ad7fa/iso-19085-6-2017>

3 Terms and definitions

For the purposes of this document, the terms and definitions given in ISO 12100:2010, ISO 13849-1:2015, and ISO 19085-1:2017 and the following apply.

ISO and IEC maintain terminological databases for use in standardization at the following addresses:

- ISO Online browsing platform: available at <https://www.iso.org/obp>
- IEC Electropedia: available at <http://www.electropedia.org/>

3.1 single spindle vertical moulding machine

hand-fed machine fitted with a single vertical arbor (interchangeable or not interchangeable), which is fixed in position during the cutting operation and a horizontal table, which is fixed in total or in part during the cutting operation

Note 1 to entry: The arbor passes through the table and its drive is situated beneath the table.

Note 2 to entry: The main parts of the machine and their terminology are shown in [Figure 1](#).

Note 3 to entry: These machines are also known as shapers in the USA and toupie in Europe.

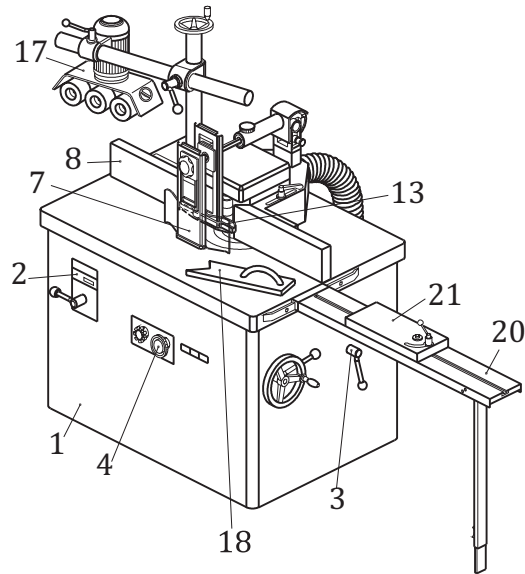

a) Example of a single spindle vertical moulding machine equipped for straight work

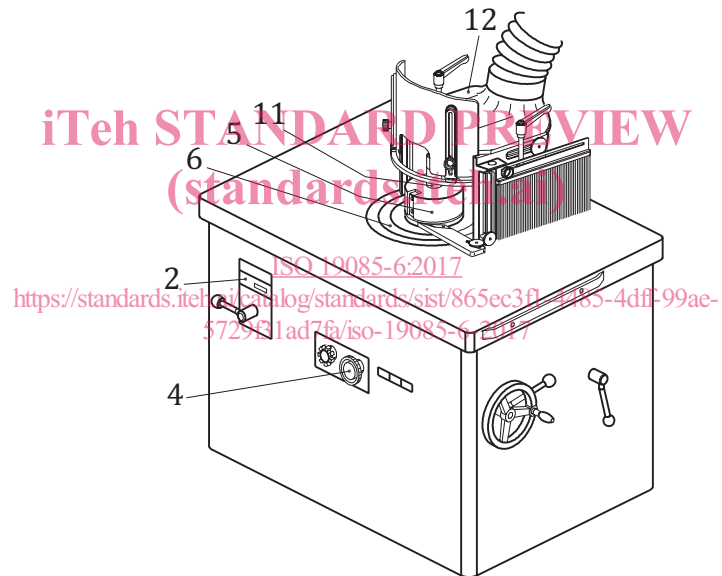

b) Example of a single spindle vertical moulding machine equipped for curved work

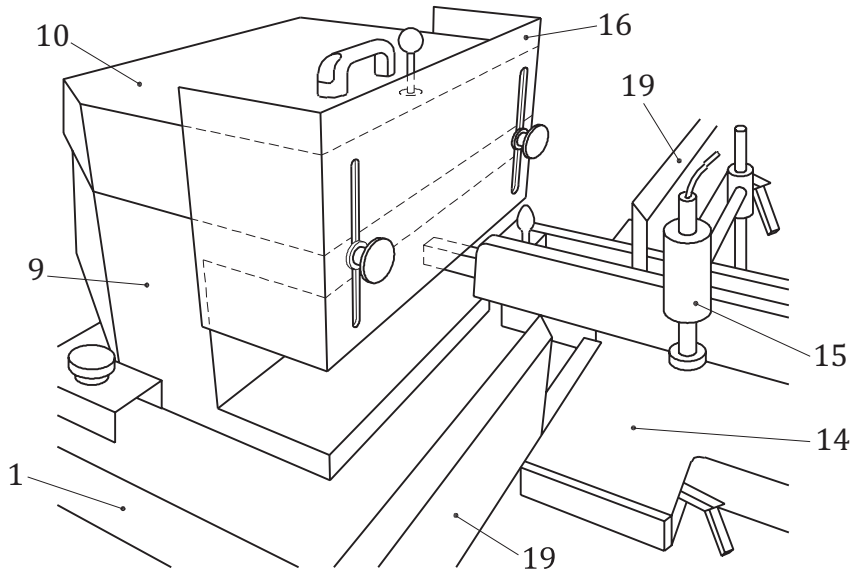

c) Example of a tool safeguard for tenoning with fixed and adjustable guards mounted on the machine and on the sliding table

Key

- | | |
|---|--------------------------------------|
| 1 main frame | 12 bonnet guard |
| 2 speed indicator | 13 table pressure pad |
| 3 spindle lock | 14 sliding table |
| 4 start and stop controls | 15 work-piece clamping device |
| 5 tool | 16 adjustable guard |
| 6 table rings | 17 de-mountable power feed unit |
| 7 fence pressure pad | 18 push stick |
| 8 fence plates connected to straight work guard | 19 guards fixed to the sliding table |
| 9 enclosure | 20 extension table |
| 10 hinged cover | 21 adjustable end stop |
| 11 curved work guard | |

iTeh STANDARD PREVIEW
(standards.iteh.ai)
ISO 19085-6:2017
<https://standards.iteh.ai/catalog/standards/sist/865ec3f1-4485-4dff-99ae-5729f31ad7fa/iso-19085-6-2017>

Figure 1 — Single spindle vertical moulding machine terminology

3.2

straight work

profiling or grooving of a work-piece with one face in contact with the table and a second with the fence, and where the work starts at one end of the work-piece and continues through to the other end

Note 1 to entry: See [Figures 1 a\)](#) and [2](#).

3.3

stopped straight work

machining of only a part of the work-piece length

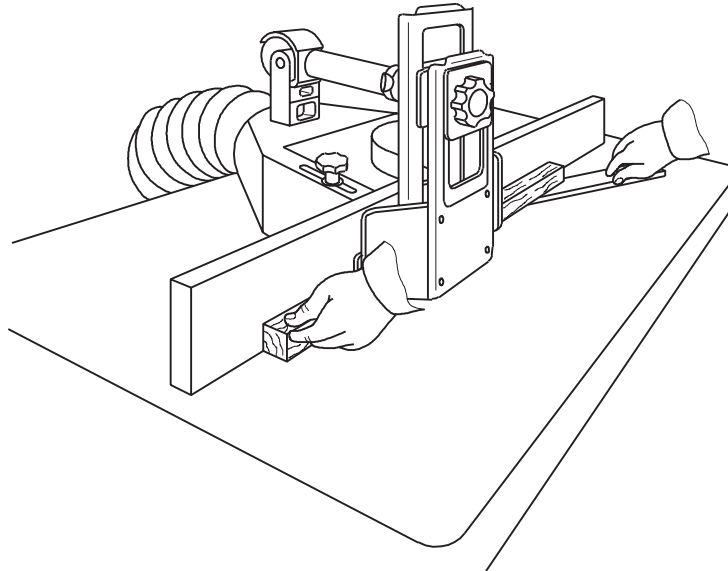

Figure 2 — Example of straight work

3.4 curved work

profiling or grooving of a curve on a work-piece by having one side in contact with the table (or if held in a jig with the jig in contact with the table) and the other in contact with the vertical reference of a steady or ball ring guide when using a jig (standards.iteh.ai)

Note 1 to entry: See [Figures 1 b\)](#) and [3](#).

ISO 19085-6:2017
<https://standards.iteh.ai/catalog/standards/sist/865e3f1-4485-4dff-99ae-5729b31ad7fa/iso-19085-6-2017>

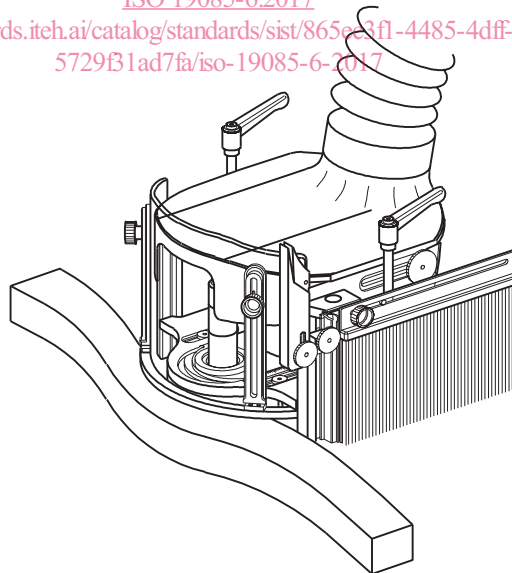
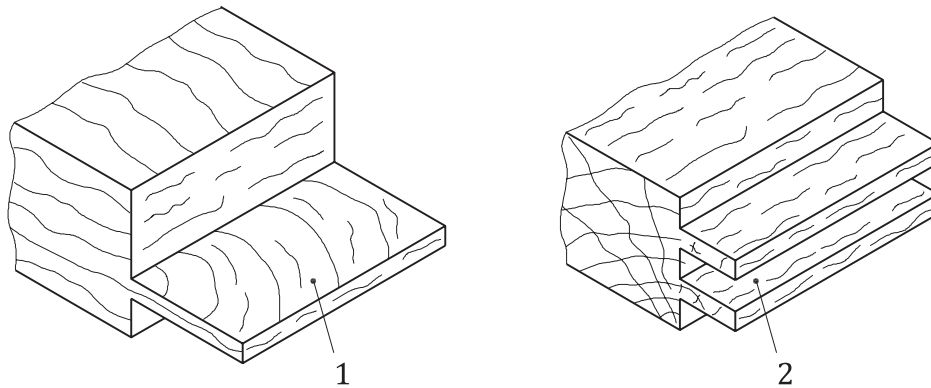

Figure 3 — Example of curved work

3.5 tenoning

machining of tenons and slots at the end of a work-piece to facilitate the joining of work-pieces

Note 1 to entry: See [Figures 1 c\)](#), [4](#) and [5](#).



Key

- 1 tenon
- 2 slot

Figure 4 — Example of work-piece with tenon/slot

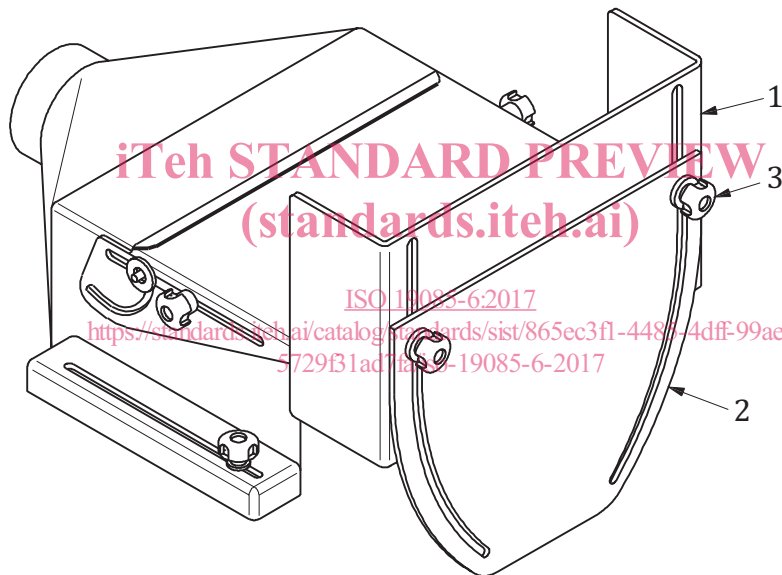

Key

- 1 manually adjustable guard
- 2 self-adjusting guard
- 3 device with double function: to adjust part no. 1 and to guide part no. 2

Figure 5 — Example of a tool safeguard for tenoning with manually and automatically adjustable guards

3.6 glass bead saw unit

work unit fitted with a saw blade to cut out a glass bead from the machined profile of the work-piece

Note 1 to entry: Example is given in [Figure 13](#).

3.7 single piece arbor

system where the arbor cannot be changed without dismounting the bearings

Note 1 to entry: See [Figure 6](#).

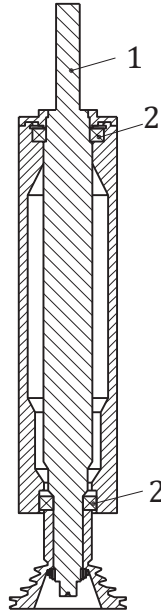
**Key**

- 1 arbor
- 2 bearings

Figure 6 — Examples of a single piece arbor
(standards.iteh.ai)

3.8**interchangeable arbor**

arbor, connected to the drive spindle, which can be changed either with (removable arbor) or without (quick change arbor) the aid of a tool

Note 1 to entry: See [Figures 7 a\)](#) and [b\)](#).

3.9**quick tool/arbor change system**

system for quick change of the arbor or of shank mounted tools without the aid of a tool

Note 1 to entry: See key 3 in [Figure 7 b\)](#).

Note 2 to entry: A pre-mounted combination of tool and arbor is called shank mounted tool (see EN 847-3:2013, Clause 1).