



Designation: D5568 – 08

Standard Test Method for Measuring Relative Complex Permittivity and Relative Magnetic Permeability of Solid Materials at Microwave Frequencies Using Waveguide¹

This standard is issued under the fixed designation D5568; the number immediately following the designation indicates the year of original adoption or, in the case of revision, the year of last revision. A number in parentheses indicates the year of last reapproval. A superscript epsilon (ϵ) indicates an editorial change since the last revision or reapproval.

1. Scope*

1.1 This test method covers a procedure for determining relative complex permittivity (relative dielectric constant and loss) and relative magnetic permeability of isotropic, reciprocal (non-gyromagnetic) solid materials. If the material is nonmagnetic, it is acceptable to use this procedure to measure permittivity only.

1.2 This measurement method is valid over a frequency range of approximately 100 MHz to over 20 GHz. These limits are not exact and depend on the size of the specimen, the size of rectangular waveguide transmission line used as a specimen holder, and on the applicable frequency range of the network analyzer used to make measurements. The practical lower and upper frequencies are limited by specimen dimension requirements (large specimens at low frequencies and small specimens at high frequencies). Being a non-resonant method, the selection of any number of discrete measurement frequencies in a measurement band would be suitable. Use of multiple rectangular waveguide transmission line sizes are required to cover this entire frequency range (100 MHz to 20 GHz). This test method can also be generally applied to circular waveguide test fixtures. The rectangular waveguide fixture is preferred over coaxial fixtures when samples have in-plane anisotropy or are difficult to manufacture precisely.

1.3 The values stated in SI units are to be regarded as the standard. The values given in parentheses are in English units. The equations shown here assume an $e^{+j\omega t}$ harmonic time convention.

1.4 *This standard does not purport to address all of the safety concerns, if any, associated with its use. It is the responsibility of the user of this standard to establish appropriate safety and health practices and determine the applicability of regulatory limitations prior to use.*

¹ This test method is under the jurisdiction of ASTM Committee D09 on Electrical and Electronic Insulating Materials and is the direct responsibility of Subcommittee D09.12 on Electrical Tests.

Current edition approved Dec. 15, 2008. Published January 2009. Originally approved in 1994. Last previous edition approved in 2001 as D5568 – 01. DOI: 10.1520/D5568-08.

2. Referenced Documents

2.1 *ASTM Standards:*²

D1711 *Terminology Relating to Electrical Insulation*

3. Terminology

3.1 For other definitions used in this test method, refer to Terminology D1711.

3.2 *Definitions:*

3.2.1 *relative complex permittivity (relative complex dielectric constant), ϵ_r^* , n* —the proportionality factor that relates the electric field to the electric flux density, and which depends on intrinsic material properties such as molecular polarizability, charge mobility, etc.:

$$\epsilon_r^* = \epsilon_r' - j\epsilon_r'' = \frac{\vec{D}}{\epsilon_0 \vec{E}} \quad (1)$$

where:

ϵ_0 = the permittivity of free space,

\vec{D} = the electric flux density vector, and

\vec{E} = the electric field vector.

3.2.1.1 *Discussion*—In common usage the word “relative” is frequently dropped. The real part of complex relative permittivity (ϵ_r') is often referred to as simply relative permittivity, permittivity or dielectric constant. The imaginary part of complex relative permittivity (ϵ_r'') is often referred to as the loss factor. In anisotropic media, permittivity is described by a three dimensional tensor.

3.2.1.2 *Discussion*—For the purposes of this test method, the media is considered to be isotropic, and therefore permittivity is a single complex number at each frequency.

3.2.2 *relative complex permeability, μ_r^* , n* —the proportionality factor that relates the magnetic flux density to the magnetic field, and which depends on intrinsic material properties such as magnetic moment, domain magnetization, etc.:

² For referenced ASTM standards, visit the ASTM website, www.astm.org, or contact ASTM Customer Service at service@astm.org. For *Annual Book of ASTM Standards* volume information, refer to the standard's Document Summary page on the ASTM website.

*A Summary of Changes section appears at the end of this standard

$$\mu_r^* = \mu_r' - j\mu_r'' = \frac{\vec{B}}{\mu_0 \vec{H}} \quad (2)$$

where:

μ_0 = the permeability of free space,

\vec{B} = the magnetic flux density vector, and

\vec{H} = the magnetic field vector.

3.2.2.1 Discussion—In common usage the word “relative” is frequently dropped. The real part of complex relative permeability (μ_r') is often referred to as relative permeability or simply permeability. The imaginary part of complex relative permeability (μ_r'') is often referred to as the magnetic loss factor. In anisotropic media, permeability is described by a three dimensional tensor.

3.2.2.2 Discussion—For the purposes of this test method, the media is considered to be isotropic, and therefore permeability is a single complex number at each frequency.

3.3 Definitions of Terms Specific to This Standard:

3.3.1 A list of symbols specific to this test method is given in **Annex A1**.

3.3.2 calibration, n —a procedure for connecting characterized standard devices to the test ports of a network analyzer to characterize the measurement system’s systematic errors. The effects of the systematic errors are then mathematically removed from the indicated measurements. The calibration also establishes the mathematical reference plane for the measurement test ports.

3.3.2.1 Discussion—Modern network analyzers have this capability built in. There are a variety of calibration kits that can be used depending on the type of test port. The models used to predict the measurement response of the calibration devices depends on the type of calibration kit. Most calibration kits come with media that can be used to load the definitions of the calibration devices into the network analyzer. Calibration kit definitions loaded into the network analyzer must match the devices used to calibrate. Since both transmission and reflection measurements are used in this standard, a two-port calibration is required.

3.3.3 network analyzer, n —a system that measures the two-port transmission and one-port reflection characteristics of a multiport system in its linear range and at a common input and output frequency.

3.3.3.1 Discussion—For the purposes of this standard, this description includes only those systems that have a synthesized signal generator, and that measure the complex scattering parameters (both magnitude and phase) in the forward and reverse directions of a two-port network (S_{11} , S_{21} , S_{12} , S_{22}).

3.3.4 scattering parameter (S -parameter), S_{ij} , n —a complex number consisting of either the reflection or transmission coefficient of a component at a specified set of input and output reference planes with an incident signal on only a single port.

3.3.4.1 Discussion—As most commonly used, these coefficients represent the quotient of the complex electric field strength (or voltage) of a reflected or transmitted wave divided by that of an incident wave. The subscripts i and j of a typical coefficient S_{ij} refer to the output and input ports, respectively.

For example, the forward transmission coefficient S_{21} is the ratio of the transmitted wave voltage at Reference Plane 2 (Port 2) divided by the incident wave voltage measured at Reference Plane 1 (Port 1). Similarly, the Port 1 reflection coefficient S_{11} is the ratio of the Port 1 reflected wave voltage divided by the Port 1 incident wave voltage at reference plane 1 (Port 1).

3.3.5 transverse electric (TE_{mn}) wave, n —an electromagnetic wave in which the electric field is everywhere perpendicular to the direction of propagation.

3.3.5.1 Discussion—The index m is the number of half-period variations of the field along the waveguide’s larger transverse dimension, and n is the number of half-period variations of the field along the waveguide’s smaller transverse dimension. The dominant wave in a rectangular waveguide is TE_{10} . The electric field lines of the TE_{10} mode are parallel to the shorter side.

3.3.6 cutoff frequency, n —the lowest frequency at which non-evanescent, dominant mode propagation can occur within a rectangular waveguide.

4. Summary of Test Method

4.1 A carefully machined test specimen is placed in an electromagnetic waveguide transmission line and connected to a calibrated network analyzer that is used to measure the S -parameters of the transmission line-with-specimen. A specified data-reduction algorithm is then used to calculate permittivity and permeability. If the material is nonmagnetic a different algorithm is used to calculate permittivity only. Error corrections are then applied to compensate for air gaps between the specimen and the transmission line conductor surfaces.

5. Significance and Use

5.1 Design calculations for radio frequency (RF), microwave and millimetre-wave components require the knowledge of values of complex permittivity and permeability at operating frequencies. This test method is useful for evaluating small experimental batch or continuous production materials used in electromagnetic applications. Use this method to determine complex permittivity only (in non-magnetic materials) or both complex permittivity and permeability simultaneously.

6. Interferences

6.1 The upper limits of permittivity and permeability that can be measured using this test method are restricted by the transmission line and specimen geometries, which can lead to unwanted higher order waveguide modes. In addition, excessive electromagnetic attenuation due to a high loss factor within the test specimen can prevent determination of permittivity and permeability. No specific limits are given in this standard, but this test method is practically limited to low-to-medium values of permittivity and permeability.

6.2 The existence of air gaps between the test specimen and the transmission line introduces a negative bias into measurements of permittivity and permeability. In this test method compensation for this bias is required, and to do so requires knowledge of the air gap sizes. Air gap sizes are estimated from dimensional measurements of the specimen and the

specimen holder, which can be measured with micrometers, feeler gauges, or other precision instruments. Several different error correction models have been developed, and a frequency independent series capacitor model is described in Annex A2. Air gap corrections are only approximate and therefore this test method is practically limited to low-to-medium values of permittivity and permeability.

7. Apparatus

7.1 *Experimental Test Fixture*—The test fixture includes a specimen holder connected to a network analyzer, as shown in Fig. 1.

7.2 *Network Analyzer*—The network analyzer needs a full 2-port test set that can measure transmission and reflection scattering parameters. Use a network analyzer that has a synthesized signal generator in order to ensure good frequency stability and signal purity.

7.3 *Waveguide Calibration Kit*—To define Port 1 and Port 2 measurement reference planes, calibration of the waveguide test fixture is required. A calibration kit consists of well-characterized standard devices and mathematical models of those devices. Use a through-reflect-line (TRL), an open-short-load-through (OSLT), or any other calibration kit that yields similar calibration quality to calibrate the waveguide test fixture.

7.4 *Specimen Holder:*

7.4.1 Because parameters such as specimen holder length and cross-sectional dimensions are of critical importance to the calculation of permittivity and permeability, carefully measure and characterize the physical dimensions of the specimen holder.

7.4.2 If a separate length of transmission line is used to hold the specimen, ensure that that empty length of line is also in place during calibration of the specimen holder.

7.4.3 The theoretical model used for this test method assumes that only the dominant mode of propagation exists (TE_{10} for rectangular waveguide or TE_{11} for circular waveguide). The existence of higher-order modes restricts the measurable bandwidth for a given waveguide test fixture.

7.4.4 Be sure that the specimen holder dimensions are within proper tolerances for the waveguide transmission line size in use. For an X-band rectangular waveguide transmission line the dimensions of the inner opening are denoted by “a” the width and “b” the height. Proper tolerances are then:

X-band waveguide width:

$$a = 22.86 \pm 0.10 \text{ mm } (0.900 \pm 0.004 \text{ in.}) \tag{3}$$

X-band waveguide height:

$$b = 10.16 \pm 0.10 \text{ mm } (0.900 \pm 0.004 \text{ in.}) \tag{4}$$

7.4.4.1 Dimensions and tolerances of other standard waveguides are in the appropriate manufacturer’s specifications and U.S. military specifications.³

8. Test Specimen

8.1 Make the test specimen long enough to ensure good alignment inside the holder. Also, make the test specimen long enough to ensure that the phase shift through the specimen is much greater than the phase measurement uncertainty of the network analyzer at the lowest measurement frequency. If a specimen is expected to have low loss, sufficient length is also required to ensure accurate determination of the loss factor. Finally, for high loss specimens, the specimen length cannot be so long that high insertion loss prevents material property inversion.

8.2 Accurately machine the specimen so that its dimensions minimize the air gap that exists between the conductor surfaces

³ MIL-DTL-85/1F, 20 November 1998.

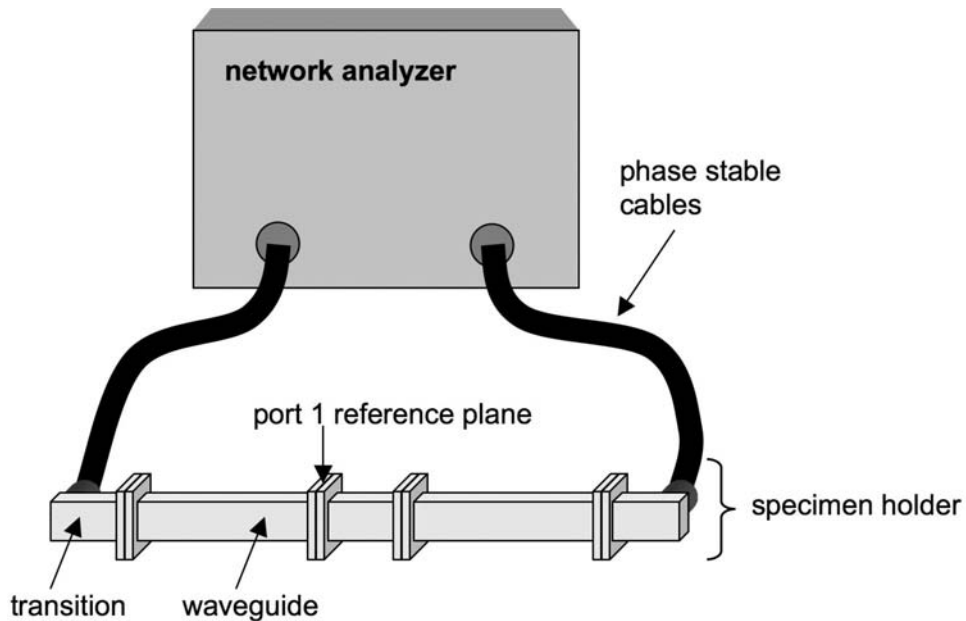

FIG. 1 Diagram of Experimental Fixture

and the specimen. In this respect, measure the specimen holder's dimensions in order to specify the tightest tolerances possible for specimen preparation. Keep physical variations of specimen dimensions as small as is practicable and include specimen dimensions and uncertainties in the report.

9. Preparation of Apparatus

9.1 *Inspect Network Analyzer Test Ports*—Insure that the recession of both test ports' center conductor shoulder behind the outer conductor mating plane meets the minimum specifications. Refer to network analyzer manufacturer's documentation to provide connector specifications.

9.2 *Flexing and Tightening Cables and Connectors*—Cable flexing and improperly tightened connectors introduce phase and magnitude errors into S-parameter data. For this reason, bend the test cables as little as possible, and under no circumstances bend the test cables smaller than the manufacturer's minimum recommended radius. Use of phase-stable cables is highly recommended. Insofar as possible, return the network analyzer cables to the same position during measurement of calibration standards and specimen. Use a torque wrench with the manufacturer's recommended torque to tighten connectors.

9.3 *Inspect and Clean Specimen, Specimen Holder, and Connectors*—If contamination is a concern, handle specimens with laboratory gloves. Clean specimens, connectors, and transmission lines using lint-free swabs and isopropyl alcohol (not less than 99 % pure). Blow out specimens, connectors, and transmission lines using filtered, pressurized air (not breath). Examine specimens for cracks and chips on their edges. Note any damage to specimens.

9.4 Network Analyzer Setup:

9.4.1 Turn on the network analyzer before beginning calibration and measurements. Refer to manufacturer documentation for minimum warm-up period.

9.4.2 Put network analyzer into step frequency mode. Set the start frequency and stop frequency as desired. Set the number of measurement points to the desired value.

9.4.3 If available, set the network analyzer's variable intermediate frequency (IF) bandwidth to less than 30 Hz, otherwise set the network analyzer data-averaging factor to a value >200 .

9.4.4 Perform a two-port test fixture calibration using a waveguide calibration kit in accordance with the manufacturer's procedures and in accordance with 7.3.

10. Procedure

10.1 The following procedure applies to rectangular and circular waveguide.

10.2 Calibration Verification:

10.2.1 Insert a known verification specimen, such as cross-linked polystyrene or polytetrafluoroethylene into the waveguide so that the front surface is flush with the Port 1 reference plane.

10.2.2 Connect the waveguide flanges back together to their original configuration.

10.2.3 Make sure that the position of the waveguide feed cables are as close to the same as when the calibration was done, so that phase errors from cable movement are minimized.

10.2.4 Measure the scattering parameters of the specimen holder with verification specimen. The necessary scattering parameters depend on the calculation procedure used to determine intrinsic properties (refer to Section 11).

10.2.5 Calculate the intrinsic properties of the verification specimen from the measured scattering parameters, as described in the section on calculation. If the calculated intrinsic properties are incorrect, check the waveguide fixture to make sure connectors are properly tightened and that there is nothing wrong with the feed cables. Also check to make sure the calibration was done correctly and the inversion algorithm and phase correction were properly applied.

10.3 Specimen Measurement:

10.3.1 Measure and record the dimensions of the specimen with a micrometer or other precision instrument.

10.3.2 Insert the unknown specimen into the Port 1 side of the specimen holder, as shown in Fig. 2. Be careful not to

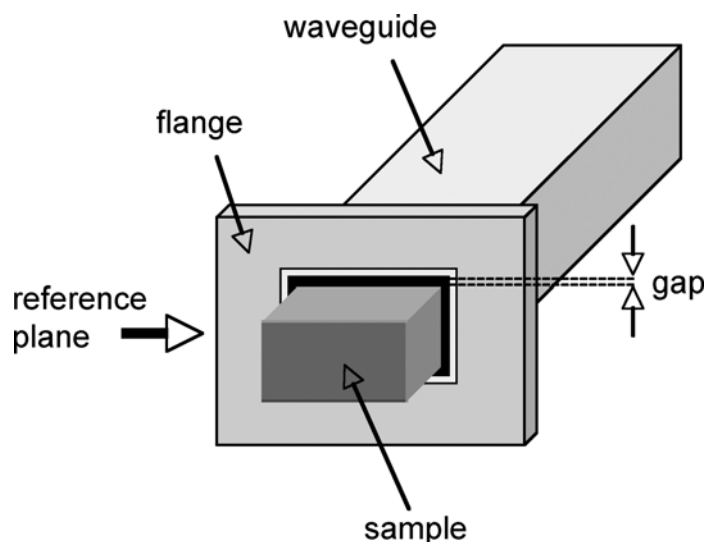

FIG. 2 Drawing of Sample Being Inserted into Waveguide