**Petroleum products — Determination
of the filterability of lubricating oils —
Part 1:
Procedure for oils in the presence of
water**

iTeh STANDARD PREVIEW
*Produits pétroliers — Détermination de la filtrabilité des huiles
lubrifiantes —
(standards.iteh.ai)
Partie 1: Méthode pour les huiles en présence d'eau*

ISO 13357-1:2017

<https://standards.iteh.ai/catalog/standards/sist/ef3bfd32-20b5-4644-a458-9d35c60a9b6d/iso-13357-1-2017>



iTeh STANDARD PREVIEW
(standards.iteh.ai)

ISO 13357-1:2017

<https://standards.iteh.ai/catalog/standards/sist/ef3bfd32-20b5-4644-a458-9d35c60a9b6d/iso-13357-1-2017>



COPYRIGHT PROTECTED DOCUMENT

© ISO 2017, Published in Switzerland

All rights reserved. Unless otherwise specified, no part of this publication may be reproduced or utilized otherwise in any form or by any means, electronic or mechanical, including photocopying, or posting on the internet or an intranet, without prior written permission. Permission can be requested from either ISO at the address below or ISO's member body in the country of the requester.

ISO copyright office
Ch. de Blandonnet 8 • CP 401
CH-1214 Vernier, Geneva, Switzerland
Tel. +41 22 749 01 11
Fax +41 22 749 09 47
copyright@iso.org
www.iso.org

Contents

	Page
Foreword.....	iv
Introduction.....	v
1 Scope.....	1
2 Normative references.....	1
3 Terms and definitions.....	2
4 Principle.....	2
5 Reagents and materials.....	2
6 Apparatus.....	3
7 Samples and sampling.....	5
8 Preparation of apparatus.....	5
9 Procedure.....	6
10 Calculations.....	8
10.1 Stage I filterability.....	8
10.2 Stage II filterability.....	8
11 Expression of results.....	8
11.1 General.....	8
11.2 Assessment of validity.....	8
12 Precision.....	9
13 Test report.....	9
Annex A (informative) Suitable procedure for the addition of graduations to a measuring cylinder.....	10
Bibliography.....	12

Foreword

ISO (the International Organization for Standardization) is a worldwide federation of national standards bodies (ISO member bodies). The work of preparing International Standards is normally carried out through ISO technical committees. Each member body interested in a subject for which a technical committee has been established has the right to be represented on that committee. International organizations, governmental and non-governmental, in liaison with ISO, also take part in the work. ISO collaborates closely with the International Electrotechnical Commission (IEC) on all matters of electrotechnical standardization.

The procedures used to develop this document and those intended for its further maintenance are described in the ISO/IEC Directives, Part 1. In particular the different approval criteria needed for the different types of ISO documents should be noted. This document was drafted in accordance with the editorial rules of the ISO/IEC Directives, Part 2 (see www.iso.org/directives).

Attention is drawn to the possibility that some of the elements of this document may be the subject of patent rights. ISO shall not be held responsible for identifying any or all such patent rights. Details of any patent rights identified during the development of the document will be in the Introduction and/or on the ISO list of patent declarations received (see www.iso.org/patents).

Any trade name used in this document is information given for the convenience of users and does not constitute an endorsement.

For an explanation on the voluntary nature of standards, the meaning of ISO specific terms and expressions related to conformity assessment, as well as information about ISO's adherence to the World Trade Organization (WTO) principles in the Technical Barriers to Trade (TBT) see the following URL: www.iso.org/iso/foreword.html. (standards.iteh.ai)

The committee responsible for this document is ISO/TC 28, *Petroleum and related products: fuels and lubricants from natural or synthetic sources*. [ISO 13357-1:2017](https://standards.iteh.ai/catalog/standards/sist/ef3bfd32-20b5-4644-a458-9125f1380bd1/iso-13357-1:2017)

This second edition cancels and replaces the first edition (ISO 13357-1:2002), of which it constitutes a minor revision including alternative membranes in order to enable the continued use of this document.

A list of all parts in the ISO 13357 series can be found on the ISO website.

Introduction

As the fluid in a hydraulic system acts as a lubricant to minimize wear of the components, it is important to reduce the concentrations of circulating hard contaminant particles. This is particularly necessary when the performance of the system depends on the maintenance of small clearances and orifices. Removal of these contaminants is effected by the use of filters. The ability of a hydraulic fluid to pass through fine filters, without plugging them, is called its “filterability”. This document describes a laboratory test procedure for assessing the filterability of mineral oils which have been heat-soaked in the presence of water. Filterability so determined is not a physical characteristic of the oil, but represents an estimation of its behaviour in service.

This document describes two measurements, referred to as “stages”. The Stage I determination is based on a comparison of the mean flow rate of a fluid through a test membrane with its initial flow rate. Oils having good Stage I filterability, but only a poor Stage II performance (see below), would be unlikely to give performance problems in use, unless extremely fine system filters are utilized.

The Stage II determination is based upon the ratio between the initial flow rate of fluid through the test membrane and the rate at the end of the test. It is considered that this part of the procedure is a more severe test, and is more sensitive to the presence of gels and fine silts in the oil. Silts and gels may be present in an oil when it is produced, or could be formed as an oil ages, especially when hot. An oil with good Stage II filterability would be unlikely to give filtration problems even in the most extreme conditions, and with fine (less than 5 µm) filtration present. It would thus be suitable for use in more critical hydraulic and lubrication systems.

The procedure has been evaluated with mineral oils up to ISO viscosity grade 100. There would appear to be no reason why it should not be used with oils of higher viscosity grade (ISO viscosity grade 220 is a practical maximum), but the data obtained could not be claimed to be completely in accordance with this method. Similarly, it should be possible to extend the test procedure to fluids other than mineral oils. However, some fluids, e.g. fire-resistant fluids, will not be compatible with the specified test membranes, and the test could only be used for comparison purposes even when suitable membranes, with similar pore size/pore density characteristics to those specified in this procedure, have been identified.

iTeh STANDARD PREVIEW
(standards.iteh.ai)

ISO 13357-1:2017

<https://standards.iteh.ai/catalog/standards/sist/ef3bfd32-20b5-4644-a458-9d35c60a9b6d/iso-13357-1-2017>

Petroleum products — Determination of the filterability of lubricating oils —

Part 1: Procedure for oils in the presence of water

WARNING — The use of this document can involve hazardous materials, operations and equipment. This document does not purport to address all of the safety problems associated with its use. It is the responsibility of the user of this document to establish appropriate safety and health practices and determine the applicability of regulatory limitations prior to use.

1 Scope

This document specifies a procedure for the evaluation of the filterability of lubricating oils, particularly those designed for hydraulic applications, in the presence of water. The procedure only applies to mineral-based oils, since fluids manufactured from other materials (e.g. fire-resistant fluids) may not be compatible with the specified test membranes. The range of application has been evaluated with oils of viscosity up to ISO viscosity grade (VG) 100, as defined in ISO 3448. Within the range described, the filterability as defined is not dependent on the viscosity of the oil. The procedure is not suitable for some hydraulic oils on which specific properties have been conferred by the use of insoluble/partially soluble additives, or by particularly large molecular species.

NOTE Filterability is a prime requirement for lubricating oils used in hydraulic systems because of the fine filters used in this application.

This document defines a method for assessing the filterability of oils in the presence of contaminating water. It is noted that some oils will exhibit poorer filterability characteristics in these conditions. ISO 13357-2^[1] is used to investigate the filterability of an oil which is used in applications where the presence of water in the oil is unlikely. An oil which has good filterability in the presence of contaminating water will not necessarily have equally good filterability in dry conditions. An oil having good filterability only when wet is unlikely to be generally acceptable.

2 Normative references

The following documents are referred to in the text in such a way that some or all of their content constitutes requirements of this document. For dated references, only the edition cited applies. For undated references, the latest edition of the referenced document (including any amendments) applies.

ISO 1219-1, *Fluid power systems and components — Graphical symbols and circuit diagrams — Part 1: Graphical symbols for conventional use and data-processing applications*

ISO 3170, *Petroleum liquids — Manual sampling*

ISO 3448, *Industrial liquid lubricants — ISO viscosity classification*

ISO 3696, *Water for analytical laboratory use — Specification and test methods*

ISO 4788, *Laboratory glassware — Graduated measuring cylinders*

ISO 6614:1994, *Petroleum products — Determination of water separability of petroleum oils and synthetic fluids*

3 Terms and definitions

For the purposes of this document, the following terms and definitions apply.

ISO and IEC maintain terminological databases for use in standardization at the following addresses:

- IEC Electropedia: available at <http://www.electropedia.org/>
- ISO Online browsing platform: available at <http://www.iso.org/obp>

3.1 filterability

dimensionless number which is the ratio, expressed as a percentage, between volumes (Stage I) or flow rates (Stage II) at specified intervals in the test procedure

3.2 stage I filterability

ratio, expressed as a percentage, between 240 ml and the volume of oil actually filtered in the time that 240 ml would have theoretically taken, assuming no plugging of the membrane

3.3 stage II filterability

ratio, expressed as a percentage, between the flow rate near the start of the filtration, and the flow rate between 200 ml and 300 ml of filtered volume

4 Principle

iTeh STANDARD PREVIEW
(standards.iteh.ai)

The test fluid is treated with water at an elevated temperature, filtered under specified conditions through a membrane of 0,8 µm mean pore diameter, and the times for the specified filtrate volumes are recorded. Filterabilities are calculated from ratios of the filtration rate near the start of filtration to the filtration rate at specified higher filtered volumes. The result of the test is the average of three determined values.

NOTE In the ideal situation, the filtration rate remains constant.

5 Reagents and materials

5.1 **Water**, conforming to grade 3 of ISO 3696.

5.2 **Propan-2-ol (isopropyl alcohol)**, filtered through a compatible 0,45 µm membrane filter.

NOTE A solvent-filtering dispenser, as shown in [Figure 1](#), is a means of dispensing this solvent, and the wash solvent ([5.3](#)).

5.3 **Wash solvent**, of light aliphatic hydrocarbon, filtered through a compatible 0,45 µm membrane filter (see NOTE under [5.2](#)). Heptane or 2,2,4-trimethylpentane is suitable.

5.4 **Compressed gas**, complete with regulator system capable of supplying gas at nominated pressures between 50 kPa and 200 kPa. The gas (air or nitrogen) shall be dry and filtered.

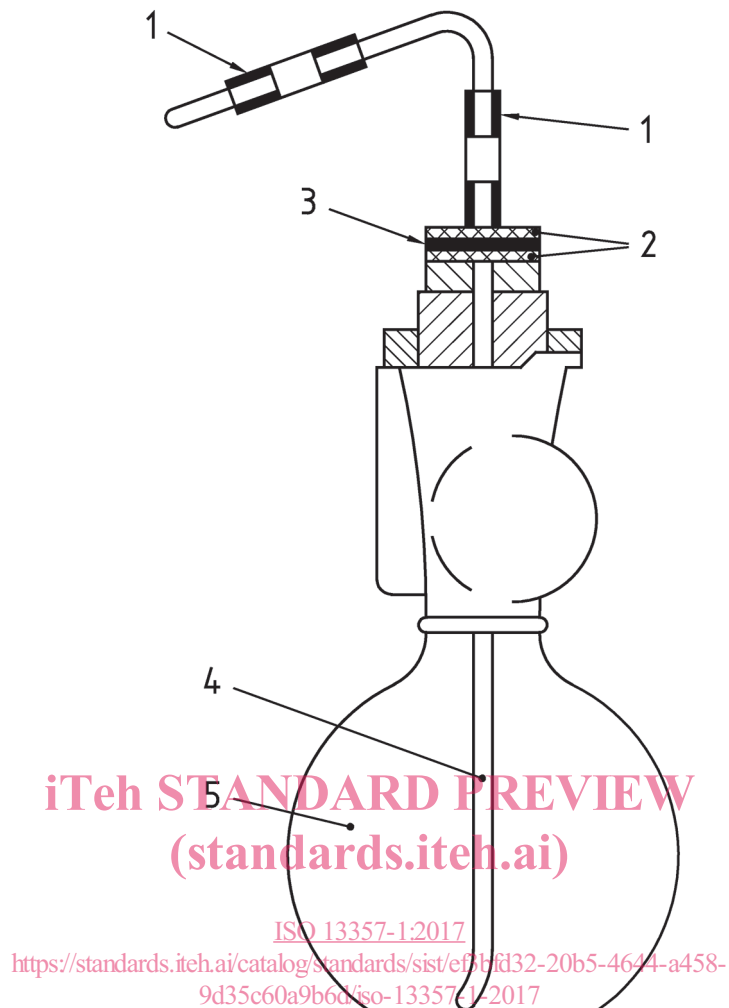

Key

- | | | | |
|---|-------------------------------------|---|----------------------------------|
| 1 | reagent-resistant plastic tubing | 4 | reagent-resistant plastic tubing |
| 2 | inert support screen | 5 | solvent-filtering dispenser |
| 3 | membrane filter, 0,45 μm | | |

Figure 1 — Solvent-filtering dispenser

6 Apparatus

6.1 Filtration apparatus, constructed of stainless steel, consisting of a lidded funnel of at least 350 ml capacity, and a funnel base with filter support, such that a membrane filter (6.2) can be clamped between the sealing surfaces of the funnel and the base by means of a metal clamp or other suitable gas-tight closure. The apparatus shall be grounded (earthed), and suitable electrical bonding of the parts shall be provided. The effective filtration area shall be $1\,130\text{ mm}^2 \pm 60\text{ mm}^2$. A schematic of the assembled apparatus, with the graphic symbols conforming to ISO 1219-1, is shown in [Figure 2](#).

6.2 Membrane filters, of mixed cellulose esters, diameter 47 mm and mean pore size of 0,8 μm .

NOTE Millipore membranes of an equivalent specification to their filter membranes, catalogue number AAWP04700¹⁾, have been found satisfactory.

All the membranes used for a single test (3 determinations) should be taken from a single box. If membranes are taken from more than one box, all boxes shall be from the same production batch.

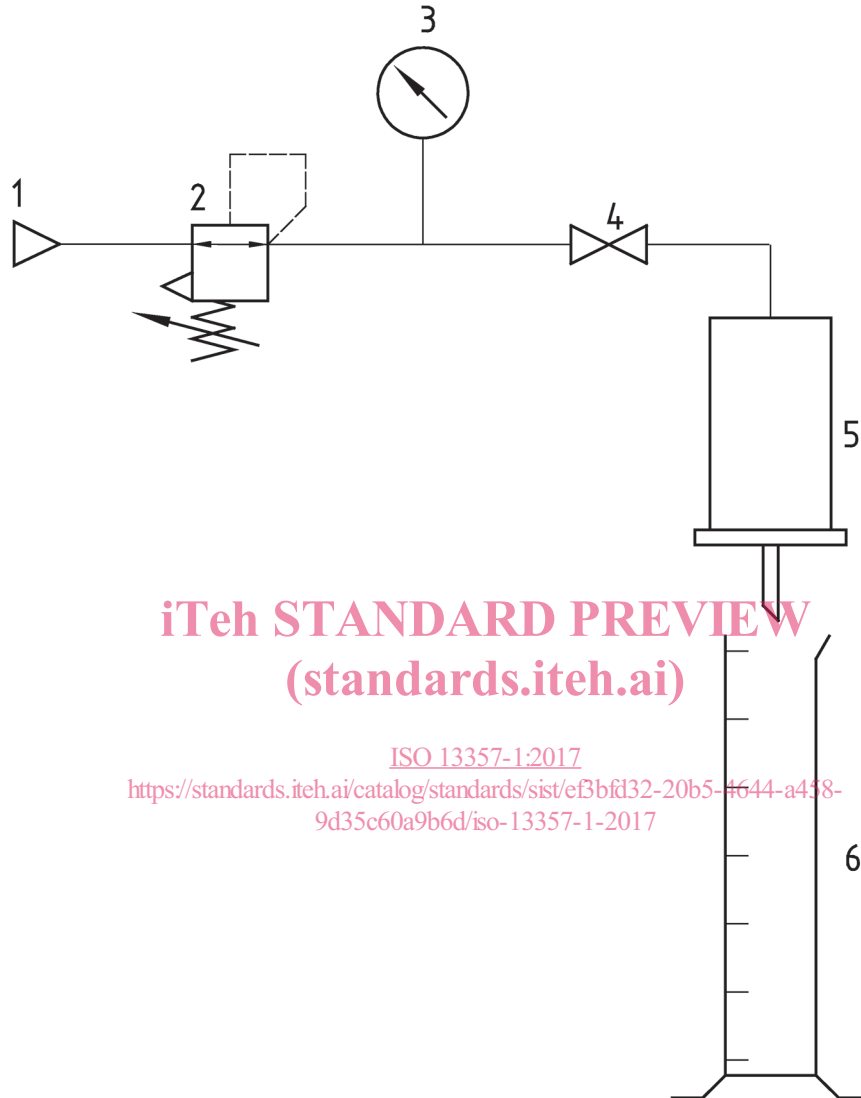

iTeh STANDARD PREVIEW
(standards.iteh.ai)

ISO 13357-1:2017

<https://standards.iteh.ai/catalog/standards/sist/ef3bfd32-20b5-4644-a438-9d35c60a9b6d/iso-13357-1-2017>

Key

- | | | | |
|---|--------------------------------------|---|---------------------------------------|
| 1 | source of compressed air or nitrogen | 4 | ball valve |
| 2 | pressure regulator | 5 | pressure vessel with membrane support |
| 3 | pressure gauge | 6 | measuring cylinder |

Figure 2 — Outline of assembled filtration apparatus

6.3 Measuring cylinders, one of borosilicate glass, of 250 ml capacity, conforming to the requirements of ISO 4788. This cylinder shall be permanently marked with further graduation marks at 10 ml and 300 ml. [Annex A](#) describes a procedure for adding these graduations. A second cylinder, capable of measuring 330 ml ± 5 ml, is also required for sample transfer.

1) Millipore membrane, catalogue number AAWP04700, is an example of a suitable product available commercially. This information is given for the convenience of users of this document and does not constitute an endorsement by ISO of this product.

NOTE 1 The 250 ml measuring cylinder has a total capacity in excess of 300 ml, allowing the extra graduations to be added. The use of a larger measuring cylinder for the filtration process would not give adequate precision for the test.

NOTE 2 It is advantageous, particularly with oils having very low electrical conductivity (e.g. ashless oils), to wrap the cylinder with a grounded (earthed) metal helix or mesh which does not obscure the graduations.

6.4 Pressure gauge, dial or digital type, capable of reading the required delivery pressures (see [9.12](#)) ± 5 kPa.

6.5 Forceps, spade-ended.

6.6 Timing device, electronic or mechanical, capable of reading to the nearest 0,2 s, and fitted with a dual-stop facility.

6.7 Oven, controlled at $70\text{ }^{\circ}\text{C} \pm 2\text{ }^{\circ}\text{C}$.

6.8 Petri dishes, loosely covered.

6.9 Bottles, of 500 ml laboratory type with screw caps. The exact shape of the bottle is unimportant, and 500 ml conical flasks can be used. However, the neck should be fairly narrow, but shall be wide enough to accept the stirrer ([6.10](#)). It is essential that the base of the bottle be fairly flat.

6.10 Motor and stirrer, conforming to the requirements of ISO 6614:1994, 6.3.

6.11 Pipettes.

6.11.1 Pasteur or dropping pipette.

ISO 13357-1:2017

<https://standards.iteh.ai/catalog/standards/sist/ef3bfd32-20b5-4644-a458-9d35c60a9b6d/iso-13357-1-2017>

6.11.2 1 ml graduated pipette.

7 Samples and sampling

7.1 Unless otherwise specified, samples shall be taken by the procedure specified in ISO 3170.

7.2 Shake the laboratory sample thoroughly by hand, and allow it to stand for 24 h at a temperature of $15\text{ }^{\circ}\text{C}$ to $25\text{ }^{\circ}\text{C}$. The laboratory temperature should not vary by more than $\pm 2\text{ }^{\circ}\text{C}$ for the duration of the test.

NOTE The optimum ambient laboratory temperature for precision is $22\text{ }^{\circ}\text{C}$.

8 Preparation of apparatus

8.1 Rinse the apparatus with wash solvent ([5.3](#)) to remove traces of oil from previous tests.

8.2 Soak in laboratory detergent solution overnight, or scrub thoroughly with hot laboratory detergent solution.

8.3 Rinse with hot tap water, followed by cold tap water.

8.4 Rinse with water ([5.1](#)).

8.5 Rinse with propan-2-ol ([5.2](#)).