



Designation: ~~E855–90(Reapproved 2000)~~ Designation: E 855 – 08

Standard Test Methods for Bend Testing of Metallic Flat Materials for Spring Applications Involving Static Loading¹

This standard is issued under the fixed designation E 855; the number immediately following the designation indicates the year of original adoption or, in the case of revision, the year of last revision. A number in parentheses indicates the year of last reapproval. A superscript epsilon (ϵ) indicates an editorial change since the last revision or reapproval.

1. Scope

1.1 This standard describes three test methods² for determining the modulus of elasticity in bending and the bending strength of metallic strips or sheets intended for the use in flat springs:

1.1.1 *Test Method A*—a cantilever beam,

1.1.2 *Test Method B*—a three-point loaded beam (that is, a beam resting on two supports and centrally loaded), and

1.1.3 *Test Method C*—a four-point loaded beam (that is, a beam resting on two supports and loaded at two points equally spaced from each support).

1.2 Values stated in inch-pound units are to be regarded as the standard. SI units are provided for information only.

1.2 The values stated in inch-pound units are to be regarded as standard. The values given in parentheses are mathematical conversions to SI units that are provided for information only and are not considered standard.

1.3 This standard does not purport to address all of the safety concerns, if any, associated with its use. It is the responsibility of the user of this standard to establish appropriate safety and health practices and determine the applicability of regulatory limitations prior to use.

2. Referenced Documents

2.1 The following documents of the issue in effect on date of use of these test methods form a part of these test methods to the extent referenced herein:

2.2 *ASTM Standards*:³

E 4 [Practices for Force Verification of Testing Machines](#)

E 6 [Terminology Relating to Methods of Mechanical Testing](#)

E 111 [Test Method for Young's Modulus, Tangent Modulus, and Chord Modulus](#)³—Test Method for Young's Modulus, Tangent Modulus, and Chord Modulus

E 177 [Practice for Use of the Terms Precision and Bias in ASTM Test Methods](#)

E 691 [Practice for Conducting an Interlaboratory Study to Determine the Precision of a Test Method](#) /astm-e855-08

3. Terminology

3.1 *Definitions of Terms Specific to This Standard*:

3.1.1 In addition to the terms in Terminology E 6, the following descriptions of terms apply in connection with these test methods for determining bend properties:

3.1.2 *bend properties*—those properties of a material that are associated with elastic and inelastic behavior when a bending force is applied, or that involve the relationship between bending stress and strain.

3.1.3 *bending stress at outer fiber* (FL^{-2})—the nominal stress in the outer fibers of a beam resulting from application of a bending load.

3.1.4 *elastic limit in bending* (FL^{-2})—the greatest bending stress that a material is capable of sustaining without permanent strain remaining after complete release of the bending moment.

3.1.5 *modulus of elasticity in bending* (FL^{-2})—the ratio of bending stress to corresponding strain below the elastic limit in bending.

¹ These test methods are under the jurisdiction of ASTM Committee E28 on Mechanical Testing and are the direct responsibility of Subcommittee E28.02 on Ductility and Flexure Testing-Formability.

Current edition approved March 30, 1990; Dec. 1, 2008. Published May 1990-January 2009. Originally published as E855–81; approved in 1981. Last previous edition E855–84; approved in 2005 as E 855 – 05.

² Method D, which appeared in the last previous edition, was dropped because of the unavailability of commercial testing equipment.

³ Annual Book of ASTM Standards, Vol 03.01.

³ For referenced ASTM standards, visit the ASTM website, www.astm.org, or contact ASTM Customer Service at service@astm.org. For *Annual Book of ASTM Standards* volume information, refer to the standard's Document Summary page on the ASTM website.

3.1.6 *span length (L)*—the distance between supports.

3.1.7 *uniform bending moment (FL)*—a bending moment that produces a uniform strain at the outer fibers throughout the gage length of the specimen.

3.1.8 *bending proof strength (FL^{-2})*—the nominal stress in the outer fibers of a beam that results in a specific permanent strain in the outer fibers upon unloading.

3.1.9 *cyclic bending yield strength (FL^{-2})*—the maximum nominal stress in uniform cyclic bending resulting from a given plastic deformation in the outer fibers of a beam.

3.1.10 *offset yield strength in bending (FL^{-2})*—the nominal stress in the outer fibers of a beam in bending at which a specified limiting deviation from proportionality of bending stress to bending strain is exhibited. The deviation is expressed in terms of strain.

4. Significance and Use

4.1 Measurements of bending strength and modulus of elasticity in bending should be made for materials whose principal stressing mode is bending. For many materials, the tensile and compressive moduli are somewhat different. Since the bending modulus is a combination of the tensile and compressive moduli, it is often different from each of them.

4.2 Precise measurements of the modulus of elasticity in bending and bending strength require due regard for numerous variables that may affect their determination. These include (1) characteristics such as specimen orientation with respect to the rolling direction, grain size, residual stresses, previous strain history, dimensions and specimen preparation, orientation of deformed grains relative to the direction of the normal stress; and (2) test conditions, such as temperature, temperature variations, condition of the test equipment and adherence to the recommended test procedure.

5. Fundamental Assumptions

5.1 The test section of the specimen is subjected to uniform bending moment (applies to Test Method C only).

5.2 The neutral axis is located at the centerline of the thickness of the test specimen.

5.3 Transverse cross sections of the beam remain plane and normal to the longitudinal fibers of the beam during bending.

5.4 The effect of shear stresses is negligible.

TEST METHOD A—CANTILEVER BEAM TEST

6. Scope

6.1 This test method covers the determination of the modulus of elasticity in bending and the offset yield strength in bending of flat metallic strips or sheets for spring applications. The test procedure involves measurements of the applied moment and the corresponding angle of deflection of a cantilever beam. The thickness range covered is 0.015 to 0.130 in. (0.38 to 3.30 mm). This test method is not applicable for nonlinear elastic materials.

7. Summary of Test Method

7.1 The test specimen is loaded as a simple cantilever beam, and the bending moment is measured at predetermined increments of angular deflection. When the maximum desired deflection is reached, the bending moment is removed and the permanent set angle resulting from the bend is recorded. All testing is performed under conditions of plane strain (that is, ratio of specimen width/thickness >10). The bending moment and deflection data obtained are normalized with regard to specimen geometry. These normalized terms are then plotted to produce a stress-strain curve for cantilever bending that is similar to a stress-strain curve for tension or compression. The modulus of elasticity in bending and the offset yield strength in bending are determined from the bending stress-strain curve using a procedure similar to that used for tensile stress-strain curves.

8. Significance and Use

8.1 This test method may be used for obtaining values of offset yield strength in bending and modulus of elasticity in bending. These values are useful to spring designers to determine spring constants and permissible maximum deflection of flat springs. It should be recognized that the offset yield strength in bending as determined by this test method is not necessarily equal to either the yield strength in tension, the cyclic yield strength in bending, or to bending proof strengths determined by other methods.

8.2 The test method can also serve the following purposes:

8.2.1 For research and development to study the effects of metallurgical variables, such as composition, heat treatment, fabrication operations and alloy development.

8.2.2 For information or specification purposes, to provide a manufacturing quality control where suitable correlations have been established with service behavior.

8.3 Due to necessary approximations in this test method regarding the specimen's deflection, D , and span, L , it is recommended that a deflection angle of 30° not be exceeded. These approximations are explained in Appendix X1.

8.4 Rate of loading is controlled only to the extent that the rate of angular change of the rotating jaw is fixed at 58 to $66^\circ/\text{min}$. Actual rate of stressing will depend on the specimen width and thickness and the weight of the pendulum.

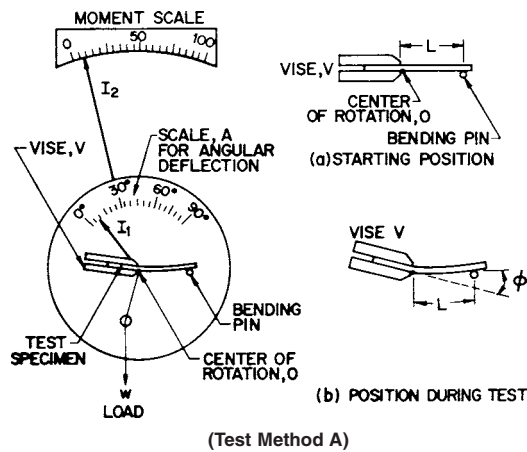

FIG. 1 Cantilever Bend Test Apparatus

9. Apparatus

9.1 The cantilever bend test apparatus⁴ shown in Fig. 1 consists of the following components:

9.1.1 *Specimen Holder*, A vise, V, to which an angular deflection indicator, I₁, is attached. The specimen holder is rotated about point O.

9.1.2 *Pendulum Weighing System*, composed of a set of detachable weights, an angular deflection scale with a moment pointer, I₂, a loading pin that transmits the bending force of the pendulum system to the free end of the cantilever specimen, and a weight to counter-balance the loading pin. The pendulum weighing system pivots about point O. For a pendulum system (Fig. 2) having no internal moments, the total bending moment, M, is:

$$M = w d \sin\theta \tag{1}$$

where:

M = bending moment at angle θ, lbf-in (N·m),

w = total load applied by pendulum system, lbf (N),

d = length of the pendulum arm, in (m), and

θ = angle through which the pendulum system rotates, rad.

9.1.3 *Angular Deflection Scale, A*, is graduated in degrees of arc and indicates the angle through which the rotating vise has been turned relative to the pendulum system. This is the difference between the angle through which the vise has been turned and the angle through which the load pendulum has been deflected, and is designated as angle φ. The loading pin has a diameter of 0.25 in. (6.35 mm), and the distance between the clamping point (that is, center of rotation of the pendulum system) and the center of the loading pin is 2.0 in. (50.8 mm). The reason for specifying the pin diameter and pin location is explained in Appendix X1.

9.1.4 *Moment Scale*— This stationary scale measures the applied moment as a function of the pendulum’s rotation θ. A full scale reading of 100 corresponds to the pendulum’s maximum bending moment, M_m. This system shall be calibrated such that the moment scale reading, f, is:

$$f = 100 w d \sin\theta / M_m \tag{2}$$

10. Test Specimens

10.1 Rectangular test specimens shall be used. Specimen orientation relative to the rolling direction must be identified. Specimen curvature due to coil set is permitted if the ratio of the radius of curvature to thickness exceeds 500. However, the specimen cannot be twisted or wavy. No attempt shall be made to flatten or straighten specimens prior to testing. Care shall be exercised not to alter the microstructure during specimen preparation. All burrs shall be removed before testing. Testing machine capacity will determine the maximum allowable specimen size.

10.2 The recommended minimum specimen thickness is 0.015 in. (0.38 mm). The thickness shall be measured at the four corners and the center of the specimen. Specimens having thickness variations in excess of 2 % of the average (of these five measured thicknesses) shall not be tested. The instrument used to measure the thickness shall have a precision within 2 % of the average thickness.

10.3 In Eq 3 in 11.1 it is shown that the value of the modulus of elasticity in bending varies as the third power of thickness. Hence, thickness is by far the most critical measurement in the determination of the modulus.

⁴ The Olsen Stiffness Tester meets the requirements of this test method.

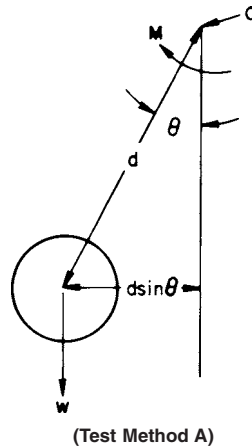

FIG. 2 Schematic of Pendulum System

NOTE 1—For example, an error in the thickness measurement of ± 0.0001 in. (0.0025 mm) for a specimen having the minimum recommended thickness of 0.015 in. (0.28 mm), the measurement is reproducible to within 0.67 % and the error in modulus attributable to the reproducibility of the thickness measurement is 2 %. Further, if the thickness actually varies by 2 % over the gage section or by 0.0003 in. (0.0075 mm), the error in modulus attributable to actual thickness variation is 6 %, and the total error attributable to both measurement and actual variation is 8 %. Additional sources of uncertainty are the precisions of determining the span length, the specimen width, and the beam deflection.

10.4 The ratio of the specimen span to thickness shall be greater than 15; consequently, since the span is 2.0 in. (50.8 mm), the specimen thickness cannot exceed 0.13 in. (3.30 mm).

10.5 The width to thickness ratio shall be greater than 10. The width shall be measured at both ends and the center of the specimen. Specimens having width variations greater than 0.5 % of the average width are not acceptable. The minimum specimen width shall be 0.5 in. (12.7 mm). The specimen width shall not extend beyond the vise or the loading pin.

11. Procedure

11.1 Place the machine on a level surface. Set the bending span to 2.0 in. (50.8 mm) and adjust the moment indicator to zero. For the best precision the maximum bending moment, M_m , should be chosen so that the moment scale reading is between 5 and 10 for an angular deflection of 3° . If this value is not known, it can be estimated as follows:

$$M_m = 25 E_b b h^3 \phi / f L \quad (3)$$

where:

M_m = pendulum's maximum bending moment, in-lbf (N·m),

E_b = modulus of elasticity in bending (can be approximated by Young's modulus) lbf/in.² (Pa),

b = specimen width, in. (m),

h = specimen thickness, in. (m),

ϕ = angular deflection, rad (0.052 rad (3°) specified here),

f = moment scale reading (select 7.5 in this case), and

L = span, 2 in. (50.8 mm).

11.2 Clamp the specimen firmly in the vise with its long edges approximately parallel to the face of the dial plate.

11.3 Manually rotate the vise to bring the specimen against the loading pin. When contact is made, the angular deflection indicator shall be set to indicate zero angle.

11.4 Hold down the motor engaging lever and record the moment scale readings at increments of 2° angular deflection (ϕ) until the desired deflection, not exceeding 30° , is reached. The specimen then shall be unloaded. The permanent set angle resulting from the bend shall be read on the angular deflection scale with the specimen contacting the loading pin at zero load.

11.5 A minimum of six specimens shall be tested from each sample. For specimens having an initial residual curvature, half of the specimens shall be tested with the concave surface facing upwards and half with the convex surface facing upwards. All specimens shall be deflected to the same maximum angle. The allowable maximum deflection angle is 30° .

11.6 Replication required for evaluating material variability within either the same sample or among several suppliers shall be covered in product specifications or upon agreement between supplier and user.

12. Calculation

12.1 The bending moment-deflection data are normalized with regard to specimen geometry and plotted on coordinate paper with the bending stress having ($3M_m f / 50 b h^2$) as the ordinate and the bending strain [$(3/2) (\phi h / L)$] as the abscissa (see Appendix X1). These symbols are defined in 11.1. The resulting bending curve is similar to a tension or compression stress-strain curve.

12.2 The value of the modulus of elasticity in bending, E_b , shall be determined by the slope of a straight line extending from the maximum deflection datum point (max) to the permanent set point (p.s.), that is:

$$E_b = [(M_m / f / 25bh^2) / ((\phi h / L)_{\max} - (\phi h / L)_{p.s.})] \quad (4)$$

$$E_b = (M_m / f / 25bh^2) / [(\phi h / L)_{\max} - (\phi h / L)_{p.s.}] \quad (4)$$

12.3 The first step in constructing the bending stress-strain curve is to draw a straight line having slope E_b such that it passes through the origin. The actual data points for elastic loading may be slightly displaced from this line. The non-linear portion of the bending stress-strain curve is constructed by drawing a curve through the remaining data points and connecting it with the modulus of elasticity line.

12.4 Offset yield strengths in bending can be obtained from the bending stress-strain curve using a procedure analogous to that used for tensile or compressive stress-strain curves. The offset yield strengths in bending for strains of 0.01, 0.05, and 0.10 % should be determined, provided this does not require that the maximum allowable deflection angle of 30° be exceeded.

NOTE 2—These values of offset yield strengths in bending are not necessarily equal to either the yield strengths in tension, the cyclic bending yield strength, or to bending proof strengths determined by other methods.

13. Report

13.1 The following shall be included in the report.

13.1.1 Complete description of the material tested, including alloy, temper, and manufacturer's identification number,

13.1.2 Specimen dimensions and orientation relative to the rolling direction,

13.1.3 Test temperature, and

13.1.4 The modulus of elasticity in bending and an estimate of the precision of the value reported.

13.1.5 Offset yield strengths in bending, for strains of 0.01, 0.05, and 0.10 % within the limitation of a maximum deflection angle of 30°, plus an estimate of the precision of the values reported.

13.1.6 Estimate of the precision of the values reported.

14. Precision and Bias

14.1 *Precision:*

14.1.1 The precision of the values of the modulus of elasticity in bending and the offset yield strength in bending will depend on the precision of each of the values used in the calculations, as well as the mean and standard deviation of the values determined for each of the replicate tests. It is suggested that the report include an estimate of the precision of the values reported.

14.1.2 The following parameters will affect the results and can be quantified as precision of the applied weights, precision of the span length measurement, deviation of width measurements from the average value, deviation of thickness measurements from the average value, and precision of the deflection measurements.

14.2 *Bias*—A statement of bias requires a reference standard or a true property value based on many measurements of the property of the same material. Such standards or true values are presently not available for bending properties of metallic flat spring materials. Therefore, the bias of the test method is unknown.

<https://standards.iteh.ai/catalog/standards/sist/7b8888f5-e984-4059-a567-6d092dd78a0b/astm-e855-08>

TEST METHOD B: THREE-POINT BEAM TEST TEST METHOD C: FOUR-POINT BEAM TEST

15. Scope

15.1 These test methods cover the determination of the modulus of elasticity in bending and the bending proof strength of flat metallic strips or sheets for spring applications. The test methods consist of deflection tests of a simple beam configuration subjected to either three- or four-point symmetrical loading. The thickness range covered is 0.010 to 0.050 in. (0.25 to 1.3 mm).

NOTE 3—Thickness ranges outside of those specified may be agreed upon between suppliers and users.

16. Summary of Test Methods

16.1 The test specimen is loaded as a simple beam in either three- or four-point symmetrical loading. The modulus of elasticity in bending is obtained by load-deflection measurements at stresses below the elastic limit. The bending proof strength is obtained by a stepwise increasing loading-unloading sequence carried out until a specified permanent set is measured on unloading.

NOTE 4—In these test methods the specified permanent set corresponds to a maximum outer fiber strain after springback of 0.0001 in./in. (mm/mm).

17. Significance and Use

17.1 These test methods are useful for obtaining values of proof strength in bending and modulus of elasticity in bending. These values are useful to spring designers to determine spring constants and maximum permissible deflection of flat springs. It should be recognized, however, that the proof strength in bending determined by these test methods is not necessarily equal to either the yield strength in tension or to the cyclic bending yield strength.

17.2 These tests can also serve the following purposes:

17.2.1 For research and development to study the effects of metallurgical variables such as composition, heat treatment, fabrication operations and alloy development.

17.2.2 For information or specification purposes, to provide a manufacturing quality control where suitable correlations have been established with service behavior.

17.3 For most loading systems and test specimens, effects of backlash, initial specimen curvature, and grip backlash introduce significant errors in the deflection or curvature measurement when applying a small load to the test specimen. Therefore, bending modulus measurements should be made between a preload high enough to minimize these effects, and a higher load known to be below the proportional or elastic limit. For linear elastic materials, the slope of the straight line portion of the bending–stress versus bending–strain curve should be established. For non-linear elastic materials the chord or tangent modulus may be established for stress values ranging from the appropriate preload to the elastic limit.

17.4 Because of difficulties associated with accurately establishing the origin of the stress-strain curve, due to the problems mentioned in 17.3, the use of secant modulus or initial tangent modulus is not recommended.

18. Apparatus

18.1 The apparatus consists of two adjustable supports and a means for measuring deflection or curvature and for applying load.

18.1.1 *Supports*—The supports should have a 60° angle with a radius of 0.005 in. (0.13 mm) at the supporting edge. One knife edge should be straight and the other convex (0.50 in. (13 mm radius of curvature)). Their mutual separation should be adjustable along the specimen longitudinal axis (Fig. 3).

18.1.2 *Load Application:*

18.1.2.1 *Applicator Geometry*—The load applicator shall have a 60° angle with a radius of 0.005 in. (0.13 mm). In the case of three-point loading the load is applied at midspan, using one such applicator as shown in Fig. 3. In the case of four-point loading, two load applicators are used, symmetrically spaced from the supports as shown in Fig. 4 and the distance between the load applicators shall equal 2/3 of the span length. One of the load applicators shall have a convex (0.50 in. (13 mm)) radius of curvature.

18.1.2.2 *Dead Weights*—Calibrated dead weights may be used with the load applicator. Any cumulative error in the dead weights or the dead weight loading system shall not exceed 1.0 %.

18.1.2.3 *Testing Machines*—In determining the suitability of a testing machine, it is advisable to calibrate the machine under conditions approximating those under which the tests will be made, together with the load applicators, in accordance with Practices E 4. Corrections may be applied for systematic errors in load. Any cumulative error in the machine loading system shall not exceed 1.0 %.

18.1.3 *Deflection Measurement Devices*— It is recommended that a deflectometer, or a cathetometer be used to determine the specimen deflection, δ , at midspan as shown in Fig. 3 and Fig. 4.

NOTE 5—If, in the case of universal testing machines the relative crosshead displacement is used as a measure of specimen deflection, proper correction must be made for machine and load cell stiffness.

18.1.3.1 The elastic deflection used in determining the modulus of elasticity in bending, and the permanent set used in determining the bending proof strength, shall be measured between outer supports to midspan. Interference forces from the measuring device must not exceed 0.05 % of the applied force during the test. Deflection shall be measured to an accuracy of ± 0.002 in. (0.05 mm).

19. Test Specimens

19.1 Rectangular test specimens shall be used. Specimen orientation relative to the rolling direction must be identified. Specimen curvature due to coil set shall be permitted if the ratio of the radius of curvature to thickness exceeds 500. The specimen shall not be twisted or wavy. No attempt shall be made to flatten or straighten specimens prior to testing. Care shall be exercised not to alter the microstructure during specimen preparation. All burrs shall be removed before testing.

19.2 The recommended minimum specimen thickness shall be 0.010 in. (0.25 mm). The thickness shall be measured at the four corners and at the center of the specimen’s gage section. Specimens having measured thickness variations in excess of 2 % of the

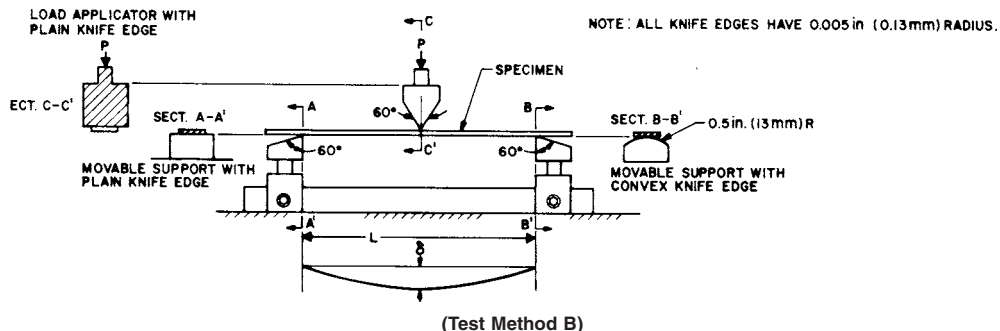

FIG. 3 Three-Point Bend Test