



Standard Test Method for Vapor-Phase Rust-Preventing Characteristics of Hydraulic Fluids¹

This standard is issued under the fixed designation D 5534; the number immediately following the designation indicates the year of original adoption or, in the case of revision, the year of last revision. A number in parentheses indicates the year of last reapproval. A superscript epsilon (ϵ) indicates an editorial change since the last revision or reapproval.

1. Scope

1.1 This test method covers the ability of hydraulic fluids to prevent the rusting of steel in the vapor phase over the hydraulic fluid and water.

1.2 The values stated in SI units are to be regarded as the standard. The values given in parentheses are for information only.

1.3 *This standard does not purport to address all of the safety concerns, if any, associated with its use. It is the responsibility of the user of this standard to establish appropriate safety and health practices and determine the applicability of regulatory limitations prior to use.*

2. Referenced Documents

2.1 ASTM Standards:

A 108 Specification for Steel Bars, Carbon, Cold Finished, Standard Quality²

A 240 Specification for Heat-Resisting Chromium and Chromium-Nickel Stainless Steel Plate, Sheet, and Strip for Pressure Vessels³

D 91 Test Method for Precipitation Number of Lubricating Oils⁴

D 665 Test Method for Rust-Preventing Characteristics of Inhibited Mineral Oil in the Presence of Water⁴

D 1193 Specification for Reagent Water⁵

D 3603 Test Method for Rust-Preventing Characteristics of Steam Turbine Oil in the Presence of Water (Horizontal Disk Method)⁶

E 1 Specification for ASTM Thermometers⁷

2.2 Other Standards:

IP 60/80 Specification for Petroleum Spirit⁸

3. Summary of Test Method

3.1 This test method is divided into two parts:

3.1.1 Part A is used only for fluids where water is the continuous phase. Examples of such fluids include water-glycol hydraulic fluids and high-water-content hydraulic fluids. Do not use Part A to evaluate invert emulsion hydraulic fluids.

3.1.2 Part B can be used for both water-containing fluids and completely water-free fluids such as petroleum based hydraulic fluids, except phosphate esters. In Part B a small beaker of water is present to provide water vapor to cause corrosion in the absence of a vapor-phase inhibitor in the fluid. Part B is the appropriate procedure for evaluating invert emulsion hydraulic fluids.

3.2 In both Part A and Part B, a steel specimen is attached to the underside of the cover of a beaker containing the fluid under test. The apparatus and specimen are identical to those of Test Method D 3603. The fluid is brought to a test temperature of 60°C (140°F).

3.3 In Part B, the test specimen is exposed to the vapor from the fluid for 30 min prior to the introduction of water. A beaker of water is then placed in the undercarriage of the cover.

3.4 After 6 h, the apparatus is disassembled and the specimen is rated visually for the presence of rust.

3.5 Since the apparatus and test conditions are identical, Part A can be completed simultaneously with Test Method D 3603 by adding the vapor-phase specimen to that procedure.

4. Significance and Use

4.1 Procedures such as Test Methods D 665 and D 3603 assess the ability of new or unused hydraulic fluid to prevent rusting on wetted steel surfaces but do not address the prevention of rusting in the vapor space above the fluid. This procedure addresses the latter question under one set of test conditions and need not be applicable to some service conditions. Since used fluids have not been cooperatively tested in this procedure, its utility for in-service monitoring has not been established.

¹ This test method is under the jurisdiction of ASTM Committee D-2 on Petroleum Products and Lubricants and is the direct responsibility of Subcommittee D02.N on Hydraulic Fluids.

Current edition approved Apr. 15, 1994. Published June 1994.

² Annual Book of ASTM Standards, Vol 01.05.

³ Annual Book of ASTM Standards, Vol 01.03.

⁴ Annual Book of ASTM Standards, Vol 05.01.

⁵ Annual Book of ASTM Standards, Vol 11.01.

⁶ Annual Book of ASTM Standards, Vol 05.02.

⁷ Annual Book of ASTM Standards, Vol 14.03.

⁸ Available from Applied Science Publishers, Ltd., Ripple Road, Barking, Essex, England.

5. Apparatus

5.1 *Oil Bath*, a thermostatically controlled liquid bath capable of maintaining a temperature in the oil sample of $60 \pm 1^\circ\text{C}$ ($140 \pm 2^\circ\text{F}$). The bath shall have holes to accommodate the test beakers.

NOTE 1—The bath used for Test Method D 665 can be used with a slight modification, that is, the centers of the beaker holes are moved from 6.4 mm to 18.3 mm ($\frac{1}{4}$ to $\frac{23}{32}$ in.) from the axis of the stirrers.

NOTE 2—To indicate the temperature, a thermometer conforming to the requirements of ASTM Thermometer 9C or 9F, or IP Thermometer 21C, as prescribed in Specification E 1 should be used.

5.2 *Beaker*, a 400-mL, Berzelius-type, tall-form heat resistant glass beaker,⁹ approximately 127 mm (5 in.) in height measured from the inside bottom center and approximately 70 mm ($2\frac{3}{4}$ in.) in inside diameter measured at the middle, and without pourout (see Fig. 1).

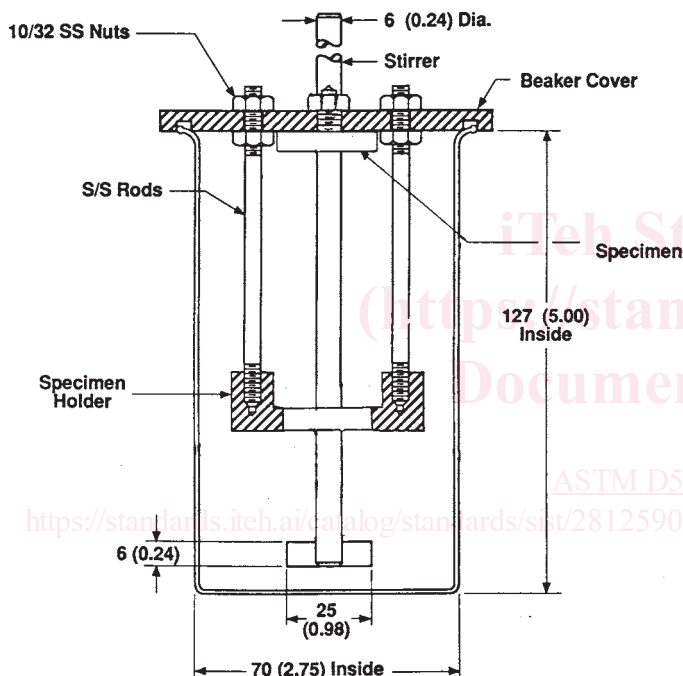

NOTE 1—All dimensions are in millimetres (inches).
FIG. 1 Rusting Test Apparatus

5.3 *Beaker Cover* (Fig. 2) and *Specimen Holder* (Fig. 3)—a flat beaker cover of 4.8 mm ($\frac{3}{16}$ in.) methyl methacrylate resin or other fluid-resistant material, kept in position by a suitable groove. Three holes, 7.9 mm ($\frac{5}{16}$ in.) in diameter, shall be provided. Two are located on any diameter of the cover, one for a stirrer 18.3 mm ($\frac{23}{32}$ in.) from the cover's center, and the other for the vapor-phase test specimen 7.9 mm ($\frac{5}{16}$ in.) from the center on the opposite side. The third hole, for a thermometer, is located 27 mm ($1\frac{1}{16}$ in.) from the center on a diameter perpendicular to that of the other two holes. The undercarriage is a Test Method D 3603 specimen holder suitably attached to the beaker cover, used here to support the water beaker (see

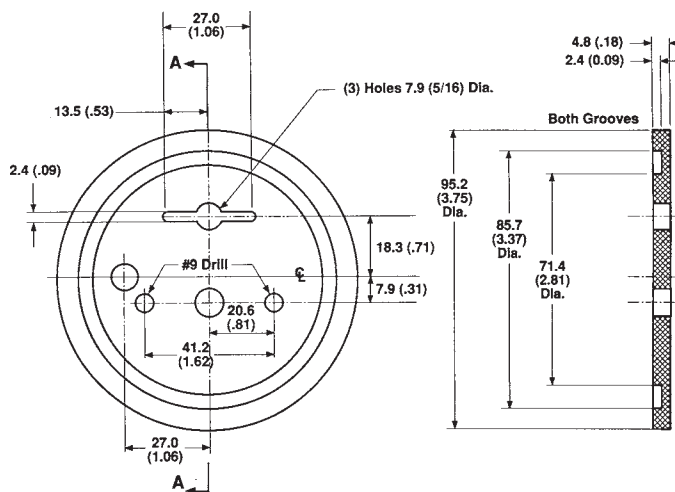

NOTE 1—All dimensions are in millimetres (inches).
FIG. 2 Beaker Cover

5.7) used in Part B. One suitable undercarriage (the one used in the round-robin) is shown in Fig. 1. An undercarriage must be present even for Part A, to prevent vortexing. The holding rod, appropriate for this apparatus, is depicted in Fig. 4.

NOTE 3—Other holders suitable for supporting the specimen in Test Method D 3603 are also suitable for supporting the water beaker in this test method. The undercarriage design is not considered to be critical.

5.4 *Stirrer*, a stirrer constructed entirely from stainless steel in the form of an inverted T (Fig. 5). A flat blade 25.4 by 6.1 by 0.6 mm (1 by 0.24 by 0.024 in.) shall be attached to a 6.1 mm (0.24 in.) rod in such a way that the blade is symmetrical with the rod and has its flat surface in the vertical plane.

NOTE 4—A suitable material is an 18 % chromium, 8 % nickel alloy steel conforming to Type 304 of Specification A 240, or SAE No. 30304, or BS 970: Part 1: 1983: 302531.

NOTE 5—If stainless steel is not available, stirrers made of heat resistant glass and having approximately the same dimensions as the stainless steel stirrers can be used.¹⁰

5.5 *Stirring Apparatus*—any convenient form of stirring apparatus capable of maintaining a speed of 1000 ± 50 rpm.

5.6 *Grinding and Polishing Equipment*—a 150- and 240-grit metalworking aluminum oxide abrasive cloth,¹¹ closed coat on a jeans backing, a suitable chuck (Fig. 6) for holding the specimen, and a means of rotating the specimen at a speed of 1700 to 1800 rpm.

5.7 *Water Beaker for Part B*—a flat-bottomed beaker made from 30 mm (1.2 in.) outside diameter standard wall glass tubing, 50 mm (2.0 in.) high. It should fit snugly in the undercarriage of the specimen holder.

6. Reagents and Materials

6.1 *Cleaning Agents*—One of the following shall be used.

6.1.1 *ASTM Precipitation Naphtha*, conforming to Test Method D 91.

¹⁰ Borosilicate glass is satisfactory for this purpose.

¹¹ Annual Book of ASTM Standards, Vol 05.04 (gray pages).

⁹ British Standard 2, 1965 Section 5, or equivalent, may be used.