**Tissue paper and tissue products —
Part 5:
Determination of wet tensile strength**

Papier tissue et produits tissue —

Partie 5: Détermination de la résistance à la rupture par traction à l'état humide

iTeh STANDARD PREVIEW
(standards.iteh.ai)

[ISO 12625-5:2016](https://standards.iteh.ai/catalog/standards/sist/3f4a7018-ca1d-404f-8365-c5765583ef40/iso-12625-5-2016)

<https://standards.iteh.ai/catalog/standards/sist/3f4a7018-ca1d-404f-8365-c5765583ef40/iso-12625-5-2016>



iTeh STANDARD PREVIEW
(standards.iteh.ai)

ISO 12625-5:2016

<https://standards.iteh.ai/catalog/standards/sist/3f4a7018-ca1d-404f-8365-c5765583ef40/iso-12625-5-2016>



COPYRIGHT PROTECTED DOCUMENT

© ISO 2016, Published in Switzerland

All rights reserved. Unless otherwise specified, no part of this publication may be reproduced or utilized otherwise in any form or by any means, electronic or mechanical, including photocopying, or posting on the internet or an intranet, without prior written permission. Permission can be requested from either ISO at the address below or ISO's member body in the country of the requester.

ISO copyright office
Ch. de Blandonnet 8 • CP 401
CH-1214 Vernier, Geneva, Switzerland
Tel. +41 22 749 01 11
Fax +41 22 749 09 47
copyright@iso.org
www.iso.org

Contents

	Page
Foreword	iv
1 Scope	1
2 Normative references	1
3 Terms and definitions	1
4 Principle	2
5 Apparatus	2
6 Conditioning	5
7 Preparation	5
7.1 General	5
7.2 Accelerated ageing (curing)	5
7.3 Dimensions	6
7.3.1 Vertical testing apparatus	6
7.3.2 Horizontal testing apparatus	6
7.4 Number of test pieces	6
8 Procedure	6
8.1 Calibration and adjustment of the testing apparatus	6
8.2 Vertical test method	7
8.2.1 Mounting the Finch Cup soaking device	7
8.2.2 Measurement	7
8.3 Horizontal test method	8
8.3.1 Measurement	8
9 Calculation	9
9.1 General	9
9.2 Wet tensile strength	9
9.3 Wet tensile strength retention	10
10 Test report	10
Annex A (informative) Precision	11
Bibliography	15

Foreword

ISO (the International Organization for Standardization) is a worldwide federation of national standards bodies (ISO member bodies). The work of preparing International Standards is normally carried out through ISO technical committees. Each member body interested in a subject for which a technical committee has been established has the right to be represented on that committee. International organizations, governmental and non-governmental, in liaison with ISO, also take part in the work. ISO collaborates closely with the International Electrotechnical Commission (IEC) on all matters of electrotechnical standardization.

The procedures used to develop this document and those intended for its further maintenance are described in the ISO/IEC Directives, Part 1. In particular the different approval criteria needed for the different types of ISO documents should be noted. This document was drafted in accordance with the editorial rules of the ISO/IEC Directives, Part 2 (see www.iso.org/directives).

Attention is drawn to the possibility that some of the elements of this document may be the subject of patent rights. ISO shall not be held responsible for identifying any or all such patent rights. Details of any patent rights identified during the development of the document will be in the Introduction and/or on the ISO list of patent declarations received (see www.iso.org/patents).

Any trade name used in this document is information given for the convenience of users and does not constitute an endorsement.

For an explanation on the meaning of ISO specific terms and expressions related to conformity assessment, as well as information about ISO's adherence to the World Trade Organization (WTO) principles in the Technical Barriers to Trade (TBT) see the following URL: www.iso.org/iso/foreword.html.

This document was prepared by the European Committee for Standardization (CEN) Technical Committee CEN/TC 172, *Pulp, paper and board*, in collaboration with ISO Technical Committee TC 6, *Paper, board and pulps*, Subcommittee SC 2, *Test methods and quality specifications for paper and board*, in accordance with the Agreement on technical cooperation between ISO and CEN (Vienna Agreement).

This second edition cancels and replaces the first edition (ISO 12625-5:2005), which has been technically revised with the following changes:

- a) in [Clause 7](#), a more detailed description of the preparation of the test pieces was included;
- b) in [Clause 8](#), the procedure for measurement was clarified;
- c) in [Clause 10](#), additional information is to be included in the test report;
- d) more detailed precision data in [Annex A](#);
- e) this document has been editorially updated.

A list of all parts in the ISO 12625 series can be found on the ISO website.

Tissue paper and tissue products —

Part 5: Determination of wet tensile strength

1 Scope

This document specifies a test method for the determination of the wet tensile strength of tissue paper and tissue products after soaking with water, using a tensile-strength-testing apparatus operating with a constant rate of elongation.

Currently, two types of tensile-strength-testing apparatus are commercially available, one where the test piece is positioned vertically and, for the other, horizontally. This document applies for both. For vertical tensile-strength-testing apparatus, a device which is held in the lower grip of the tensile-strength-testing apparatus, called a Finch Cup, is used to achieve the wetting. For horizontal tensile-strength-testing apparatus, the soaking device is placed between the clamps.

In cases where impurities and contraries have to be determined, ISO 15755^[6] applies for these detections in tissue paper and tissue products.

iTeh STANDARD PREVIEW

2 Normative references (standards.iteh.ai)

The following documents are referred to in the text in such a way that some or all of their content constitutes requirements of this document. For dated references, only the edition cited applies. For undated references, the latest edition of the referenced document (including any amendments) applies.

ISO 186, *Paper and board — Sampling to determine average quality*

ISO 187, *Paper, board and pulps — Standard atmosphere for conditioning and testing and procedure for monitoring the atmosphere and conditioning of samples*

ISO 1924-2, *Paper and board — Determination of tensile properties — Part 2: Constant rate of elongation method (20 mm/min)*

ISO 7500-1, *Metallic materials — Calibration and verification of static uniaxial testing machines — Part 1: Tension/compression testing machines — Calibration and verification of the force-measuring system*

3 Terms and definitions

For the purposes of this document, the terms and definitions given in ISO 12625-1 and the following apply.

ISO and IEC maintain terminological databases for use in standardization at the following addresses:

- IEC Electropedia: available at <http://www.electropedia.org/>
- ISO Online browsing platform: available at <http://www.iso.org/obp>

3.1

wet tensile strength

maximum tensile force per unit width that a test piece soaked with water will withstand before breaking in a tensile test

Note 1 to entry: The wet tensile strength is expressed in newtons per metre (N/m).

3.2 wet-tensile-strength retention

ratio, expressed as a percentage, of the tensile strength of the wet test piece to the tensile strength of a different test piece from the same sample in the dry, conditioned state

Note 1 to entry: According to ISO 187.

4 Principle

A test piece of tissue paper or tissue product of given dimensions, soaked in water for a given period of time under specified conditions, is stretched (elongated) to break at a constant rate of elongation, using a tensile-strength-testing apparatus that measures and records the tensile force as a function of the elongation of the test piece.

The test can be carried out by a vertical or a horizontal tensile-strength-testing apparatus.

In order to wet the test pieces for a vertical tensile-strength-testing apparatus, a device called a Finch Cup, which is held to the lower clamp, is used. For a horizontal tensile-strength-testing apparatus, a soaking cup is inserted between the clamps.

From the wet tensile strength and the tensile strength of the same sample in the dry conditioned state, the wet-tensile-strength retention can be calculated.

Precision data are available in [Annex A](#).

iTeh STANDARD PREVIEW (standards.iteh.ai)

5 Apparatus

5.1 Vertical tensile-strength-testing apparatus

ISO 12625-5:2016

5.1.1 Tensile-strength-testing apparatus

<https://standards.iteh.ai/catalog/standards/sist/3f4a7018-ca1d-404f-8365-c5765583e40/iso-12625-5-2016>

The tensile-strength-testing apparatus shall be in accordance with ISO 1924-2. It is capable of stretching a test piece of tissue paper or tissue product of given dimensions at a constant rate of elongation of (50 ± 2) mm/min, and recording the tensile force as a function of elongation on a strip chart recorder or any equivalent device.

The force-measuring system shall measure loads with an accuracy of ± 1 % of the reading or $\pm 0,1$ N, whichever is greater, and shall be calibrated and verified according to the requirements of ISO 7500-1.

5.1.2 Tensile-testing apparatus clamps

The tensile-strength-testing apparatus (5.1.1) shall have an upper clamp with a minimum of 50 mm width, for holding both ends of the test piece firmly and without slippage. To avoid damaging the test pieces, the clamp surfaces that touch the pieces should be smooth and have rounded edges, i.e. free from burrs. The lower clamp shall be designed to grip the Finch Cup soaking device (5.1.3) firmly. The clamps shall have means for adjusting the clamping force.

During the test, the upper clamping line and the Finch Cup soaking device (5.1.3) rod shall be parallel to each other. They shall also be perpendicular to the direction of the applied tensile force and to the length axis of the test piece.

The distance between A and B is the total span length and shall be (100 ± 1) mm. The distance between A and B divided by two is the test span length and shall be (50 ± 1) mm.

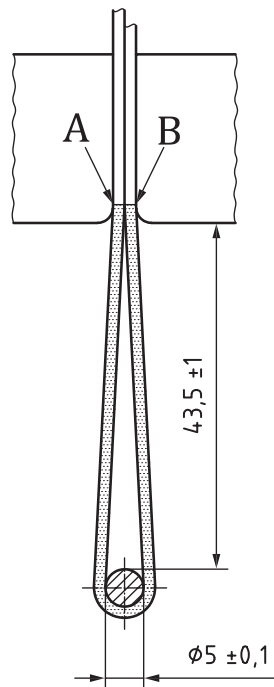
**Key**

- A clamping line on one end of the test piece
 B clamping line on the other end of the test piece

Figure 1 — Positioning of a test piece

ISO 12625-5:2016

<https://standards.iteh.ai/catalog/standards/sist/3f4a7018-ca1d-404f-8365-c5765583e40/iso-12625-5-2016>

5.1.3 Finch Cup soaking device

A Finch Cup soaking device (see [Figure 2](#)) consists of a support system that holds a horizontal cylindrical rod of $(5,0 \pm 0,1)$ mm diameter, and approximately 60 mm length, and a water container.

The water container shall be constructed such that it can be moved vertically and locked in a raised position. In the locked raised position, the water in the container shall completely surround the cylindrical rod which is thereby immersed in the liquid to a depth of (20 ± 1) mm, as indicated in [Figure 2](#).

Projecting downwards, from the bottom of the device, is a rigid metal tongue by means of which the device can be held in the lower clamp of the tensile-strength-testing apparatus.

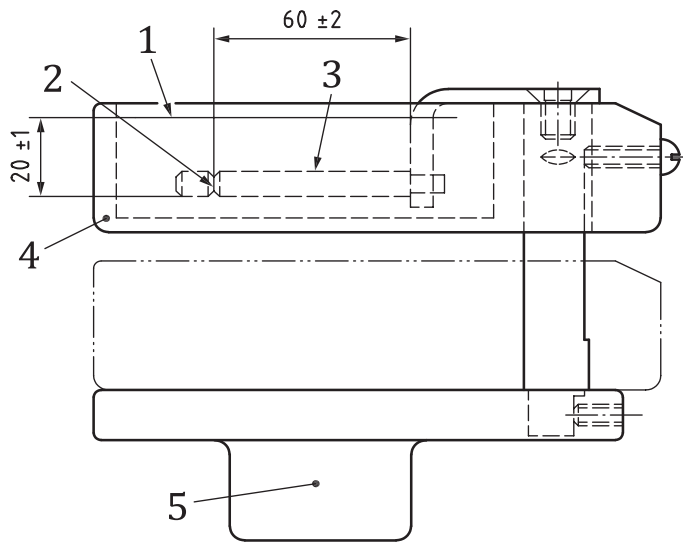

Key

- 1 liquid level mark
- 2 positioning groove
- 3 rod, $d (5,0 \pm 0,1)$ mm
- 4 water container (movable)
- 5 tongue

iTeh STANDARD PREVIEW
(standards.iteh.ai)

Figure 2 — Finch Cup soaking device (example)

ISO 12625-5:2016

5.2 Horizontal tensile-strength-testing apparatus

<https://standards.iteh.ai/catalog/standards/sist/3f4a7018-ca1d-404f-8365-c5765583e140/iso-12625-5-2016>

5.2.1 Tensile-strength-testing apparatus

The tensile-strength-testing apparatus shall be in accordance with ISO 1924-2. It is capable of stretching a test piece of tissue paper or tissue product of given dimensions at a constant rate of elongation of (50 ± 2) mm/min, and recording the tensile force as a function of elongation on a strip chart or any equivalent device.

The force-measuring system shall measure loads with an accuracy of $\pm 1\%$ of the reading or $\pm 0,1$ N, whichever is greater. It shall be calibrated and verified to confirm the requirements of ISO 7500-1.

5.2.2 Tensile-testing apparatus clamps

The tensile-strength-testing apparatus shall have two clamps for holding the test piece. Each clamp shall be designed to grip the test piece firmly along a straight line across the full width of the test piece, without causing any damage, and shall have means for adjusting the clamping force. The table between the clamps shall be removable.

During the test, the clamping lines shall be parallel to each other within an angle of 1° . The clamping lines shall be perpendicular to the direction of the applied tensile force and to the longest dimension of the test piece to the same level of accuracy.

The distance between the clamping lines (i.e. the test span length) shall be adjusted to (100 ± 1) mm, except that a test span length of (50 ± 1) mm shall be used for finished paper products of which one or both of the dimensions is insufficient to provide a test piece of the length required in 7.3.

5.2.3 Soaking device

A soaking device can be inserted between the clamps of the tensile-strength-testing apparatus (5.2.2), as shown in Figure 3.

The soaking device may be equipped with a device that, between the measurements, will adjust the water to a constant level.

5.3 Cutting device

The cutting device shall be capable of repeatedly cutting test pieces (50,0 ± 0,5) mm wide and at least 150 mm in length, with undamaged, straight, smooth and parallel edges.

6 Conditioning

Condition the samples according to ISO 187 and keep them in the standard atmosphere throughout the test.

Conditioning shall be done prior to the preparation of test pieces.

7 Preparation

7.1 General

7.1.1 If the tests are being made to evaluate a lot, the sample shall be selected in accordance with ISO 186.

If the tests are being made on another type of sample, make sure that the specimens taken are representative of the sample. Each test piece shall be free from perforations and faults not normally inherent to the tissue.

Handling of wet samples shall be avoided.

7.1.2 For converted tissue products, testing shall be done on the product as received, regardless of the number of plies which are supplied as a product unit. Generally, a single finished product sheet is suitable for use as a test piece.

7.1.3 Tissue that has not been converted into a finished product shall be tested as a single ply, unless otherwise agreed between the parties concerned.

7.2 Accelerated ageing (curing)

7.2.1 The wet strength of tissue paper is frequently enhanced by addition of a wet strength agent. An accelerated ageing with heat, also called curing, is frequently used to develop the maximum wet strength that a tissue paper or tissue product will achieve after a period of natural ageing at ambient conditions, which may vary from a few days to several weeks based on the wet strength agent used.

NOTE The decision of whether or not to use accelerated ageing will be determined by the user of this document, based upon the information about the tissue paper or tissue product sample being tested. Accelerated ageing is not a requirement of this document, but is an allowed option.

There is no rule for determining whether to rapid age or not, but the following principles are generally applied.

7.2.2 Production test pieces which have not left the manufacturing environment are generally rapid aged. To rapid age a tissue paper or tissue product, it is recommended to heat it in an oven at (80 ± 2) °C

for 30 min. After heating, condition the test piece in a standard atmosphere at $(23 \pm 1) ^\circ\text{C}$ and $(50 \pm 2) \%$ relative humidity for at least 1 h prior to testing.

For production inspections where data shall be available quickly, accelerated ageing conditions of $(105 \pm 2) ^\circ\text{C}$ for 15 min may be used.

7.2.3 Test pieces which have been delivered into the marketing chain, and especially those available for sale to the ultimate consumer, are generally not aged.

It shall be understood that the wet strength of test pieces after accelerated ageing may be different than that which will be experienced by the end user of the product.

The test report shall state whether the test piece is rapid aged or not and, if so, by what procedure.

7.3 Dimensions

7.3.1 Vertical testing apparatus

Each test piece shall be $(50,0 \pm 0,5)$ mm in width and at least 150 mm in length. For finished tissue product items of very short dimensions, cut the longest test piece possible and reduce the distance between the top edge of the rod of the Finch Cup soaking device and the bottom edge of the upper clamp of the tensile-strength-testing apparatus from $(43,5 \pm 1,0)$ mm to $(23,5 \pm 1,0)$ mm.

7.3.2 Horizontal testing apparatus

Cut test pieces of $(50,0 \pm 0,5)$ mm width and, preferably, approximately 150 mm length, avoiding perforations and faults.

If the specimens are so small that test pieces of 150 mm length cannot be obtained, cut test pieces as long as the specimens allow and, when testing these test pieces, use the maximum test span that can be used with secure clamping.

The test span shall be reported [see [Clause 10 e](#))].

7.4 Number of test pieces

Take at least 10 specimens from each sample of tissue product. From each specimen, cut one test piece in the machine direction and one test piece in the cross direction, making a total of at least 20 test pieces from each sample of tissue paper or tissue product.

8 Procedure

8.1 Calibration and adjustment of the testing apparatus

Ensure that the tensile-strength-testing apparatus is calibrated and verified in accordance with the requirements of ISO 7500-1.

Check that the clamps are aligned to meet the requirements in [5.2.2](#). Position the clamps such that the test span is (100 ± 1) mm. Adjust the rate of elongation (the rate of separation of the clamps) to (50 ± 2) mm/min or the adapted dimension, if required, as stated in [7.3.1](#) or in [7.3.2](#), respectively. Adjust the clamping force in such a way that the test piece does not slip or suffer damage during the test.

8.2 Vertical test method

8.2.1 Mounting the Finch Cup soaking device

With the rod of the Finch Cup soaking device in a horizontal position, clamp the Finch Cup soaking device with its rigid tongue projecting from the button of the device in the lower clamp of the tensile-strength-testing apparatus.

Pre-set the distance between the top edge of the rod of the Finch Cup soaking device and the bottom edge of the upper clamp of the tensile-strength-testing apparatus at $(43,5 \pm 1,0)$ mm. In this case, the total test span length of a dry test piece looped under the rod will be (100 ± 1) mm. Half this distance is regarded as the test span length. In the case of very short specimens, this distance may be reduced to $(23,5 \pm 1,0)$ mm (see 7.3.1).

8.2.2 Measurement

8.2.2.1 Wet tensile strength

Place the water container in its bottom position and fill it up to the mark with distilled or deionized water at (23 ± 1) °C. Dry finch rod thoroughly and any other part that may come into contact with the test pieces. Insert the dry test piece horizontally under the dry rod, bend it around the rod, creating a loop, and clamp the two ends of the test piece in the upper clamp of the tensile-strength-testing apparatus as shown in Figure 1. Ensure that both ends of the looped test piece are held by the clamp, tightened without causing damage, while avoiding slippage during the test. Align the test piece as parallel as possible to the pulling direction and initiate the test.

Raise the water container until it locks in its upper position, thereby immersing the looped end of the test piece to a depth of at least 20 mm below the initial water level.

Immediately start a stopwatch. <https://standards.iteh.ai/catalog/standards/sist/3f4a7018-ca1d-404f-8365-c5765583ef40/iso-12625-5-2016>

After soaking for 15 s, lower the water container to its lowest position. Then, immediately initiate the tensile test. Determine the wet tensile strength of the wet test piece at an elongation rate of (50 ± 2) mm/min.

Record all readings, except if the test piece breaks on the rod of the Finch Cup soaking device or within 2 mm of the clamping line of the upper clamp, until 10 valid results are available for each direction.

If more than 20 % of the test pieces cut from a particular specimen break with 2 mm from the clamping line or on the rod, reject all the readings obtained for that specimen. Inspect the apparatus for conformity with the specifications and take the appropriate remedial measures.

After each test, wipe dry the horizontal rod of the Finch Cup soaking device before attaching the next test piece. After each test, top up the water container with distilled or deionized water. After each set of samples, clean and refill the water container.

8.2.2.2 Wet-tensile-strength retention

If the wet-tensile-strength retention is to be determined, remove the water from the soaking cup. Dry the finch rod thoroughly and any other part that may come into contact with the test pieces. Measure the dry tensile strength of the conditioned test pieces as described in this document.