



## Standard Test Method for Life Performance of Automotive Wheel Bearing Grease<sup>1</sup>

This standard is issued under the fixed designation D 3527; the number immediately following the designation indicates the year of original adoption or, in the case of revision, the year of last revision. A number in parentheses indicates the year of last reapproval. A superscript epsilon ( $\epsilon$ ) indicates an editorial change since the last revision or reapproval.

---

---

<sup>ε1</sup> NOTE—Added Note 5 editorially in January 2009.

---

---

### 1. Scope

1.1 This test method covers a laboratory procedure for evaluating the high-temperature life performance of wheel bearing greases when tested under prescribed conditions.

NOTE 1—Changes to this test method in the 1985 revision increased test severity. Results will not be comparable with data from earlier procedures.

~~1.2 The values stated in SI units, except apparatus dimensions, are to be regarded as the standard. Apparatus dimensions in inches are to be regarded as the standard.~~

1.2 The values stated in SI units are to be regarded as standard. No other units of measurement are included in this standard.

1.2.1 *Exception*—Apparatus dimensions in inches are to be regarded as the standard.

1.3 *This standard does not purport to address all of the safety concerns, if any, associated with its use. It is the responsibility of the user of this standard to establish appropriate safety and health practices and determine the applicability of regulatory limitations prior to use.* For specific ~~hazard~~ warning statements, see 8.1-8.4.

### 2. Referenced Documents

2.1 *AFBMA Standard:*

~~AFBMA Standard 19, 1974 (ANSI B. 3.19-1975)~~

AFBMA Standard 19, 1974 (ANSI B. 3.19-1975)<sup>2</sup>

### 3. Terminology

3.1 *Definitions:*

3.1.1 *lubricant, n*—any material interposed between two surfaces that reduces the friction or wear between them.

3.1.2 *lubricating grease, n*—a semi-fluid to solid product of a dispersion of a thickener in a liquid lubricant.

3.1.2.1 *Discussion*—The dispersion of the thickener forms a two-phase system and immobilizes the liquid lubricant by surface tension and other physical forces. Other ingredients are commonly included to impart special properties.

3.1.3 *thickener, n*—*in lubricating grease*, a substance composed of finely-divided particles dispersed in a liquid lubricant to form the product's structure.

3.1.3.1 *Discussion*—The solid thickener can be fibers (such as various metallic soaps) or plates or spheres (such as certain non-soap thickeners) which are insoluble or, at the most, only very slightly soluble in the liquid lubricant. The general requirements are that the solid particles be extremely small, uniformly dispersed, and capable of forming a relatively stable, gel-like structure with the liquid lubricant.

3.2 *Definitions of Terms Specific to This Standard:*

3.2.1 *automotive wheel bearing grease, n*— a lubricating grease specifically formulated to lubricate automotive wheel bearings at relatively high grease temperatures and bearing speeds.

3.2.2 *grease life, n*— *of wheel bearing grease*, amount of time operated under prescribed conditions of load, speed, and temperature until preset torque limit is exceeded.

3.2.2.1 *Discussion*—The *off-time*, which is part of the 20 h and 4 h off-cycle, is not recorded and is not included as part of grease life.

---

<sup>1</sup> This test method is under the jurisdiction of ASTM Committee D02 on Petroleum Products and Lubricants and is the direct responsibility of Subcommittee D02.G0.05 on Lubricating Grease. Functional Tests - Temperature.

Current edition approved Nov. 10, 2002; July 15, 2007. Published February 2003; August 2007. Originally approved in 1976. Last previous edition approved in 1995 as ~~D3527-95~~; D 3527-02.

<sup>2</sup> Available from American National Standards Institute (ANSI), 25 W. 43rd St., 4th Floor, New York, NY 10036.

#### 4. Summary of Test Method

4.1 The test grease is distributed in the bearings of a modified, automobile front wheel hub-spindle-bearings assembly. While the bearings are thrust-loaded to 111 N, the hub is rotated at 1000 rpm and the spindle temperature maintained at 160°C for 20 h, 4 h off operating cycle. The test is terminated when grease deterioration causes the drive motor torque to exceed a calculated motor cut off value. Grease life is expressed as the accumulated on-cycle hours.

#### 5. Significance and Use

5.1 This test method differentiates among wheel bearing greases having distinctly different high-temperature characteristics. It is not the equivalent of ~~long-time~~ longtime service tests, nor is it intended to distinguish between the products having similar high-temperature performance properties.

5.2 This test method has proven to be helpful in screening greases with respect to life performance for automotive wheel bearing applications.

#### 6. Apparatus

6.1 *Test Assembly*<sup>3</sup> (see Fig. 1 and Fig. 2).

6.1.1 *Custom-made Wheel Hub-Spindle-Bearing Assembly* (Fig. 3).

6.1.2 *Oven*, electrically heated by 1800 watt heater, thermostatically controlled to maintain spindle temperature at  $160 \pm 1.5^\circ\text{C}$ .

6.1.3 *Spindle Drive Motor*, 1/4 hp, 120 volts dc with 1725 rpm speed control the hub; motor torque is indicated by a meter equipped with an adjustable, automatic cut-off.

6.1.4 *Fan Drive Motor*, 1/30 hp, 120 v dc, 1550 rpm.

6.2 Motor speed, oven temperature, spindle temperature, time cycles and torque are controlled or monitored, or both, by accessory equipment.

6.3 *Balance* having a minimum capacity of 100 g and minimum sensitivity of 0.1 g.

#### 7. Test Bearings

7.1 Use LM67048-LM67010 and LM11949-LM11910 (AFBMA Standard 19) inboard and outboard bearings,<sup>4</sup> respectively.

#### 8. Reagents and Materials

8.1 *n-Heptane*—reagent grade minimum purity (**Warning**—Flammable. Harmful if inhaled.)

8.2 *Isopropyl Alcohol*—reagent grade minimum purity (**Warning**—Flammable.)

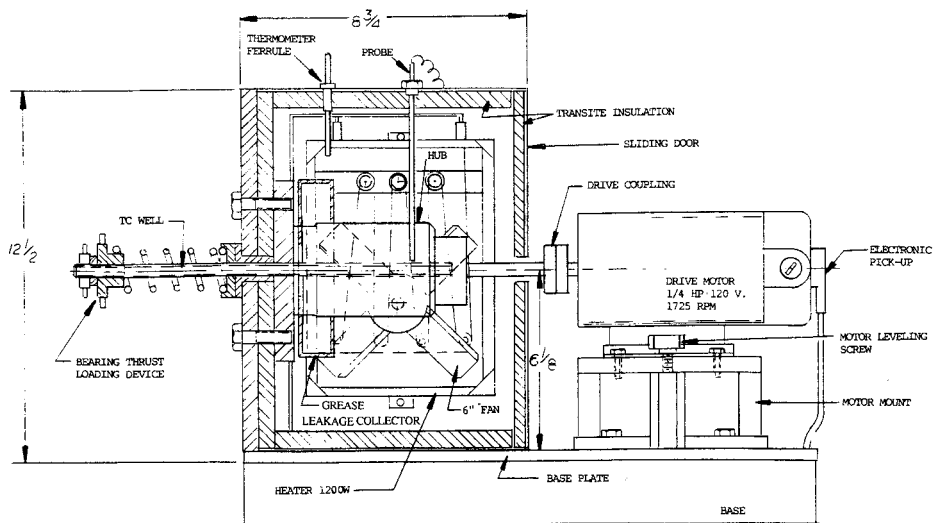

NOTE—Caution should be taken when modifying older units since some may still contain asbestos insulation leading to a possible inhalation hazard.

FIG. 1 Wheel Bearing Lubricant Tester (Elevation View)

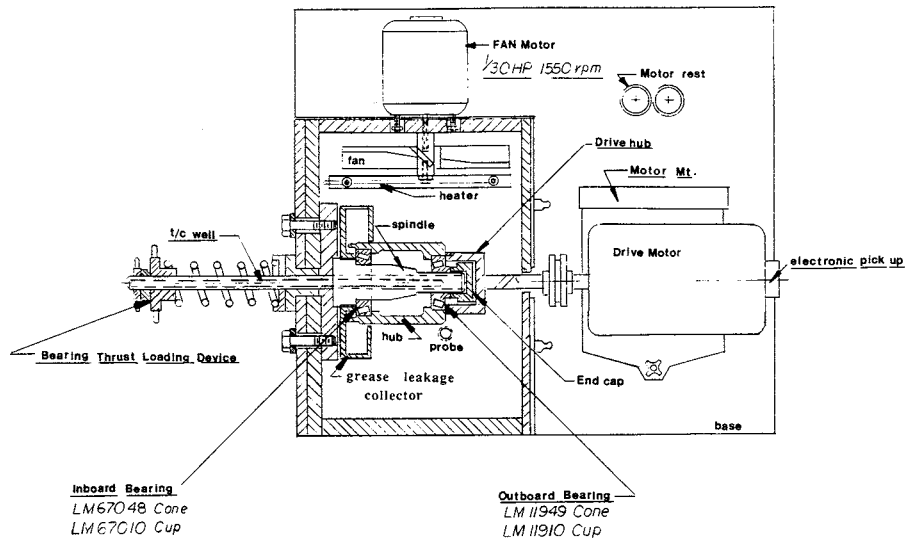

FIG. 2 Wheel Bearing Lubricant Tester (Top View)

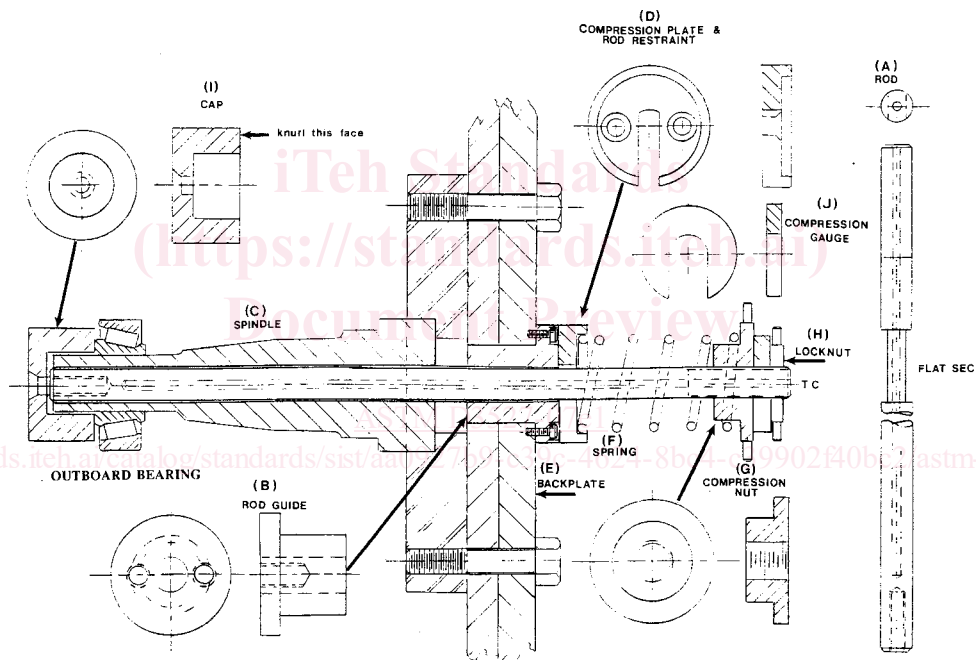

FIG. 3 Spindle and Thrust Rod Components

8.3 ~~Penetone~~Penmul L460 (previously called Penetone ECS)<sup>5</sup>—ECS—(Warning—Combustible. Vapors can be harmful.)

8.4 ~~Stoddard Solvent or Mineral Spirits~~—reagent grade—(Mineral Spirits, Reagent Grade —( Warning—Combustible. Vapors may be harmful.)

8.5 SAE 10W Engine Oil.

8.6 00 Grade Steel Wool.

## 9. Preparation of Bearings

9.1 Carefully remove new bearings (cups and cones) from their packages and place in a suitable clean container. Wash with *n*-Heptane to remove all rust preventative.

9.2 Repeat washing with *n*-Heptane two additional times to be certain all rust preventative has been removed. Use a clean beaker each time.

<sup>5</sup> The sole source of supply of Penmul L460 (previously called Penetone ECS) known to the committee at this time is Penetone Corp., 74 Hudson Ave., Tenafly, NJ 07670. If you are aware of alternative suppliers, please provide this information to ASTM International Headquarters. Your comments will receive careful consideration at a meeting of the responsible technical committee, which you may attend.