



# Standard Specification for Thermoplastic Accessible and Replaceable Plastic Tube and Tubular Fittings<sup>1</sup>

This standard is issued under the fixed designation F409; the number immediately following the designation indicates the year of original adoption or, in the case of revision, the year of last revision. A number in parentheses indicates the year of last reapproval. A superscript epsilon ( $\epsilon$ ) indicates an editorial change since the last revision or reapproval.

*This standard has been approved for use by agencies of the Department of Defense.*

## 1. Scope

1.1 This specification covers requirements and test methods for materials, dimensions and tolerances, hydrostatic pressure, joint integrity, and solvent cement for thermoplastic tube and fittings for accessible and replaceable domestic waste connections. Marking requirements are also included. Plastic which does not meet the material requirements specified in Section 5 is excluded.

1.2 The text of this specification references notes, footnotes, and appendixes which provide explanatory material. These notes and footnotes (excluding those in tables and figures) shall not be considered as requirements of the specification.

1.3 The values stated in inch-pound units are to be regarded as standard. The values given in parentheses are mathematical conversions to SI units that are provided for information only and are not considered standard.

1.4 The following safety hazards caveat pertains only to the test methods portion, Section 8, of this specification: *This standard does not purport to address all of the safety concerns, if any, associated with its use. It is the responsibility of the user of this standard to establish appropriate safety and health practices and determine the applicability of regulatory limitations prior to use.*

## 2. Referenced Documents

### 2.1 ASTM Standards:<sup>2</sup>

- D618 Practice for Conditioning Plastics for Testing
- D1600 Terminology for Abbreviated Terms Relating to Plastics
- D1784 Specification for Rigid Poly(Vinyl Chloride) (PVC) Compounds and Chlorinated Poly(Vinyl Chloride)

<sup>1</sup> This specification is under the jurisdiction of ASTM Committee F17 on Plastic Piping Systems and is the direct responsibility of Subcommittee F17.63 on DWV. Current edition approved Nov. 1, 2008. Published February 2009. Originally approved in 1975. Last previous edition approved in 2002 as F409 – 02. DOI: 10.1520/F0409-02R08.

<sup>2</sup> For referenced ASTM standards, visit the ASTM website, www.astm.org, or contact ASTM Customer Service at service@astm.org. For *Annual Book of ASTM Standards* volume information, refer to the standard's Document Summary page on the ASTM website.

### (CPVC) Compounds

- D2122 Test Method for Determining Dimensions of Thermoplastic Pipe and Fittings
  - D2235 Specification for Solvent Cement for Acrylonitrile-Butadiene-Styrene (ABS) Plastic Pipe and Fittings
  - D2564 Specification for Solvent Cements for Poly(Vinyl Chloride) (PVC) Plastic Piping Systems
  - D2609 Specification for Plastic Insert Fittings for Polyethylene (PE) Plastic Pipe
  - D2657 Practice for Heat Fusion Joining of Polyolefin Pipe and Fittings
  - D2661 Specification for Acrylonitrile-Butadiene-Styrene (ABS) Schedule 40 Plastic Drain, Waste, and Vent Pipe and Fittings
  - D2665 Specification for Poly(Vinyl Chloride) (PVC) Plastic Drain, Waste, and Vent Pipe and Fittings
  - D3965 Classification System and Basis for Specifications for Rigid Acrylonitrile-Butadiene-Styrene (ABS) Materials for Pipe and Fittings
  - D4101 Specification for Polypropylene Injection and Extrusion Materials
  - F402 Practice for Safe Handling of Solvent Cements, Primers, and Cleaners Used for Joining Thermoplastic Pipe and Fittings
  - F412 Terminology Relating to Plastic Piping Systems
  - F1498 Specification for Taper Pipe Threads 60° for Thermoplastic Pipe and Fittings
- ### 2.2 Federal Standard:
- Fed. Std. No. 123 Marking for Shipment (Civil Agencies)<sup>3</sup>
- ### 2.3 Military Standard:
- MIL-STD-129 Marking for Shipment and Storage<sup>3</sup>
- ### 2.4 ANSI/ASME Standard:
- B1.20.1 Pipe Threads, General Purpose (Inch)<sup>4</sup>

<sup>3</sup> Available from Standardization Documents Order Desk, DODSSP, Bldg. 4, Section D, 700 Robbins Ave., Philadelphia, PA 19111-5098, http://www.dodssp.daps.mil.

<sup>4</sup> Available from American National Standards Institute (ANSI), 25 W. 43rd St., 4th Floor, New York, NY 10036, http://www.ansi.org.

**TABLE 1 Dimensions and Tolerances for Outside Diameters and Thickness of Plastic Tube**

Nominal Tube Size	Outside Diameter			Wall Thickness
	Average	Tolerance on Average	Out-of-Roundness (maximum minus minimum)	Minimum
in.	in. (mm)	in. (mm)	in. (mm)	in. (mm)
1¼	1.250 (31.75)	±0.005 (±0.127)	0.020 (0.51)	0.062 (1.575)
1½	1.500 (38.10)	±0.005 (±0.127)	0.020 (0.51)	0.062 (1.575)

## 2.5 Other Document: Uniform Plumbing Code<sup>5</sup>

### 3. Terminology

3.1 *Definitions*—Definitions are in accordance with Terminology **F412**, and abbreviations are in accordance with Terminology **D1600**, unless otherwise specified.

3.1.1 The plumbing terminology used in this specification is in accordance with the definitions given in the Uniform Plumbing Code, unless otherwise indicated.

### 4. Significance and Use

4.1 The requirements of this specification are intended to provide accessible and replaceable tube and fittings to convey domestic waste from fixtures to the drain, waste, and vent (DWV) system.

### 5. Materials and Manufacture

5.1 *Tube*—The tube shall be made of one of the following materials:

5.1.1 Virgin acrylonitrile-butadiene-styrene (ABS) plastic which shall meet the requirements of Specification **D3965**, Cell Classification 4-2-2-2.

5.1.2 Virgin poly(vinyl chloride) (PVC) plastic which shall meet the requirements for 12454C materials in accordance with Specification **D1784**, or

5.1.3 Virgin polypropylene plastic which shall meet the requirements of Specification **D4101**, Cell Classification PP0110B55140 and PP0105G20A33350.

5.2 *Fittings and Mechanical Joint Components*—The fittings and components of mechanical joints shall be comprised of one or more of the following materials:

5.2.1 Virgin ABS plastic which shall meet the requirements of Specification **D3965**, Cell Classification 2-0-2-1-1.

5.2.2 Virgin PVC plastics which shall meet the requirements of 12454C materials as defined in Specification **D1784**, or

5.2.3 Virgin polypropylene plastic which shall meet the requirements of Specification **D4101**, Cell Classification PP0110B55140, and PP0105G20A33350.

5.3 *Rework Material*—The manufacturers shall use only their own clean rework tube and fitting material and the tube or fittings produced shall meet all the requirements of this specification. The different types of material shall not be mixed.

<sup>5</sup> Available from International Association of Plumbing and Mechanical Officials, 5001 E. Philadelphia St., Ontario, CA 91761, <http://www.iapmo.org>.

5.4 *Solvent Cement*—The solvent cement shall meet the requirements of Specification **D2235** or Specification **D2564**. No cement joining of propylene plastic (PP) is permissible.

### 6. Mechanical Connections

6.1 Compression or threaded connections shall incorporate American National Straight Pipe Thread, Mechanical Joints for Fixtures (NPSM). The thread form shall be the form of American National Straight Pipe Thread and the dimensions shall be in accordance with ANSI B1.20.1 (NPSM). All threads shall have a minimum three-thread engagement for fittings and plastic nuts.

6.2 *Taper Pipe Threads*—For all fittings having taper pipe threads, threads shall conform to Specification **F1498** and be gaged in accordance with **8.5**.

6.3 *Straight Pipe Threads (NPSM)*—For all fittings having straight pipe threads, threads shall conform to ANSI B1.20.1 (NPSM) and be gaged in accordance with **8.6**.

6.4 All tube and fittings made from propylene plastic shall be assembled by either mechanical connections or by heat fusion, in accordance with Practice **D2657**.

### 7. Requirements

7.1 *General*—The tube and fittings shall be homogeneous throughout and free of visible cracks, holes, foreign inclusions, or other injurious defects. They shall be as uniform as commercially practicable in color, opacity, density, and other physical properties.

#### 7.2 Dimensions and Tolerances:

##### 7.2.1 Tube:

7.2.1.1 *Tube Dimensions*—The tube dimensions shall meet the requirements given in **Table 1** when measured in accordance with Test Method **D2122**.

7.2.1.2 *Tube Length*—The tolerance on tube lengths is ±¼ in. (±3 mm).

##### 7.2.2 Fittings:

7.2.2.1 *Fitting Dimensions*—The dimensions of fittings shall meet the requirements of **Table 2** when measured in accordance with Test Method **D2122**.

7.2.2.2 *Fitting Laying Length Dimensions*—The laying lengths and other critical dimensions of fittings are shown in **Tables 3-13**.

7.2.2.3 Where applicable for assembly, refer to Table A1.1 in Specification **D2661**, ABS Schedule 40 Fittings.

7.2.2.4 Where applicable for assembly, refer to Table 1 in Specification **D2665**, PVC Schedule 40 Fittings.

TABLE 2 Dimensions and Tolerances for Plastic Tubular Fittings

NOTE 1—Chamfer or flat, optional.  
 NOTE 2—Radius or 45° chamfer, optional.  
 NOTE 3—Radius or chamfer, optional.

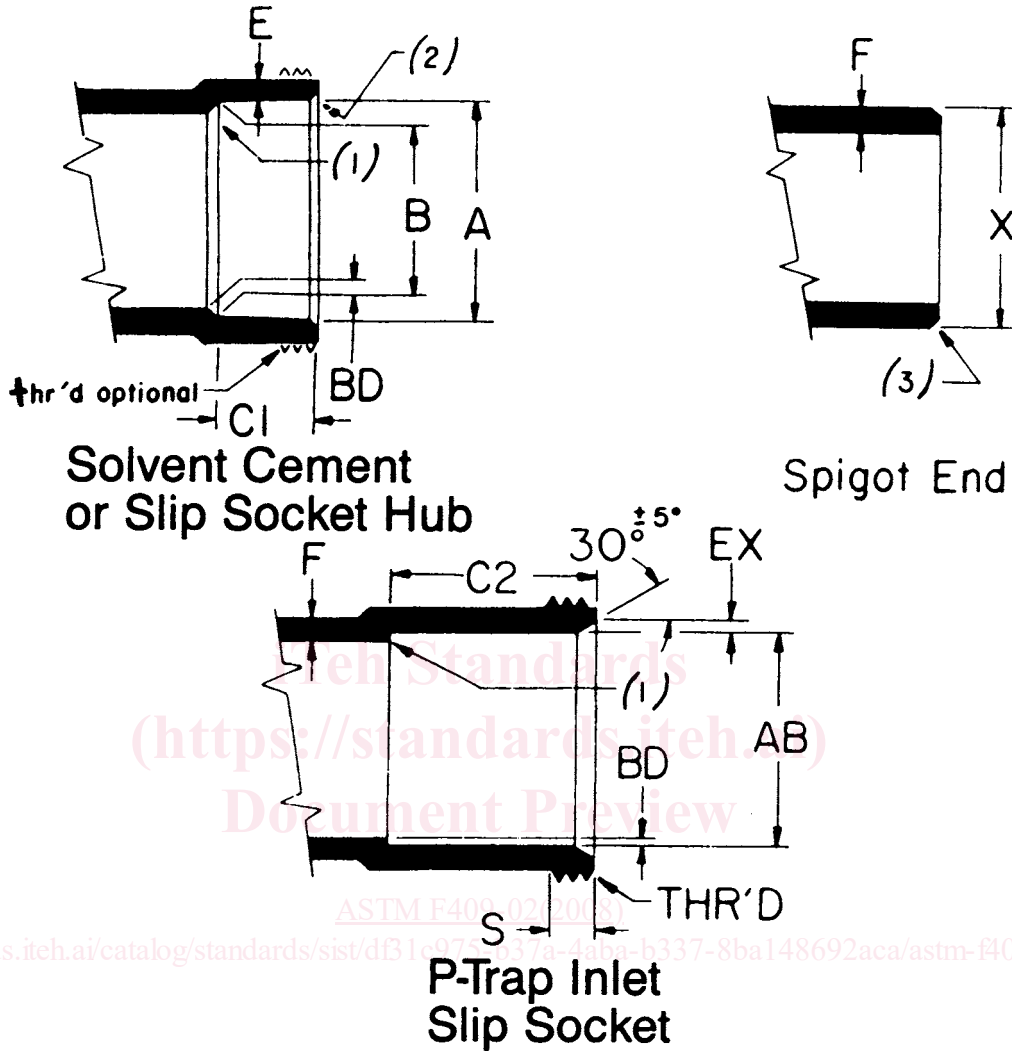

Nominal Tube Size	Thread	A <sup>A</sup>	B <sup>A</sup>	C1	C2	E <sup>B</sup>
in.	in.	±0.005 in. (±0.127 mm)	±0.005 in. (±0.127 mm)	Minimum in. (mm)	Minimum in. (mm)	Minimum in. (mm)
1¼	1¼- 11½ NPSM	1.265 (32.13)	1.250 (31.75)	1¼ <sub>16</sub> (17.46)	1¾ (34.9)	0.062 (1.58)
1½	1½- 11½ NPSM	1.515 (38.48)	1.500 (38.10)	1¼ <sub>16</sub> (17.46)	2 (50.8)	0.062 (1.58)
F <sup>B</sup>	S	X	AB	EX		BD
Minimum in. (mm)	Minimum in. (mm)	±0.005 in. (±0.127 mm)	Minimum in. (mm)	±0.010 in. (±0.254 mm)	Minimum in. (mm)	Maximum in. (mm)
0.062 (1.58)	17/64 (6.75)	1.250 (31.75)	1.258 (31.95)	0.066 (1.68)	0.015 (0.38)	0.070 (1.78)
0.062 (1.58)	17/64 (6.75)	1.500 (38.10)	1.508 (38.30)	0.066 (1.68)	0.015 (0.38)	0.070 (1.78)

<sup>A</sup> Average diameter, the maximum plus minimum diameter divided by 2. The permissible deviation of the diameter from the measured average, often called out-of-roundness, is +0.010 to -0.010 in. (+0.254 to -0.254 mm).  
<sup>B</sup> The wall thickness is a minimum value except that a ±10 % variation resulting from core shift is allowable. In such a case, the average of the two opposite wall thicknesses shall equal or exceed the value shown in the table.

7.3 *Hydrostatic Pressure*—Tube, fittings, and assemblies shall withstand a hydrostatic pressure of 25 psi (170 kPa) when tested in accordance with 8.3.

7.4 *Axial Stress*—Threaded connections shall withstand a minimum axial load of 50 lbf (220 N) when tested in accordance with 8.4.

TABLE 3 Fittings<sup>A</sup>

NOTE 1—Baffle optional.

NOTE 2—See Table 2 for solvent cement or slip socket hub dimensions.

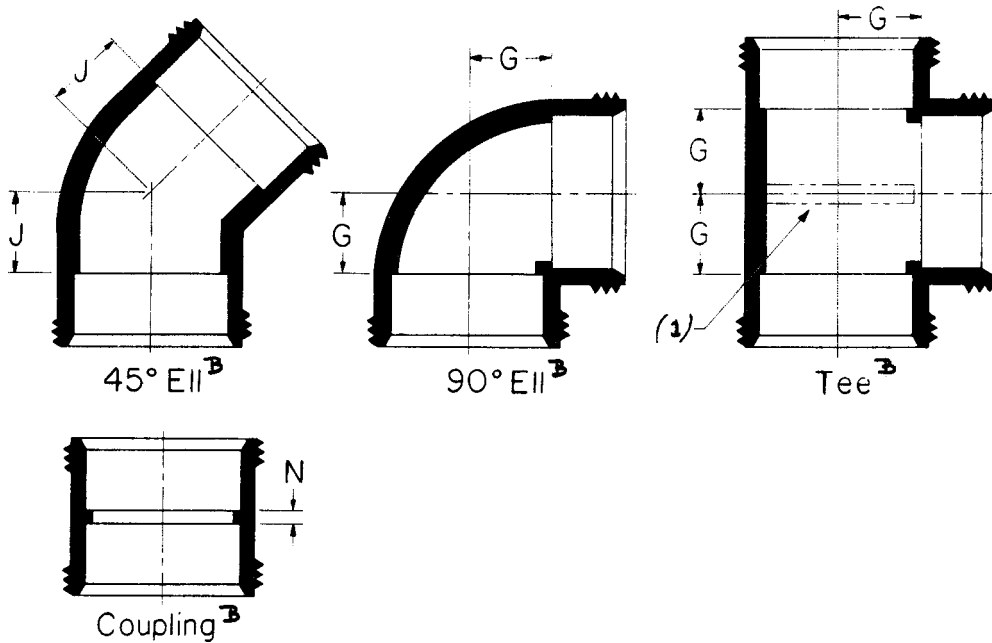

Nominal Tube Size	G	J	N
in.		in. (mm)	
1½	1¾ (20.6)	1¾ (20.6)	¼ (1.6) <sup>B</sup>

<sup>A</sup> All dimensions are minimum.

<sup>B</sup> See Table 2.

8. Test Methods

8.1 Sampling—Take at random a sample of the tube, fittings, or assemblies from each lot or shipment that is sufficient to determine conformance with this specification.

8.2 Conditioning—Unless otherwise specified, condition the specimens prior to test at 70 to 77°F (23 ± 2°C) and 50 ± 5 % relative humidity for not less than 40 h in accordance with Procedure A of Practice D618 for those tests where conditioning is required and in all cases of disagreement.

8.3 Hydrostatic Pressure—Subject the tube and fittings, as an assembly, to an internal hydrostatic pressure of 25 psi (170 kPa) for 1 h. The tube, fittings, and joints shall show no evidence of leaking.

8.4 Axial Stress—Mount threaded connections in a tension-testing machine to apply an axial load. Crosshead speed shall be 0.20 to 0.25 in. (5.0 to 6.3 mm)/min. The connection shall show no evidence of cracking or separation at the minimum load specified in 7.4.

8.5 Taper Pipe Threads—All taper pipe threads shall be gaged in accordance with Specification F1498.

8.6 Straight Pipe Threads (NPSM)—For all fittings having straight pipe threads, threads shall be gaged in accordance with ANSI B1.20.1 (NPSM).

NOTE 1—Some threads listed in Table 6, Table 9, and Table 12 are not listed in ANSI B1.20.1 (NPSM).

9. Retest and Rejection

9.1 If the results of any test(s) do not meet the requirements of this specification, the test(s) shall be conducted again only by agreement between the purchaser and seller. Under such agreement, minimum requirements shall not be lowered, changed, or modified, nor shall specification limits be changed. If upon request, failure occurs, the quantity of product represented by the test(s) does not meet the requirements of this specification.

10. Product Marking

10.1 Tube—The tube shall be marked in letters not less than 1/8 in. (3 mm) high in a contrasting color and shall at least consist of the nominal size, manufacturer’s name or trademark, and “ABS Tubular F409,” “PVC Tubular F409,” or “PP Tubular F409” at intervals of not greater than 2 ft (610 mm).

10.2 Fittings—All fittings shall be marked on the body or hub on both sides. The marking shall consist, at least, of the manufacturer’s name or trademark, the size, and “ABS Tubular F409,” “PVC Tubular F409,” or “P Tubular F409.”

TABLE 4 End Outlet Continuous Waste

- NOTE 1—Radius optional.
- NOTE 2—Baffle optional.
- NOTE 3—Arm shall either be one-piece construction or assembled. If assembled, socket shall conform to Table 2.
- NOTE 4—Shall be swivel nut, slip nut, or slip socket connection (shown in Table 5).
- NOTE 5—Dishwasher branch optional.
- NOTE 6—See Table 6.
- NOTE 7—See Table 2.

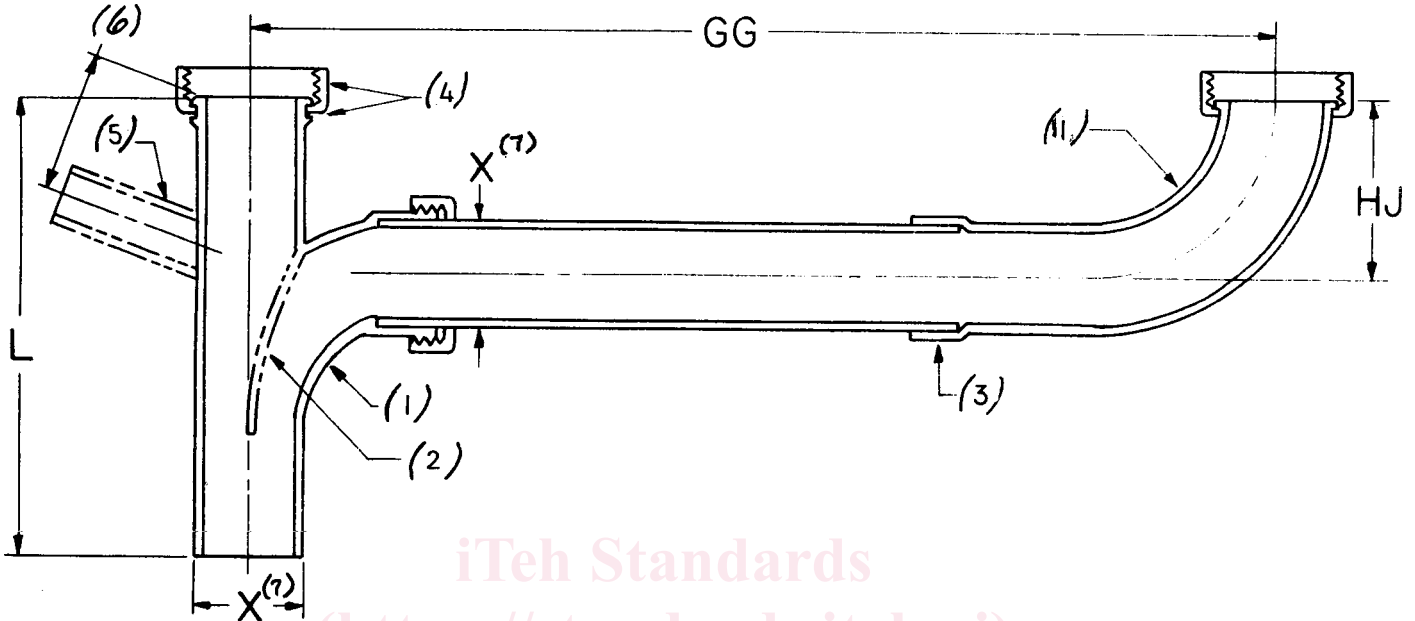

L	HJ	GG			
Minimum in. (mm)	Minimum in. (mm)	Adjustable in four sizes, in. (mm)			
6 (152.4)	1½ (38.1)	12 (305)	16 (406)	21 (533)	25 (635)

TABLE 5 Center Outlet Continuous Waste

- NOTE 1—See Table 2.
- NOTE 2—Radius optional.
- NOTE 3—Baffle optional.
- NOTE 4—Arm shall be either one-piece construction or assembled. If assembled, socket shall conform to Table 2.
- NOTE 5—Shall also be swivel connection as shown in Table 4.

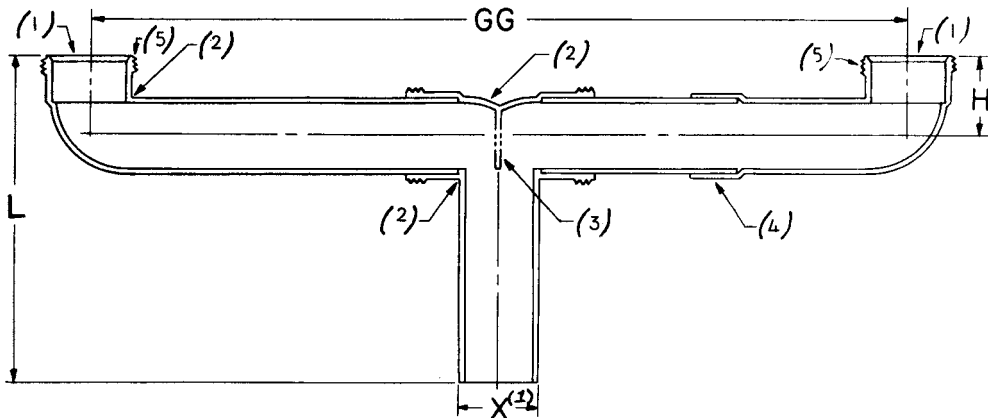

H	L	GG			
Minimum in. (mm)	Minimum in. (mm)	Adjustable in four sizes, in. (mm)			
1½ (38.1)	6 (152.4)	12 (305)	16 (406)	21 (533)	25 (635)

TABLE 6 Dishwasher Branch Tailpiece<sup>A</sup>

NOTE 1—May be swivel or slip connect construction.

NOTE 2—Baffle optional.

NOTE 3—See Table 2.

NOTE 4—See footnote below.<sup>B</sup>

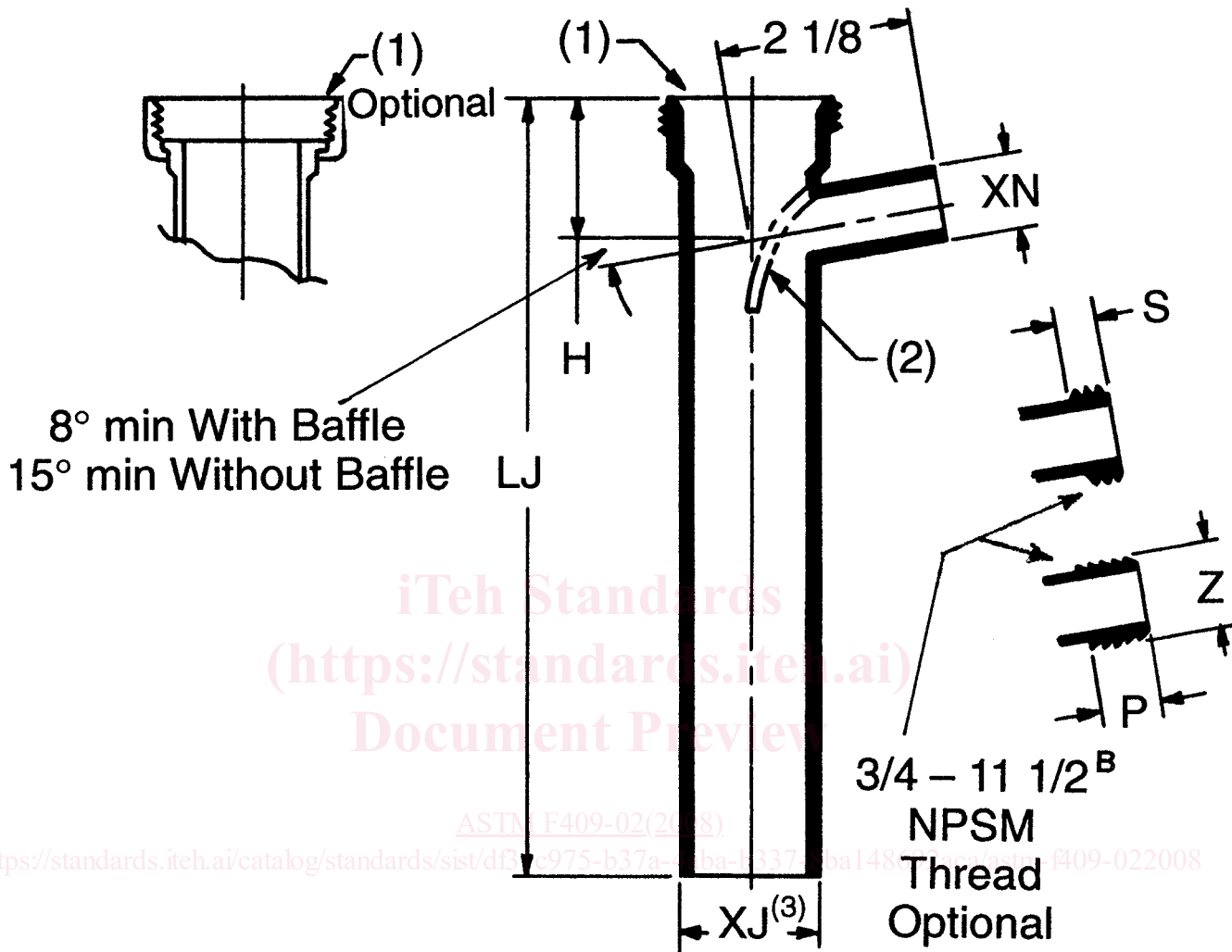

H	P	S	Z	Lj <sup>C</sup>	XN
in. (mm)	in. (mm)	Minimum in. (mm)	in. (mm)	in. (mm)	in. (mm)
1 1/4 (31.8)	1/2 (12.7)	1/4 (6.4)	5/8 (15.9) or 7/8 (22.2)	4 (102) to 24 (610)	5/8 (15.9) or 7/8 (22.2)

<sup>A</sup> All fractional dimensions are minimum.

<sup>B</sup> Threads not listed in ANSI B1.20.1 (NPSM).

<sup>C</sup> Lengths shall be agreed upon between the purchaser and the manufacturer.

10.3 All baffle tees and such fittings as so required shall be marked with arrows indicating the direction of flow when correctly installed.

11. Quality Assurance

11.1 When the product is marked with this designation, F409, the manufacturer affirms that the product was manufac-

tured, inspected, sampled, and tested in accordance with this specification and has been found to meet the requirements of this specification.

12. Keywords

12.1 ABS; cellular; DWV; fittings; pipe; plastic; Schedule 40; thermoplastic