



Designation: F2338 – 09

## Standard Test Method for Nondestructive Detection of Leaks in Packages by Vacuum Decay Method<sup>1</sup>

This standard is issued under the fixed designation F2338; the number immediately following the designation indicates the year of original adoption or, in the case of revision, the year of last revision. A number in parentheses indicates the year of last reapproval. A superscript epsilon ( $\epsilon$ ) indicates an editorial change since the last revision or reapproval.

### 1. Scope

1.1 *Test Packages*—Packages that can be nondestructively evaluated by this test method include:

1.1.1 Rigid and semi-rigid non-lidded trays.

1.1.2 Trays or cups sealed with porous barrier lidding material.

1.1.3 Rigid, nonporous packages.

1.1.4 Flexible, nonporous packages.

1.2 *Leaks Detected*—This test method detects package leaks by measuring the rise in pressure (vacuum loss) in an enclosed evacuated test chamber containing the test package. Vacuum loss results from leakage of test package headspace gases and/or volatilization of test package liquid contents located in or near the leak. When testing for leaks that may be partially or completely plugged with the package's liquid contents, the test chamber is evacuated to a pressure below the liquid's vaporization pressure. All methods require a test chamber to contain the test package and a leak detection system designed with one or more pressure transducers. Test method sensitivities cited below were determined using specific product-package systems selected for the precision and bias studies summarized in **Table 1**. **Table 1** also lists other examples of relevant product-package systems that can be tested for leakage by vacuum decay.

1.2.1 *Trays or Cups (Non-lidded) (Air Leakage)*—Hole or crack defects in the wall of the tray/cup of at least 50  $\mu\text{m}$  in diameter can be detected. Nonlidded trays were tested at a Target Vacuum of  $-4\cdot\text{E}4$  Pa ( $-400$  mbar).

1.2.2 *Trays Sealed with Porous Barrier Lidding Material (Headspace Gas Leakage)*—Hole or crack defects in the wall of the tray/cup of at least 100  $\mu\text{m}$  in diameter can be detected. Channel defects in the seal area (made using wires of 125  $\mu\text{m}$  in diameter) can be detected. Severe seal bonding defects in both continuous adhesive and dot matrix adhesive package systems can be detected. Slightly incomplete dot matrix

adhesive bonding defects can also be detected. All porous barrier lidding material packages were tested at a Target Vacuum of  $-4\cdot\text{E}4$  Pa ( $-400$  mbar). The sensitivity of the test for porous lidded packages is approximately  $\text{E}-2$   $\text{Pa}\cdot\text{m}^3\cdot\text{s}^{-1}$  using a calibrated volumetric airflow meter.

1.2.3 *Rigid, Nonporous Packages (Headspace Gas Leakage)*—Hole defects of at least 5  $\mu\text{m}$  in diameter can be detected. Plastic bottles with screw caps were tested at a target vacuum of  $-5\cdot\text{E}4$  Pa ( $-500$  mbar). Using a calibrated volumetric airflow meter, the sensitivity of the test is approximately  $\text{E}-3.4$   $\text{Pa}\cdot\text{m}^3\cdot\text{s}^{-1}$ . Air-filled glass syringes were tested at a target vacuum of  $-7.5\cdot\text{E}4$  Pa ( $+250$  mbar absolute) and again at a target vacuum of about  $+1$  mbar absolute. The sensitivity of both tests is approximately  $\text{E}-4.1$   $\text{Pa}\cdot\text{m}^3\cdot\text{s}^{-1}$  using a calibrated volumetric airflow meter.

1.2.4 *Rigid, Nonporous Packages (Liquid Leakage)*—Hole defects of at least 5  $\mu\text{m}$  in diameter can be detected. This detection limit was verified using a population of water-filled glass syringes tested at a target vacuum of about  $+1$  mbar absolute.

1.2.5 *Flexible, Nonporous Packages (Gas or Liquid Leakage)*—Such packages may also be tested by the vacuum decay method. Sensitivity data for flexible packages were not included in the precision and bias studies, although the use of vacuum decay for testing such packages is well known.

1.3 *Test Results*—Test results are qualitative (Accept/Reject). Acceptance criteria are established by comparing quantitative baseline vacuum decay measurements obtained from control, non-leaking packages to measurements obtained using leaking packages, and to measurements obtained with the introduction of simulated leaks using a calibrated gas flow meter.

1.4 The values stated in SI units are to be regarded as standard. No other units of measurement are included in this standard.

1.5 *This standard does not purport to address all of the safety concerns, if any, associated with its use. It is the responsibility of the user of this standard to establish appropriate safety and health practices and determine the applicability of regulatory limitations prior to use.*

<sup>1</sup> This test method is under the jurisdiction of ASTM Committee F02 on Flexible Barrier Packaging and is the direct responsibility of Subcommittee F02.40 on Package Integrity.

Current edition approved Jan. 1, 2009. Published February 2009. Originally approved in 2003. Last previous edition approved in 2007 as F2338 – 07. DOI: 10.1520/F2338-09.

**TABLE 1 Summary of Vacuum Decay Leak Tests Applications for Various Product-Packages Systems**

Package Examples <sup>A</sup>	Package Content Examples	ASTM P&B Data Tables	Target Vacuum <sup>B</sup>
<b>GAS LEAK TEST</b>			
<b>PACKAGE APPLICATIONS AND PRECISION &amp; BIAS STUDIES</b>			
Porous barrier lidded trays <sup>C</sup>	Empty Solids (tablets, capsules, powders, devices)	3, 4, 5	-400 mbar
Nonlidded trays <sup>C</sup> or cups	Empty	2	-400 mbar
Plastic screw capped bottles <sup>C</sup>	Solids (tablets, capsules, powders) Liquids (with significant gas headspace volume)	6	-500 mbar
Glass syringes <sup>C</sup>	Solids (lyophilized powders)	7, 8	+250 mbar
<b>ADDITIONAL GAS LEAK TEST PACKAGE APPLICATIONS<sup>A</sup></b>			
Lidded (nonporous) trays or cups containing solid materials (for example, powders, tablets, capsules, devices)			
Glass or plastic vials closed with elastomeric closures containing solid materials (for example, powders)			
Glass or plastic vials closed with elastomeric closures, containing liquid materials, but with significant gas headspace volume			
Flexible packages (for example pouches or bags) containing solid materials (for example, powders, devices)			
<b>LIQUID LEAK TEST (with or without gas headspace)</b>			
<b>PACKAGE APPLICATIONS AND PRECISION &amp; BIAS STUDIES</b>			
Glass syringes <sup>C</sup>	Liquids	9, 10	+1 mbar
<b>ADDITIONAL LIQUID LEAK TEST PACKAGE APPLICATIONS<sup>A</sup></b>			
Ophthalmic dropper tip bottles containing liquid materials			
Glass or plastic ampoules containing liquid materials			
Glass or plastic vials with elastomeric closures containing liquid materials			
Lidded (nonporous) trays or cups) containing liquid materials			
Flexible packages such as pouches or bags containing liquid materials			

<sup>A</sup> Examples of package types relevant to the specified leak test method are listed. The list is not intended to be all inclusive.

<sup>B</sup> Target vacuum expressed as a negative mbar reading (e.g., -400 mbar) refers to the measured test chamber pressure (vacuum) relative to atmospheric pressure. Target vacuum expressed as a positive mbar reading (e.g., +1 mbar) refers to the absolute pressure reading in the test chamber.

<sup>C</sup> Packages used for the referenced ASTM Precision and Bias (P&B) studies.

## 2. Referenced Documents

### 2.1 ASTM Standards:<sup>2</sup>

**D996 Terminology of Packaging and Distribution Environments**

**E691 Practice for Conducting an Interlaboratory Study to Determine the Precision of a Test Method**

**F17 Terminology Relating to Flexible Barrier Packaging**

**F1327 Terminology Relating to Barrier Materials for Medical Packaging** (Withdrawn 2007)<sup>3</sup>

## 3. Terminology

3.1 *Definitions*—For definitions used in this test method, see Terminologies **D996**, **F17**, and **F1327**.

### 3.2 *Definitions of Terms Specific to This Standard:*

3.2.1 *baseline vacuum decay, n*—the extent of vacuum change within the test chamber over time demonstrated by a control, non-leaking package.

3.2.2 *control, non-leaking packages, n*— packages without defects and properly sealed or closed according to manufacturer's specifications.

3.2.3 *flexible, nonporous packages, n*—packages that significantly deflect when under vacuum, and are constructed of malleable, nonporous materials. Examples include pouches or bags made of polymeric, foil, or laminate films.

3.2.4 *gas leaks, n*—leak paths that allow the flow of gas from the test package.

3.2.5 *liquid leaks, n*—leak paths partially or fully filled with liquid.

3.2.6 *rigid, nonporous packages, n*—packages that do not significantly deflect under vacuum and are constructed of solid, nonporous materials. Examples include plastic bottles with screw-thread or snap-on closures, glass or plastic vials with elastomeric closures, and glass or plastic syringes.

3.2.7 *semi-rigid trays or cups, n*—trays made of material that retain shape upon deflection. For example, thermoformed PETE or PETG trays are considered semi-rigid trays.

3.2.8 *spotty or mottled seals, n*—an incomplete adhesive bond made between a package tray or cup and porous lidding material that can be visibly identified by a distinctive pattern of dots, spotting or mottling on the tray sealing surface after the lid is removed.

3.2.9 *volumetric airflow meter, n*—a calibration tool that can be used to provide an artificial leak of known volumetric airflow rate into the test chamber for verification of instrument sensitivity. Airflow meters should be calibrated to NIST standards. The operational range of the meter should reflect the desired limit of sensitivity for the intended leak test.

3.3 *Definitions of Test Cycle and Critical Parameters Terms*—For terms and abbreviations relating to the test cycle and the critical parameters for establishing accept/reject limits, see **Annex A1**.

## 4. Summary of Test Method

4.1 The test package is placed in a test chamber to which vacuum is applied. The chamber is then isolated from the

<sup>2</sup> For referenced ASTM standards, visit the ASTM website, [www.astm.org](http://www.astm.org), or contact ASTM Customer Service at [service@astm.org](mailto:service@astm.org). For *Annual Book of ASTM Standards* volume information, refer to the standard's Document Summary page on the ASTM website.

<sup>3</sup> The last approved version of this historical standard is referenced on [www.astm.org](http://www.astm.org).

vacuum source and a pressure transducer (absolute or gauge) alone or in combination with a second differential pressure transducer, is used to monitor the test chamber for both the level of vacuum, as well as the change in vacuum over time. Vacuum decay, or rise in chamber pressure, is a result of package headspace gas being drawn out of the package through any leaks present, plus background noise. Vacuum decay can also result from the volatilization of packaged liquid that partially or fully occludes the leak path. In this case, vacuum decay will only occur if the chamber test pressure is lowered below the liquid's vaporization pressure.

4.2 Porous barrier lidded tray or cup packages are tested for leaks located in the tray or cup, and at the lidding material/tray seal junction. Leaks in the porous lidding material itself cannot be detected. When testing such packages, steps are taken to physically mask or block the porous barrier surface to prevent the migration of package gas through the porous lid. These steps may require some sample preparation, depending on the masking approach required, but must be nondestructive and noninvasive. Vacuum decay from porous barrier lidded packages may potentially include background noise from gas trapped between the lidding material and the masking surface, or from transverse gas flow through the porous barrier material itself at the lid/tray seal junction.

4.3 The sensitivity of a test is a function of test package design, transducer(s)'sensitivity, test chamber design, test system design, and critical test parameters of time and pressure. The test system and leak test parameters selected for any given product-package system must be based on the package's contents (liquid or solid with significant or little gas headspace), and the nature of the package (flexible or rigid, porous or nonporous). Instruments with more sensitive pressure transducers and with minimal void volumes within the test chamber and the test system have the potential to detect the smallest leaks. Lengthening test time enables smaller gaseous leaks to be detected. Minimizing pressure variation background noise can also improve test sensitivity. For porous barrier lidded packages, masking techniques will minimize background noise. For flexible or semi-rigid packages, restricting package expansion via properly designed test chambers lessens noise. Background noise may also occur upon release of residual gases or vapors trapped in the test system or between test package components. Such noise can be differentiated from actual leakage by lengthening the time to reach initial vacuum or lengthening equalization time.

NOTE 1—Further information on the “Leak Test Theory” may be found in **Annex A1**. Examples of test methods and test equipment used to generate the precision and bias data in Section 12 are summarized in **Table 1**.

## 5. Significance and Use

5.1 Leaks in medical device, pharmaceutical, and food packages may result in the ingress of unwanted gases (most commonly oxygen), harmful microbiological, or particulate contaminants. Package leaks may appear as imperfections in the package components themselves or at the seal juncture between mated components. The ability to detect leaks is necessary to ensure consistency and integrity of packages.

5.2 After initial set-up and calibration, individual test operation may be semi-automatic, automatic, or manual. The test method permits non-destructive detection of leaks not visibly detectable. The test method does not require the introduction of any extraneous materials or substances, such as dyes or gases. However, it is important to physically mask or block off any package porous barrier surface during the test to prevent rapid loss of chamber vacuum resulting primarily from gas migration through the porous surface. Leak detection is based solely on the ability to detect the change in pressure inside the test chamber resulting from gas or vapor egress from a package challenged with vacuum.

5.3 This test is a useful research tool for optimizing package sealing parameters and for comparatively evaluating various packages and materials. This test method is also applicable to production settings as it is rapid, non-invasive, and non-destructive, making it useful for either 100 % on-line testing or to perform tests on a statistical sampling from the production operation.

5.4 Leak test results that exceed the permissible limits for the vacuum decay test are indicated by audible or visual signal responses, or both.

## 6. Apparatus

6.1 *Vacuum Decay Leak Detection Apparatus*—The vacuum decay leak apparatus includes a test chamber connected to a vacuum decay test system and a volumetric airflow meter.

6.2 *Test Chamber*—The test chamber has a lower compartment (lower tooling) designed to nest the test package, and an upper lid (top tooling) for closing the test chamber. **Fig. 1** illustrates a test chamber designed for testing packages with porous barrier lidding material. The test fixture upper lid consists of a flexible bladder to mask the package's porous barrier during the test cycle. **Figs. 2 and 3** illustrate test chambers designed for testing rigid, nonporous packages. In the latter two cases, there is no flexible bladder.

6.2.1 *Tray Nest or Lower Tooling*—The bottom half of the test chamber is dimensionally designed to closely nest the test package, while still allowing for easy gas flow around the test package. Without ready gas flow around the package, leakage sites can be blocked. Conversely, the larger the gap between the test chamber and the test package, the less sensitive the leak test, as vacuum decay from package leakage will be minimized in a larger net test chamber volume.

6.2.2 *Upper Lid or Upper Tooling*—The upper lid is designed to tightly seal the closed test chamber during the vacuum cycle.

6.3 *Vacuum Decay Test System*—The vacuum decay test system includes a vacuum source for establishing the required vacuum within the chamber at the beginning of the test cycle, and a pressure transducer (absolute or gauge), alone or in combination with a second differential pressure transducer, for monitoring the vacuum level as well as the pressure change as a function of time during the test cycle. Test systems intended for higher target vacuums, such as +1 mbar or less, should be designed for greater target pressure measurement accuracy,

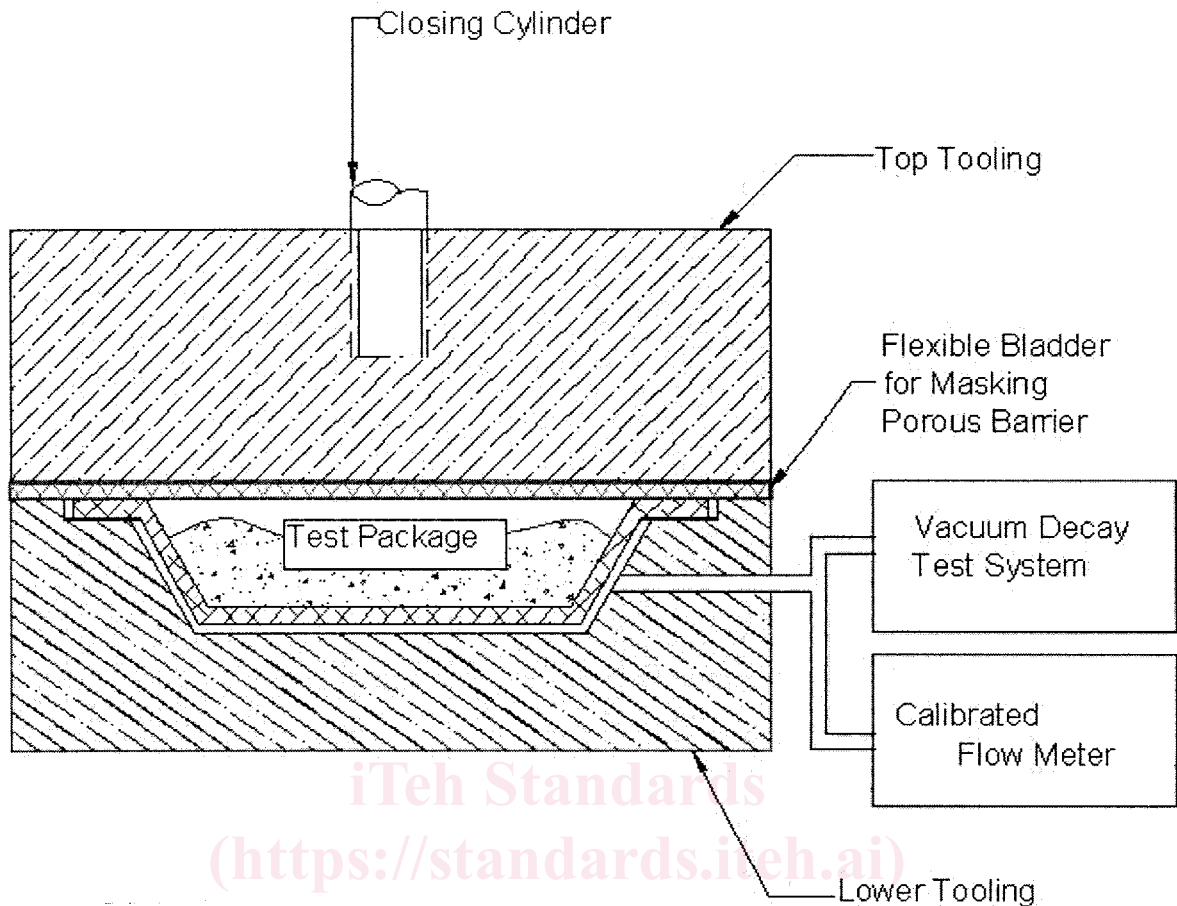

FIG. 1 Schematic of Fixture and Porous Barrier Lidded Test Package

with minimal system leakage and outgassing that may affect test measurement signal to noise ratio.

NOTE 2—Different leak test instruments may utilize different pressure transducer types and combinations, and vacuum pumps based on the package types tested (for example, rigid versus nonrigid, porous versus nonporous) and the vacuum level that is required to perform the test.

6.3.1 *Absolute versus Gauge Transducer*—All instruments includes a single 1000 Torr transducer for monitoring test pressure throughout the test cycle. An absolute transducer is preferred over a gauge transducer when precise, true pressure readings are required (that is, not subject to atmospheric pressure changes from weather or altitude). Such is the case when performing high vacuum liquid leak tests.

6.3.2 *Differential Transducer*—A second differential pressure transducer may be employed for measuring the smallest detectable leaks in rigid or semi-rigid nonporous packages.

6.3.3 *Vacuum Source*—A vacuum pump is selected based on the target vacuum level that must be achieved within the allotted time frame given the test system airspace.

6.4 *Mask or Block*—The porous barrier lidding material of packages must be masked or blocked during testing to minimize egress of air from the package through the lidding. Various masking techniques may be used, including a test chamber designed with a flexible bladder in the upper tooling (refer to Fig. 1).

6.5 *Volumetric Airflow Meter*—An adjustable volumetric airflow meter is placed in-line with the test chamber to introduce an artificial leak at variable rates. It is recommended that an airflow meter be used to verify the leak test's sensitivity.

NOTE 3—Refer to Annex A2 for further information about volumetric airflow meter use for verifying leak test sensitivity.

## 7. Hazards

7.1 As the test chamber is closed, it may present pinch-point hazards.

## 8. Preparation of Apparatus

8.1 The test apparatus must be started, warmed-up, and made ready according to the manufacturer's specifications. For those instruments that rely on an internal, air-driven vacuum pump, the utilities required for instrument operation include electrical power and a dry, non-lubricated compressed air supply, according to manufacturer's specifications. For those instruments that rely on an external vacuum pump, the utilities required for instrument operation include electrical power according to manufacturer's specifications for both the instrument and the vacuum pump.

## 9. Calibration and Standardization

9.1 Before test measurements are made, the apparatus must be calibrated. The pressure transducers, any applicable vacuum



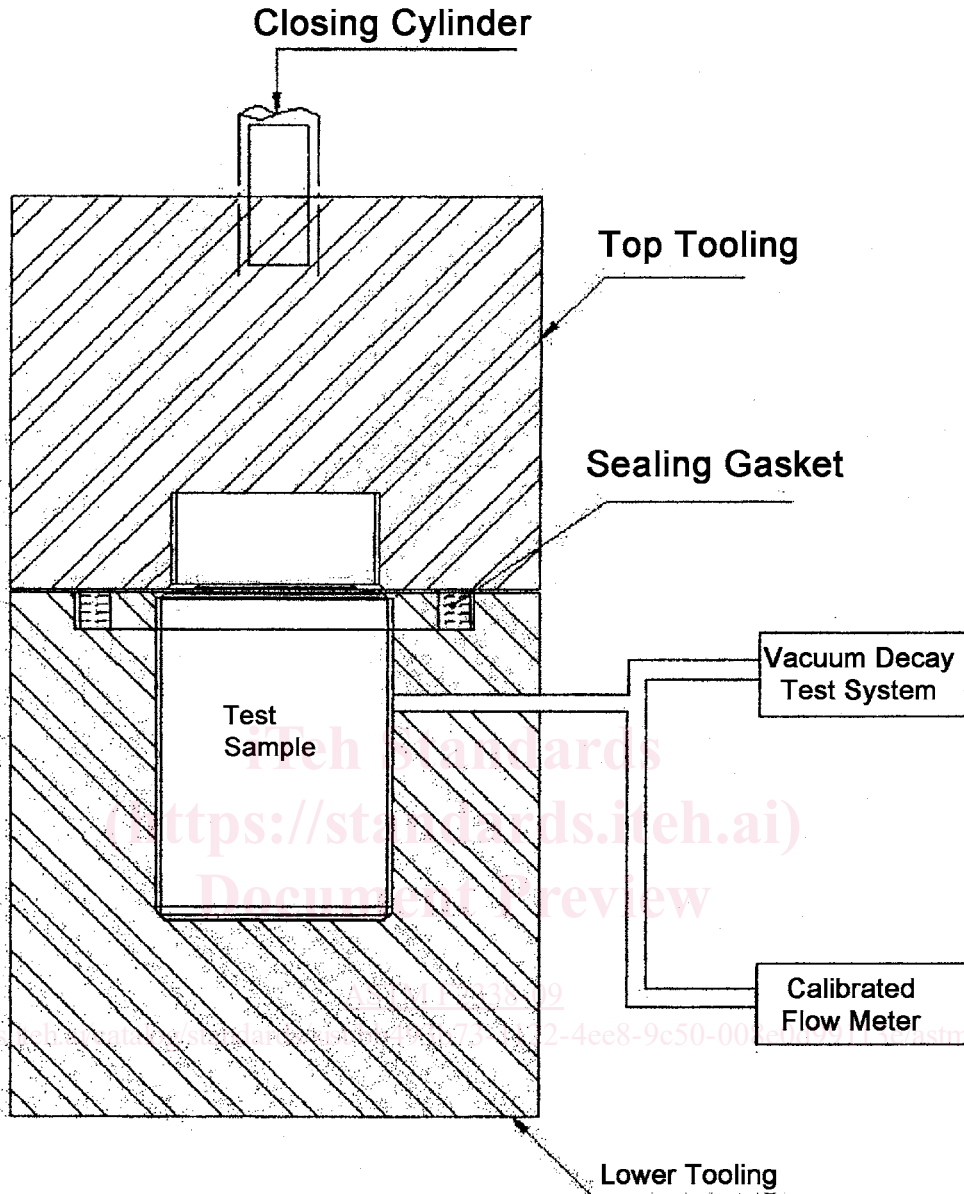

FIG. 2 Schematic of Fixture and Rigid, Nonporous Test Package

source pressure gauges, and the adjustable volumetric airflow meter must all be calibrated according to the manufacturer's recommended procedures and maintenance schedule.

9.2 Leak tests should be performed on the instrument test system to verify a steady baseline leak rate. The test parameters for start-up system qualification tests are typically recommended by the instrument manufacturer.

9.3 Critical test parameter settings must be established for each package/test fixture combination. Parameters will vary based on the test package geometry and any porous barrier surface's inherent porosity. A few control non-leaking packages or a no-leak package mock-up must be used to select critical test parameter settings.

NOTE 4—Refer to Section 4 and Annex A1 for a description of critical test parameters.

9.4 A larger sample population of control non-leaking packages must be used for optimizing critical test parameters. Control packages are to be made from the same materials and according to the same design as the test units.

NOTE 5—Refer to Annex A2 for information on critical test parameter selection.

9.5 Determine the sensitivity of the optimized leak test using control non-leaking test packages and a calibrated volumetric airflow meter.

NOTE 6—Refer to Annex A2 for information about test sensitivity verification procedures.

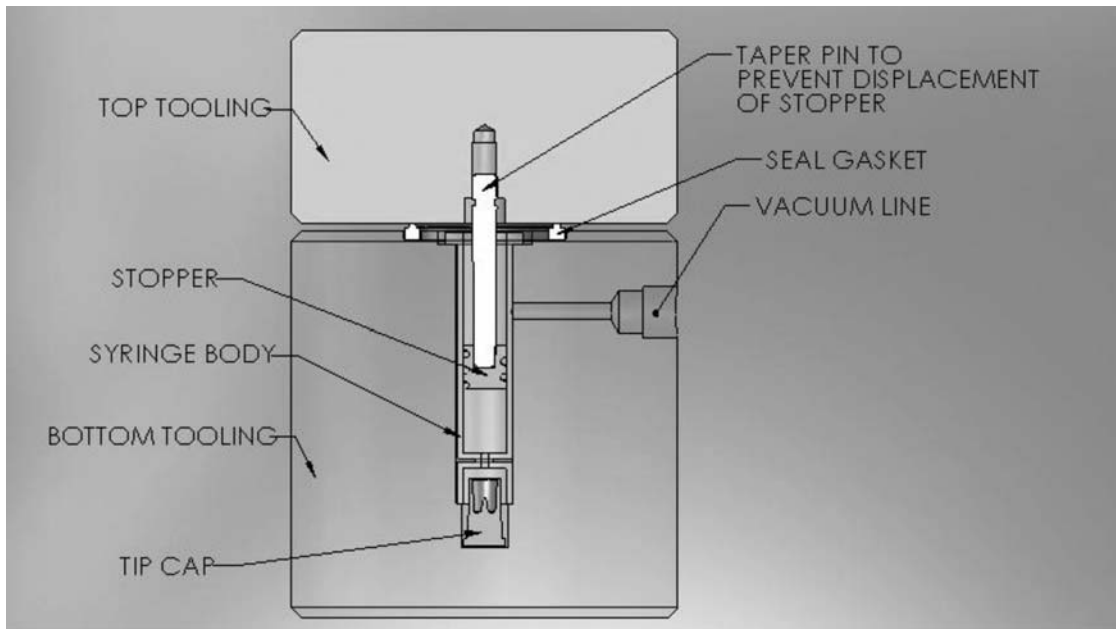

FIG. 3 Schematic of Test Chamber and Rigid, Nonporous Test Package

9.6 Qualify the ability of the optimized test to reliably differentiate between known non-leaking and defective packages.

9.7 Test system baseline qualification (see 9.2) and test sensitivity verification (see 9.5) are to be conducted frequently, typically at least one or more times a day, preferably at the beginning of every shift.

**10. Procedure**

10.1 Select and install the appropriately sized test chamber for the package to be tested. Make any necessary adjustments to the chamber to ensure a sufficiently tight seal of the chamber lid (upper tooling) to the lower chamber package nest (lower tooling) when the test chamber is in the closed position.

10.2 Verify the pressure level available at the supply source. Check the functionality of the vacuum source.

10.3 Program the test instrument with all necessary test parameters and accept/reject criteria.

10.4 For those test methods that require a Pre-Test Vacuum sequence prior to each test sample leak test, close the empty test chamber and perform the required timed vacuum sequence.

10.5 Place the assembled package into the lower tooling nest and close the test chamber. Take appropriate steps to mask or block any porous barrier surface of the package.

NOTE 7—Inspect and clean the masking or blocking surface according to a regularly established routine according to the instrument manufacturer’s recommended procedures to ensure effective masking of the porous barrier surface.

10.6 Start the test.

10.7 Note the pass or fail indicator or other means of detecting vacuum decay and document results. Identify and set aside any failed package for further evaluation.

10.7.1 If suspect fail results occur, verify the test chamber and system functionality according to the leak test instrument manufacturer’s instructions prior to proceeding.

10.7.2 If a failed test package contains product that may have contaminated the test chamber or system during the leak test, perform steps to eliminate the contaminant from the test chamber or system according to the leak test instrument manufacturer’s instructions prior to proceeding.

10.8 Select another package and repeat the testing process.

**11. Report**

11.1 For each package tested, report the values for the following critical test parameters as well as package test results:

11.1.1 Pre-Test Vacuum expressed in seconds.

11.1.2 Reserve Vacuum expressed in mbar or Pa, in either positive absolute pressure units or negative pressure units (vacuum) relative to atmospheric pressure.

11.1.3 Target Vacuum expressed in mbar or Pa, in either positive absolute pressure units or negative pressure units (vacuum) relative to atmospheric pressure.

11.1.4 Reference Vacuum expressed in mbar or Pa, in either positive absolute pressure units or negative pressure units (vacuum) relative to atmospheric pressure.

11.1.5 Reference Fill Time expressed in seconds.

11.1.6 Equalization Time expressed in seconds.

11.1.7 Test Time expressed in seconds.

11.1.8 Reference Vacuum Decay Accept/Reject Limit expressed in Pa/s or Pa, in either positive absolute pressure units to describe allowable pressure rise, or negative pressure units (vacuum) to describe allowable vacuum loss.

11.1.9 Accept/Reject Test Results.