

ETSI TS 138 509 V15.13.0 (2022-08)



**5G;
LTE;
5GS;**
**Special conformance testing functions
for User Equipment (UE)
(3GPP TS 38.509 version 15.13.0 Release 15)**



Reference

RTS/TSGR-0538509vfd0

Keywords

5G,LTE

ETSI

650 Route des Lucioles
F-06921 Sophia Antipolis Cedex - FRANCE

Tel.: +33 4 92 94 42 00 Fax: +33 4 93 65 47 16

Siret N° 348 623 562 00017 - APE 7112B
Association à but non lucratif enregistrée à la
Sous-Préfecture de Grasse (06) N° w061004871

Important notice

The present document can be downloaded from:

<http://www.etsi.org/standards-search>

The present document may be made available in electronic versions and/or in print. The content of any electronic and/or print versions of the present document shall not be modified without the prior written authorization of ETSI. In case of any existing or perceived difference in contents between such versions and/or in print, the prevailing version of an ETSI deliverable is the one made publicly available in PDF format at www.etsi.org/deliver.

Users of the present document should be aware that the document may be subject to revision or change of status.

Information on the current status of this and other ETSI documents is available at

<https://portal.etsi.org/TB/ETSIDeliverableStatus.aspx>

If you find errors in the present document, please send your comment to one of the following services:

<https://standards.iteh.ai> <https://portal.etsi.org/People/CommitteeSupportStaff.aspx> 7-0abc5f83ea90/etsi-

If you find a security vulnerability in the present document, please report it through our

Coordinated Vulnerability Disclosure Program:

<https://www.etsi.org/standards/coordinated-vulnerability-disclosure>

Notice of disclaimer & limitation of liability

The information provided in the present deliverable is directed solely to professionals who have the appropriate degree of experience to understand and interpret its content in accordance with generally accepted engineering or other professional standard and applicable regulations.

No recommendation as to products and services or vendors is made or should be implied.

No representation or warranty is made that this deliverable is technically accurate or sufficient or conforms to any law and/or governmental rule and/or regulation and further, no representation or warranty is made of merchantability or fitness for any particular purpose or against infringement of intellectual property rights.

In no event shall ETSI be held liable for loss of profits or any other incidental or consequential damages.

Any software contained in this deliverable is provided "AS IS" with no warranties, express or implied, including but not limited to, the warranties of merchantability, fitness for a particular purpose and non-infringement of intellectual property rights and ETSI shall not be held liable in any event for any damages whatsoever (including, without limitation, damages for loss of profits, business interruption, loss of information, or any other pecuniary loss) arising out of or related to the use of or inability to use the software.

Copyright Notification

No part may be reproduced or utilized in any form or by any means, electronic or mechanical, including photocopying and microfilm except as authorized by written permission of ETSI.

The content of the PDF version shall not be modified without the written authorization of ETSI.

The copyright and the foregoing restriction extend to reproduction in all media.

© ETSI 2022.
All rights reserved.

Intellectual Property Rights

Essential patents

IPRs essential or potentially essential to normative deliverables may have been declared to ETSI. The declarations pertaining to these essential IPRs, if any, are publicly available for **ETSI members and non-members**, and can be found in ETSI SR 000 314: "*Intellectual Property Rights (IPRs); Essential, or potentially Essential, IPRs notified to ETSI in respect of ETSI standards*", which is available from the ETSI Secretariat. Latest updates are available on the ETSI Web server (<https://ipr.etsi.org/>).

Pursuant to the ETSI Directives including the ETSI IPR Policy, no investigation regarding the essentiality of IPRs, including IPR searches, has been carried out by ETSI. No guarantee can be given as to the existence of other IPRs not referenced in ETSI SR 000 314 (or the updates on the ETSI Web server) which are, or may be, or may become, essential to the present document.

Trademarks

The present document may include trademarks and/or tradenames which are asserted and/or registered by their owners. ETSI claims no ownership of these except for any which are indicated as being the property of ETSI, and conveys no right to use or reproduce any trademark and/or tradename. Mention of those trademarks in the present document does not constitute an endorsement by ETSI of products, services or organizations associated with those trademarks.

DECT™, **PLUGTESTS™**, **UMTS™** and the ETSI logo are trademarks of ETSI registered for the benefit of its Members. **3GPP™** and **LTE™** are trademarks of ETSI registered for the benefit of its Members and of the 3GPP Organizational Partners. **oneM2M™** logo is a trademark of ETSI registered for the benefit of its Members and of the oneM2M Partners. **GSM®** and the GSM logo are trademarks registered and owned by the GSM Association.

Legal Notice

This Technical Specification (TS) has been produced by ETSI 3rd Generation Partnership Project (3GPP).

The present document may refer to technical specifications or reports using their 3GPP identities. These shall be interpreted as being references to the corresponding ETSI deliverables.

The cross reference between 3GPP and ETSI identities can be found under <http://webapp.etsi.org/key/queryform.asp>.

Modal verbs terminology

In the present document "**shall**", "**shall not**", "**should**", "**should not**", "**may**", "**need not**", "**will**", "**will not**", "**can**" and "**cannot**" are to be interpreted as described in clause 3.2 of the [ETSI Drafting Rules](#) (Verbal forms for the expression of provisions).

"**must**" and "**must not**" are **NOT** allowed in ETSI deliverables except when used in direct citation.

Contents

Intellectual Property Rights	2
Legal Notice	2
Modal verbs terminology.....	2
Foreword.....	5
1 Scope	6
2 References	6
3 Definitions, symbols and abbreviations	7
3.1 Definitions	7
3.2 Symbols.....	8
3.3 Abbreviations	8
4 UE special conformance test functions overview	8
4.1 Requirements for UE support of test functions	8
4.2 UE special conformance test functions concept	8
5 UE special conformance test functions operation	9
5.1 General	9
5.2 Activation and deactivation of 5GS test mode bearers (UE test mode procedures)	10
5.2.1 General.....	10
5.2.2 Activate UE test mode	10
5.2.3 Deactivate UE test mode.....	10
5.3 Test loop functions	10
5.3.1 General.....	10
5.3.2 Close UE test loop	11
5.3.3 Open UE test loop.....	11
5.3.4 UE functionality when test loop is closed.....	11
5.3.4.1 UE test loop mode A operation	11
5.3.4.2 UE test loop mode B operation	16
5.3.4.2.1 General	16
5.3.4.2.2 UE test loop mode B operation for EN-DC and NGEN-DC	17
5.3.4.2.3 UE test loop mode B operation for Standalone NR.....	19
5.3.4.2.4 UE test loop mode B operation for NE-DC.....	21
5.4 UE Beamlock test Function (UBF)	24
5.4.1 General.....	24
5.4.2 Activate Beamlock procedure.....	24
5.4.2.1 Initiation.....	24
5.4.2.2 Reception of ACTIVATE BEAMLOCK message by UE	24
5.4.3 Deactivate Beamlock procedure	25
5.4.3.1 Initiation.....	25
5.4.3.2 Reception of DEACTIVATE BEAMLOCK message by UE	25
5.4.3.3 Release of antenna beamlock by UE.....	25
5.5 UE SS-RSRPB per receiver branch reporting	25
5.5.1 General.....	25
5.5.2 Initiation.....	26
5.5.3 Reception of SS-RSRPB REPORT REQUEST message by UE.....	26
5.6 UE Positioning test mode procedures.....	27
5.6.1 Reset UE Positioning Stored Information.....	27
5.6.1.1 General	27
5.6.1.2 Initiation.....	27
5.6.1.3 Reception of RESET UE POSITIONING STORED INFORMATION message by UE.....	27
5.6.2 Update UE Location Information	28
5.6.2.1 General	28
5.6.2.2 Initiation.....	28
5.6.3 UTC time reset.....	28
5.7 NSSAI delete test function	28

5.7.1	General.....	28
6	Test Mode Control message definitions.....	30
6.1	General	30
6.2	Test mode messages	30
6.2.1	ACTIVATE TEST MODE	30
6.2.2	ACTIVATE TEST MODE COMPLETE	30
6.2.3	DEACTIVATE TEST MODE.....	30
6.2.4	DEACTIVATE TEST MODE COMPLETE.....	30
6.3	Test loop messages.....	30
6.3.1	CLOSE UE TEST LOOP	30
6.3.2	CLOSE UE TEST LOOP COMPLETE.....	31
6.3.3	OPEN UE TEST LOOP	31
6.3.4	OPEN UE TEST LOOP COMPLETE.....	31
6.3.5	Void	31
6.3.6	Void	31
6.4	Beamlock messages.....	31
6.4.1	ACTIVATE BEAMLOCK	31
6.4.2	ACTIVATE BEAMLOCK COMPLETE	32
6.4.3	DEACTIVATE BEAMLOCK.....	32
6.4.4	DEACTIVATE BEAMLOCK COMPLETE.....	32
6.5	UE SS-RSRP per receiver branch reporting messages.....	33
6.5.1	SS-RSRPB REPORT REQUEST	33
6.5.2	SS-RSRPB REPORT RESPONSE	33
6.6	UE Positioning messages	34
6.6.1	RESET UE POSITIONING STORED INFORMATION	34
6.6.2	UPDATE UE LOCATION INFORMATION	34
6.7	NSSAI delete messages.....	34
6.7.1	NSSAI DELETE REQUEST.....	34
6.7.2	NSSAI DELETE RESPONSE.....	36
7	Variables, constants and timers	36
7.1	State variables	36
7.2	Constants	36
7.3	Timers	36
7.4	Configurable parameters	36
8	Electrical Man Machine Interface (EMMI).....	36
Annex A (informative): Change history		38
History		39

Foreword

This Technical Specification has been produced by the 3rd Generation Partnership Project (3GPP).

The contents of the present document are subject to continuing work within the TSG and may change following formal TSG approval. Should the TSG modify the contents of the present document, it will be re-released by the TSG with an identifying change of release date and an increase in version number as follows:

Version x.y.z

where:

- x the first digit:
 - 1 presented to TSG for information;
 - 2 presented to TSG for approval;
 - 3 or greater indicates TSG approved document under change control.
- y the second digit is incremented for all changes of substance, i.e. technical enhancements, corrections, updates, etc.
- z the third digit is incremented when editorial only changes have been incorporated in the document.

iTeh STANDARD PREVIEW
(standards.iteh.ai)

[ETSI TS 138 509 V15.13.0 \(2022-08\)](https://standards.iteh.ai/catalog/standards/sist/fb1d7335-dd0f-49e8-9ee7-0abc5f83ea90/etsi-ts-138-509-v15-13-0-2022-08)

<https://standards.iteh.ai/catalog/standards/sist/fb1d7335-dd0f-49e8-9ee7-0abc5f83ea90/etsi-ts-138-509-v15-13-0-2022-08>

1 Scope

The present document defines for User Equipment (UE) those special functions and their activation/deactivation methods that are required in the UE for conformance testing purposes when the UE is connected to the 5G System (5GS) via its radio interface(s).

The document also describes the operation of these special functions when the 5GS capable UEs are connected via a non-5GS system e.g. E-UTRA FDD or TDD system.

Depending on the 5GS system's architecture some relevant for the UE for conformance testing special functions may be defined in TS 36.509 [6].

2 References

The following documents contain provisions which, through reference in this text, constitute provisions of the present document.

References are either specific (identified by date of publication, edition number, version number, etc.) or non-specific.

- For a specific reference, subsequent revisions do not apply.
- For a non-specific reference, the latest version applies. In the case of a reference to a 3GPP document (including a GSM document), a non-specific reference implicitly refers to the latest version of that document *in the same Release as the present document* unless the context in which the reference is made suggests a different Release is relevant (information on the applicable release in a particular context can be found in e.g. test case title, description or applicability, message description or content).

- [1] 3GPP TR 21.905: "Vocabulary for 3GPP Specifications".
- [2] 3GPP TS 38.508-1: "5GS; User Equipment (UE) conformance specification; Part 1: Common test environment".
<https://standards.iteh.ai/catalog/standards/sist/fb1d7335-dd0f-49e8-9ee7-0abc5f83ea90/etsi-138-508-1-2022-08>
- [3] 3GPP TS 38.523-1: "5GS; User Equipment (UE) conformance specification; Part 1: Protocol".
- [4] 3GPP TS 38.523-3: "5GS; User Equipment (UE) conformance specification; Part 3: Protocol Test Suites".
- [5] 3GPP TS 38.522: "NR; User Equipment (UE) conformance specification; Applicability of RF and RRM test cases".
- [6] 3GPP TS 36.509: "Evolved Universal Terrestrial Radio Access (E-UTRA) and Evolved Packet Core (EPC); Special conformance testing functions for User Equipment (UE)".
- [7] 3GPP TS 24.007: "Mobile radio interface signalling layer 3; General Aspects".
- [8] 3GPP TS 34.109: "Terminal logical test interface; Special conformance testing functions".
- [9] 3GPP TS 44.014: "Individual equipment type requirements and interworking; Special conformance testing functions".
- [10] 3GPP TS 36.331: "Evolved Universal Terrestrial Radio Access (EUTRA) Radio Resource Control (RRC) Protocol Specification".
- [11] 3GPP TS 38.331: "NR Radio Resource Control (RRC) protocol specification".
- [12] 3GPP TS 38.521-1: "NR; User Equipment (UE) conformance specification; Radio transmission and reception; Part 1: Range 1 Standalone".
- [13] 3GPP TS 38.521-2: "NR; User Equipment (UE) conformance specification; Radio transmission and reception; Part 2: Range 2 Standalone".

- [14] 3GPP TS 38.521-3: "NR; User Equipment (UE) conformance specification; Radio transmission and reception; Part 3: Range 1 and Range 2 Interworking operation with other radios".
- [15] 3GPP TS 38.521-4: "NR; User Equipment conformance specification; Radio transmission and reception; Part 4: Performance".
- [16] 3GPP TS 38.533: NR; "User Equipment (UE) conformance specification; Radio resource management".
- [17] 3GPP TS 24.301: "Non-Access-Stratum (NAS) protocol for Evolved Packet System (EPS); Stage 3".
- [18] 3GPP TS 36.323: "Evolved Universal Terrestrial Radio Access (E-UTRA); Packet Data Convergence Protocol (PDCP) specification".
- [19] 3GPP TS 38.323: "NR; Packet Data Convergence Protocol (PDCP) specification".
- [20] 3GPP TS 38.306: "NR; User Equipment (UE) radio access capabilities".
- [21] 3GPP TS 24.501: "Non-Access-Stratum (NAS) protocol for 5G System (5GS); Stage 3".
- [22] 3GPP TS 38.215: "NR; Physical Layer Measurements".

3 Definitions, symbols and abbreviations

3.1 Definitions

For the purposes of the present document, the terms and definitions given in 3GPP TR 21.905 [1] and the following apply. A term defined in the present document takes precedence over the definition of the same term, if any, in 3GPP TR 21.905 [1].

Frequency Range 2 (FR2): The frequency ranges in which NR can operate being in the range of 24250 MHz - 52600 MHz.

Logical Test Interface: interface which provides the logical service to interwork and to communicate between UE and System Simulator during the test of a UE

SS (System Simulator): test system (or equipment) that drives the test process with UE, like 5G System simulator

TMC (Test Mode Control): UE protocol entity used by the SS to control the UE specific testing functions

NOTE: In other Special conformance testing functions for User Equipment (UE) 3GPP specifications e.g. 36.509 [6], the term Test Control (TC) is used for describing the same UE entity. The different names do not preclude the implementation of a single entity to handle all the functionality in a UE supporting different 3GPP technologies.

UE (User Equipment): user equipment as defined in [1] that is under test

3.2 Symbols

No specific symbols apply for the purposes of the present document.

3.3 Abbreviations

For the purposes of the present document, the abbreviations given in 3GPP TR 21.905 [1] and the following apply. An abbreviation defined in the present document takes precedence over the definition of the same abbreviation, if any, in 3GPP TR 21.905 [1].

EMMI	Electrical Man Machine Interface
FFS	For further Study
FR2	Frequency Range 2
LB	Loop Back
MTC	Main Test Component
NSSAI	Network Slice Selection Assistance Information
SS	System Simulator
TMC	Test Mode Control

4 UE special conformance test functions overview

4.1 Requirements for UE support of test functions

The UE special conformance test functions are required for the support of 5GS conformance testing. They form a part of the core requirements and thus have a direct impact on the design of the UE. The use of the word "mandatory" in the present specification shall be understood as a particular requirement being mandatory for performing UE conformance testing.

NOTE: While the importance of conformance testing should not be underestimated, and hence is highly recommended, the implementation of facilitation of it is left to the Device implementation.

<https://standards.iteh.ai/catalog/standards/sist/fb1d7335-dd0f-49e8-9ee7-0abc5f83ea90/etsi-ts-138-509-v15-13-0-2022-08>

4.2 UE special conformance test functions concept

The present specification defines the UE special conformance test functions including any relevant procedure and the Test Mode Control (TMC) message contents used for information exchange.

The conformance test methods applied in RF/RRM Conformance Test Specification TS 38.521-1 [12], TS 38.521-2 [13], TS 38.521-3 [14], TS 38.521-4 [15] and TS 38.533 [16], and, the conformance test models used in Protocol Conformance Test Specifications TS 38.523-1 [3] and TS 38.523-3 [4], as well as, common test environment definition and Generic procedures specified in TS 38.508-1 [2] utilise the UE special conformance test functions. Default TMC messages and information element contents utilised in all before mentioned test specifications are specified in TS 38.508-1 [2].

The UE special conformance test functions vary depending on the conformance testing functionality they are designed to support. The following broader groups of UE special conformance test functions can be identified:

- **Test Loop Functions:** Functions which require a loop to be established between the UE and the System Simulator (SS) to allow e.g. DL data packets sent by the SS to be looped back UL by the UE
- **General Test Functions:** Commands send by the SS e.g. to trigger a certain UE behaviour which may be a behaviour determined by 3GPP core spec requirements or such needed to facilitate conformance testing and not being part of any 3GPP core spec requirements, or, to provide to the UE information needed for the conformance testing.

NOTE 1: An example for behaviour needed to facilitate conformance testing and not representing behaviour determined by 3GPP core spec requirements is counting and reporting the number of received data packets thereby providing means to the SS to verify 3GPP core spec requirements.

The utilisation of any UE special conformance test functions shall be considered as putting the UE in a test mode. The duration of the test mode depends on the UE special conformance test function and in most of the cases will be delimited by an activation and a deactivation command. However, in the case of general test functions used e.g. only to provide information relevant for the conformance testing the test mode can be considered as entered as soon as the information is received and exited as soon as the information has been acted upon.

As a common rule the UE special conformance test functions provide access to isolated functions of the UE via the radio interface without introducing new physical interfaces just for the reason of conformance testing. However, in certain cases the usage of AT Commands may be required which will require an external interface e.g. EMMI.

NOTE 2: It should be emphasised that the UE test functions only describe the functional behaviour of the UE with respect to its external interfaces; physical implementation of the UE test function is completely left open to the manufacturer.

Depending on the conformance testing functionality they are designed to support, the UE special conformance test functions may comprise:

- A single DL message (e.g. a test function intended to provide to the UE information needed for the conformance testing)
- A Request/Acknowledgement type of 2 messages exchange, an DL message followed by a UL message, (e.g. a test function intended to request the UE to execute an action which requires acknowledgment that request was received and acted upon)

Furthermore, depending on the conformance test scenarios

- An UE special conformance test function can be used in isolation.

NOTE 3: An example for this is the provision to the UE of location information which can then be used by the UE throughout its "normal" i.e. not test mode functions dependant behaviour.

- Two, or more, UE special conformance test functions may need to be executed in a particular sequence before the target UE behaviour can be assumed.

NOTE 4: An example for this are the Activate UE test mode and Close UE test loop functions. The former needs to be executed first, at a particular moment of time, in order a specific type of test bearer terminated in a particular UE protocol layer to be established. Followed by the latter, executed at different point of time, which will instruct the UE to start looping back the received packets.

- Two, or more, UE special conformance test functions may be executed simultaneously with no particular relation one to another allowing for different test mode functionality to take place at the same time.

NOTE 5: An example for this are the UE Beamlock test function and the test functions needed for test loop mode operation (see NOTE 4). The former may need to be active throughout the entire tests with the latter being active in parts of the test as appropriate. Both being active independently.

For the specification of UE special conformance test functions the present specification may refer to other specifications. In the case when text on the same matter exists in the present specification and in the referred specification, the text in the present specification takes precedence.

5 UE special conformance test functions operation

5.1 General

For consistency with legacy terminology, the present specification uses the terms 'Activate UE test mode' and 'Deactivate UE test mode' for denoting the activation and the deactivation of 5GS test mode bearers procedures respectively. Consequently, 'Activate UE test mode' should not be understood as setting the UE in test mode in general rather, as setting the UE in a mode (i.e. establishing a special type of test bearers) which other special UE conformance testing functions require for proper operation. As this has been mentioned elsewhere in the present specification, not all special UE conformance testing functions require such a setting.

Similarly, the present specification may use the term "UE test loop mode X operation", where X is a chosen letter, for denoting operation which does not represent true looping back of data being received rather, it represents what can be called as a "pseudo loop" i.e. providing back information about the received data e.g. the number of the received packets.

5.2 Activation and deactivation of 5GS test mode bearers (UE test mode procedures)

5.2.1 General

The SS performs, where applicable, activation and deactivation of the conformance test functions in the UE by sending Security Protected NAS Layer 3 messages.

The UE test mode procedures are intended for setting the UE into a test mode where the SS can set up test bearers terminated at a particular point in the 5GS protocol stack as specified in the functional block diagram of each UE test loop mode of operation. The following test bearers are defined in the present specification:

- data radio bearers (UE test loop mode A),
- EPS bearers or 5GS QoS flows (UE test loop mode B).

5.2.2 Activate UE test mode

Same as TS 36.509 [6], subclause 5.3.2 with the following exceptions:

- where E-UTRA is mentioned the same applies for NR;

the NB-IoT mode is out of the scope of the present specification;

where different UE test loop modes are mentioned only those applicable to 5GS should be taken into account (see subclause 5.3.4 for the applicable 5GS UE test loop modes).

5.2.3 Deactivate UE test mode

Same as TS 36.509 [6], subclause 5.3.3 with the following exceptions

- where E-UTRA is mentioned the same applies for NR;
- the NB-IoT mode is out of the scope of the present specification;
- where different UE test loop modes are mentioned only those applicable to 5GS should be taken into account (see subclause 5.3.4 for the applicable 5GS UE test loop modes).

Apart from sending the appropriate deactivation command to the UE the functions shall be deactivated by:

switching off the UE; or

by removing the USIM.

5.3 Test loop functions

5.3.1 General

Before a loop functionality can be exercised, the test loop needs to be closed; this is to be understood as the UE being instructed to start looping back received data packets. When looping back received data packets is no longer required the loop should be re-opened; opening of a loop does not change the type of bearer being established by the UE test mode activation function (subclause 5.2.2).

To limit the number of special test functions, the concept of closing and opening a loop is also used as instruction to the UE to initiate/terminate other actions. An example of this is counting the received packets and reporting the number of

received packets back to the SS; in the context of this utilisation closing a loop is to be understood as the UE being instructed to start counting the packets, whereas opening a loop should be understood as stop counting the packets. Other utilisation of the closing/opening a "test loop" test functionality can be specified if appropriate.

The UE test loop functions for 5GS are intended for:

- NR receiver and transmitter testing to disable application data transfer in downlink and uplink during SS UE measurements.
- NR layer 2 (MAC, RLC, PDCP, SDAP) and data radio bearer testing to generate data transfer in downlink and uplink.
- 5GC and NR layer 3 testing to verify data transfer continuation over RRC and 5GC procedures.
- 5GC NAS user-plane testing to verify uplink QoS flow descriptions handling.

5.3.2 Close UE test loop

Same as TS 36.509 [6], subclause 5.4.2 with the following exceptions:

- where E-UTRA is mentioned the same applies for NR;
- the NB-IoT mode is out of the scope of the present specification
- where different UE test loop modes are mentioned only those applicable to 5GS should be taken into account (see subclause 5.3.4 for the applicable 5GS UE test loop modes).
- where EPS bearers are mentioned the same applies for 5GS QoS flows; and
- UE supported minimum buffer size for MR-DC and NR shall match the required total layer 2 buffer size as specified in TS 38.306 [20], clause 4.1.4.

5.3.3 Open UE test loop

Same as TS 36.509 [6], subclause 5.4.5 with the exceptions:

- where E-UTRA is mentioned the same applies for NR;
- the NB-IoT mode is out of the scope of the present specification;
- where different UE test loop modes are mentioned only those applicable to 5GS should be taken into account (see subclause 5.3.4 for the applicable 5GS UE test loop modes).

5.3.4 UE functionality when test loop is closed

5.3.4.1 UE test loop mode A operation

UE test loop mode A provides loopback of PDCP SDUs for bi-directional data radio bearers while UE is operating in NR. The downlink PDCP SDUs received by the UE on each bi-directional data radio bearer are returned on the same radio bearer regardless of the PDCP SDU contents and of the QoS flow descriptions of the associated QoS Flow as specified in TS 24.501 [21].

Figures 5.3.4.1-1 and 5.3.4.1-2 show functional block diagrams of UE test loop function for the TMC entity and UE test loop mode A for the case when EN-DC or NGEN-DC with a MCG bearer and a SCG bearer is configured and for the case EN-DC or NGEN-DC with a MCG and a split bearer is configured.

Figures 5.3.4.1-3 shows functional block diagrams of UE test loop function for the TMC entity and UE test loop mode A for the case when standalone NR is configured.

Figures 5.3.4.1-4 and 5.3.4.1-5 show functional block diagrams of UE test loop function for the TMC entity and UE test loop mode A for the case when NE-DC with a MCG bearer and a SCG bearer is configured and for the case NE-DC with a MCG and a split bearer is configured.

NOTE 1: The number and the order of RB LB Entities in the functional block diagrams are provided for illustration only. No specific order or numbering is precluded.

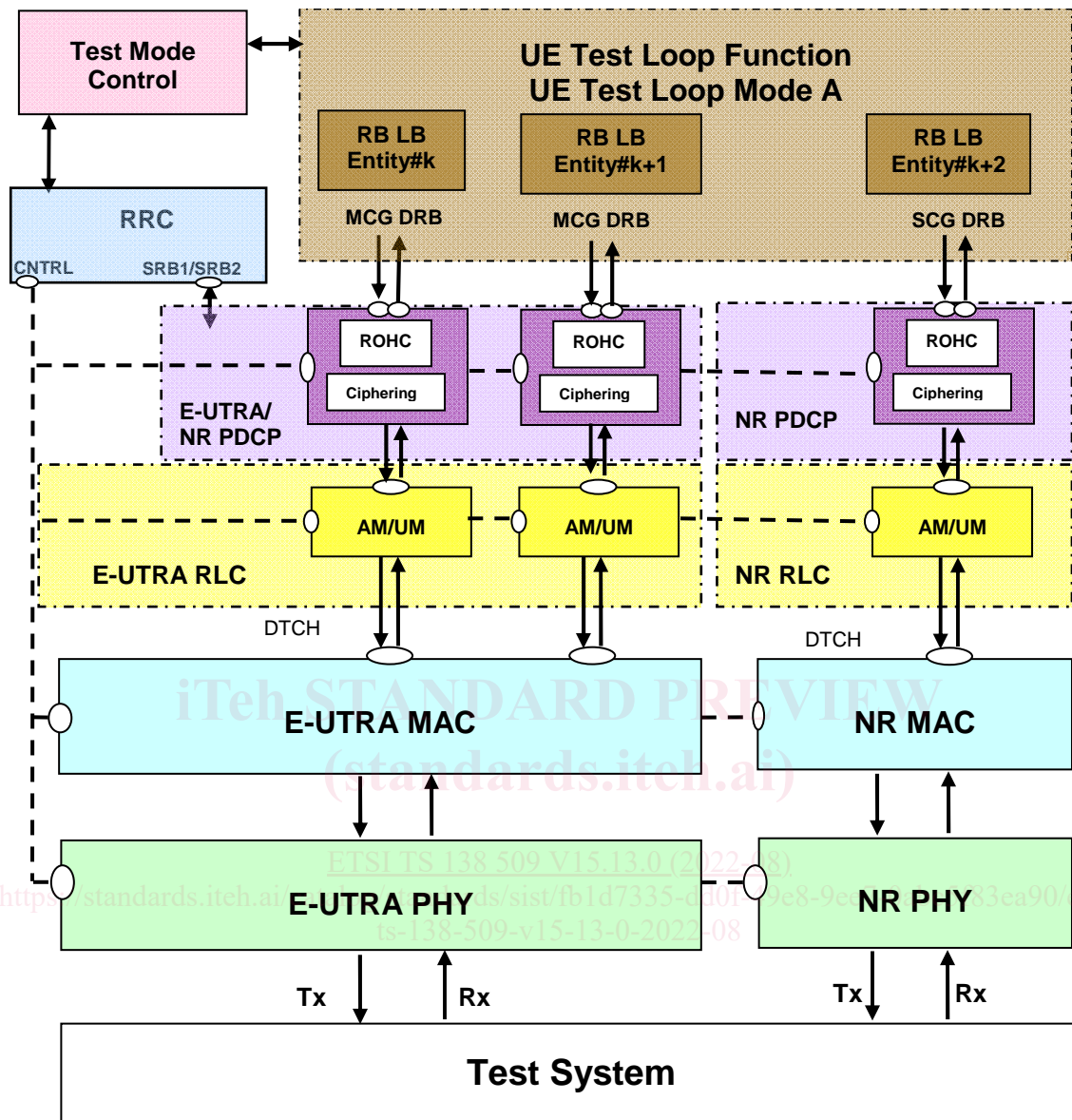

Figure 5.3.4.1-1: Model for Test Mode Control and UE Test Loop Mode A on UE side when EN-DC or NGEN-DC with MCG bearer and SCG bearer is configured