



Standard Specification for 3.25-in. Outside Diameter Poly(Vinyl Chloride) (PVC) Plastic Drain, Waste, and Vent Pipe and Fittings¹

This standard is issued under the fixed designation D2949; the number immediately following the designation indicates the year of original adoption or, in the case of revision, the year of last revision. A number in parentheses indicates the year of last reapproval. A superscript epsilon (ϵ) indicates an editorial change since the last revision or reapproval.

This standard has been approved for use by agencies of the Department of Defense.

1. Scope

1.1 This specification covers requirements and test methods for materials, dimensions and tolerances, deflection load, crush resistance, hydrostatic-burst resistance, flattening resistance, impact resistance, and solvent cement. A form of marking is also included. Plastic which does not meet the material requirements specified in Section 5 is excluded.

NOTE 1—This specification was formerly issued under the title, 3-in. Thin Wall Poly(Vinyl Chloride) (PVC) Plastic Drain, Waste, and Vent Pipe and Fittings.

NOTE 2—Techniques for making solvent-cement joints are given in Practice D2855.

1.2 The text of this specification references notes, footnotes, and appendixes which provide explanatory material. These notes and footnotes (excluding those in tables and figures) shall not be considered as requirements of the specification.

1.3 The values stated in inch-pound units are to be regarded as standard. The values given in parentheses are mathematical conversions to SI units that are provided for information only and are not considered standard.

1.4 The following precautionary caveat pertains only to the test methods portion, Section 7, of this specification: *This standard does not purport to address all of the safety concerns, if any, associated with its use. It is the responsibility of the user of this standard to establish appropriate safety and health practices and determine the applicability of regulatory limitations prior to use.*

2. Referenced Documents

2.1 ASTM Standards:²

D618 Practice for Conditioning Plastics for Testing

¹ This specification is under the jurisdiction of ASTM Committee F17 on Plastic Piping Systems and is the direct responsibility of Subcommittee F17.63 on DWV. Current edition approved Nov. 1, 2008. Published February 2009. Originally approved in 1971. Last previous edition approved in 2001 as D2949 – 01a^{ε1}. DOI: 10.1520/D2949-01AR08.

² For referenced ASTM standards, visit the ASTM website, www.astm.org, or contact ASTM Customer Service at service@astm.org. For *Annual Book of ASTM Standards* volume information, refer to the standard's Document Summary page on the ASTM website.

- D1599 Test Method for Resistance to Short-Time Hydraulic Pressure of Plastic Pipe, Tubing, and Fittings
- D1600 Terminology for Abbreviated Terms Relating to Plastics
- D1784 Specification for Rigid Poly(Vinyl Chloride) (PVC) Compounds and Chlorinated Poly(Vinyl Chloride) (CPVC) Compounds
- D2122 Test Method for Determining Dimensions of Thermoplastic Pipe and Fittings
- D2152 Test Method for Adequacy of Fusion of Extruded Poly(Vinyl Chloride) (PVC) Pipe and Molded Fittings by Acetone Immersion
- D2412 Test Method for Determination of External Loading Characteristics of Plastic Pipe by Parallel-Plate Loading
- D2444 Test Method for Determination of the Impact Resistance of Thermoplastic Pipe and Fittings by Means of a Tup (Falling Weight)
- D2564 Specification for Solvent Cements for Poly(Vinyl Chloride) (PVC) Plastic Piping Systems
- D2855 Practice for Making Solvent-Cemented Joints with Poly(Vinyl Chloride) (PVC) Pipe and Fittings
- D3311 Specification for Drain, Waste, and Vent (DWV) Plastic Fittings Patterns
- F402 Practice for Safe Handling of Solvent Cements, Primers, and Cleaners Used for Joining Thermoplastic Pipe and Fittings
- F412 Terminology Relating to Plastic Piping Systems
- F1498 Specification for Taper Pipe Threads 60° for Thermoplastic Pipe and Fittings

3. Terminology

3.1 *Definitions*—Definitions are in accordance with Terminology F412, and abbreviations are in accordance with Terminology D1600, unless otherwise specified.

4. Significance and Use

4.1 The requirements of this specification are intended to provide pipe and fittings suitable for drainage of sewage and certain other liquid wastes where toughness, resistance to

deterioration from water and chemicals, flattening and aging resistance, and strong tight joints are required.

4.2 When joining 3.25-in. outside diameter PVC DWV piping to 3-in. Schedule 40 PVC DWV piping, it is necessary to use either reducer bushings or increasers, as shown in the tables at the end of the text, due to the differences in pipe outside diameters.

NOTE 3—Industrial waste disposal lines should be installed only with the specific approval of the cognizant building code authority since chemicals not commonly found in drains and sewers, and temperatures in excess of 160°F (70°C), may be encountered.

5. Materials

5.1 *Basic Materials*—Pipe and fittings shall be made from virgin poly (vinyl chloride) compounds meeting the requirements of Class 12454, as defined and described in Specification D1784.

5.2 *Rework Material*—The manufacturer shall use only his own clean pipe or fitting rework material and the pipe or fitting produced shall meet all the requirements of this specification.

5.3 *Solvent Cement*—The solvent cement shall meet the requirements of Specification D2564.

6. Requirements

6.1 *General*—The pipe and fittings shall be homogeneous throughout and free of visible cracks, holes, foreign inclusions, or other injurious defects. The pipe shall be as uniform as commercially practicable in color, opacity, density, and other physical properties.

6.1.1 The requirements in this section are intended only for use as quality control tests, not as simulated service tests.

6.2 *Dimensions and Tolerances*—All dimensions shall be measured in accordance with Test Method D2122. All tolerances shall meet the requirements of Tables 1-11 unless otherwise specified.

6.2.1 Pipe:

6.2.1.1 *Pipe Dimensions*—The outside diameters and wall thicknesses of the pipe shall meet the requirements of Table 1.

6.2.1.2 *Pipe Length*—The pipe shall be in either 10 or 20-ft or 3 or 6-m lengths, unless otherwise specified with allowable tolerance of +1/2 in., 0 in. or +13 mm, –0 mm.

6.2.2 Fittings:

6.2.2.1 *Fittings-Socket Dimensions*—The socket dimensions of fittings shall meet the requirements given in Table 2.

6.2.2.2 *Fittings Laying Length Dimensions*—The laying length dimensions of fittings, shall conform to the requirements given in Table 3 through Tables 11.

6.2.2.3 *Transition Adapters*—The dimensions of adapters for connecting plastic pipe to cast iron hubs shall conform to the dimensions given in Table 4.

6.2.2.4 *Fittings Dimensions*—The dimensions of fittings covered by this specification shall meet the requirements given in Table 3 through Table 11.

NOTE 4—Additional fittings in IPS dimensions are included in Specification D3311.

6.3 Deflection Load and Crush Resistance:

6.3.1 *Pipe*—The pipe shall support a minimum load of 600 lbf/linear ft (810 N/m) at 15 % deflection of the original diameter (deflection load), and shall deflect 60 % of the original diameter (crush resistance) without cracking, rupture, or other visible evidence of failure when tested in accordance with 7.4. The minimum pipe stiffness at 5 % deflection shall be 115 lbf/in.·in. (800 kPa).

6.3.2 *Fittings*—Individual fittings unassembled shall withstand a minimum load of 1000 lbf/ft (1350 N/m) of centerline length without cracking or other visible evidence of failure when tested in accordance with 7.4. This requirement does not apply to inline fittings.

6.4 *Minimum Hydrostatic Burst Pressure*—When tested at 73°F (23°C) in accordance with 7.5, the minimum burst pressure of pipe shall be 500 psi (3.45 MPa) and the minimum burst pressure of fittings shall be 200 psi (1.38 MPa).

NOTE 5—The minimum burst pressure for fittings are lower than that for pipe because the geometry is such, particularly area and radii, that the stresses produced in the wall of the fitting are higher than those produced in pipe tested at the same internal pressures. This requirement is intended only for the purpose of quality control to ensure that the pipe and fittings have no weak areas, particularly at flow and weld lines.

6.5 *Flattening Resistance*—The average decrease in inside diameters of pipe and fittings shall not exceed 10 % when tested in accordance with 7.6 (Note 3).

6.6 *Impact Resistance*—The minimum impact resistance, when tested at the time of manufacture, shall be 50 ft·lbf (6.91 J) at 73°F (23°C) for pipe and 20 ft·lbf (2.77 J) at 73°F for fittings. Test in accordance with Test Method D2444 using Tup C and Holder A for pipe and Tup A and Holder B for fittings. Use a 12-lb (5-kg) tup for testing pipe and fittings. Test couplings cemented to short pieces of pipe and allowed to dry for 24 h.

6.6.1 Test 10 specimens. When 9 or 10 specimens pass, accept the lot. When 2 or more specimens fail, test 10 additional specimens. When 17 of 20 specimens tested pass, accept the lot. When 4 or more of 20 specimens fail, test 20 additional specimens. When 32 of 40 specimens pass, accept the lot. When 9 or more of 40 specimens fail, the lot does not meet the requirements of this specification.

6.6.2 Failure of the test specimen shall be shattering or any crack or break extending entirely through the pipe wall and visible to the unaided eye.

TABLE 1 Dimensions and Tolerances for Outside Diameters and Thicknesses of PVC 3.25-in. Outside Diameter Plastic Drain, Waste, and Vent Pipe, in. (mm)

Nominal Pipe Size, in.	Outside Diameter			Wall Thickness ⁴	
	Average	Tolerance on Average	Out-of-Roundness (maximum minus minimum)	Min	Tolerance
3.25	3.250 (82.56)	±0.008 (±0.20)	0.030 (0.76)	0.125 (3.18)	+0.020 (+0.50)

⁴ The minimum is the lowest wall thickness of the pipe at any cross section. The maximum permitted wall thickness, at any cross section, is the minimum wall thickness plus the stated tolerance.

TABLE 2 Dimensions and Tolerances for Fitting Sockets for 3.25-in. Outside Diameter PVC Plastic Drain, Waste, and Vent Pipe Fittings, in. (mm)

NOTE 1—Spigot ends shall conform to the outside diameters and tolerances for pipe of the same size

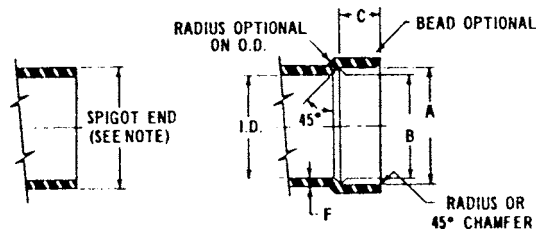

Nominal Pipe Size, in.	A Socket Entrance Diameter		B Socket Bottom Diameter		C Spigot and Socket Depth	D Wall Thickness
	avg ^A	Tm ^B	avg ^C	Tm ^B	min	min ^{D,E}
3.25	3.265 (82.94)	±0.008 (±0.20)	3.245 (82.42)	±0.008 (±0.20)	1½ (38)	0.140 (3.56)

^A The tolerances on this average are +0.010 to -0.005 in. (+0.25 to -0.13 mm).

^B Tm = permissible deviation of diameter from measured average, often called out-of-roundness.

^C Tolerance on average +0.005 in., -0.010 in. (+0.13 mm, -0.25 mm).

^D Minimum wall thickness in the socket is 0.125 in.

^E The wall thickness is a minimum value except that a ±10 % variation resulting from core shift is allowable. In such a case, the average of the two opposite wall thicknesses shall equal or exceed the value shown in the table.

TABLE 3 3.25-in. Outside Diameter Bends, in. (mm)

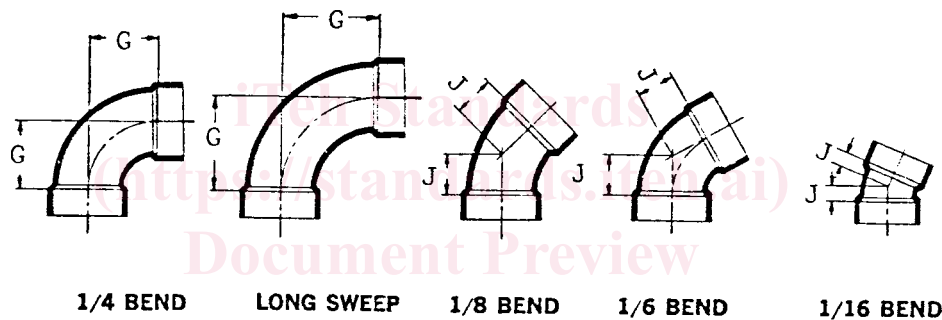

Nominal Pipe Size, in.	¼ Bend G, min	Long-Sweep ¼ Bend G, min	⅛ Bend J, min	⅙ Bend J, min	⅑ Bend J, min
3.25	2⅞ (73)	4 (101.6)	1 (25.4)	1¼ (31.8)	⅝ (15.88)

TABLE 4 3.25-in. Outside Diameter Reducing Spigots, in. (mm)

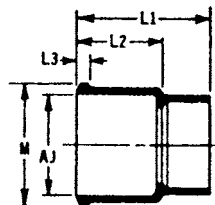

PLASTIC SPIGOT, Reducing Adapts Cast Iron Hub to Plastic Pipe

Nominal Pipe Size, in.	L ₂ , min	L ₁ , min	L ₃ , min	M		AJ, Nominal
				max	min	
3.25 by 4-in. Cast Iron	3⅞ (98.4)	5⅝ (142.9)	⅝ (9.5)	4⅞ (115.9)	4½ (114.3)	3⅞ (98.4)

TABLE 5 3.25-in. Outside Diameter Reducing Sanitary Tee and 45° Wyes, in. (mm)

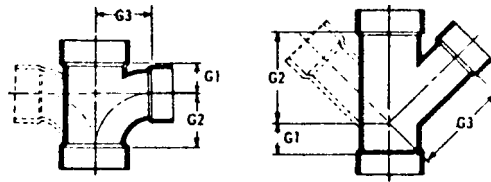

SANITARY TEE, Reducing
Single & Double

45° WYE, Reducing
Single & Double

Nominal Pipe Size, in.	Sanitary Tee Reducing			45° Wye Reducing Single and Double		
	G ₁ , min	G ₂ , min	G ₃ , min	G ₁ , min	G ₂ , min	G ₃ , min
3.25 by 3.25 by 1½-in. IPS	15/16 (23.8)	1¾ (44.5)	2¾ (55.6)	5/8 (9.5)	3¼ (82.5)	3 ¹⁷ / ₃₂ (89.7)
3.25 by 3.25 by 2-in. IPS	1¾ (34.9)	2 (50.8)	2¼ (57.2)	5/8 (9.5)	3¼ (82.5)	3 ¹¹ / ₁₆ (93.6)

TABLE 6 3.25-in. Outside Diameter Bushings in. (mm)

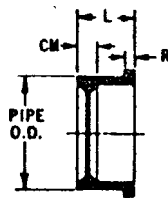

BUSHING
Style 1

Nominal Pipe Size, in.	Style 1		
	L, min	CM, min	R, min
3.25 by 1½-in. IPS	1 ⁷ / ₈ (47.6)	1 ¹ / ₈ (28.6)	3/8 (9.5)
3.25 by 2-in. IPS	1 ⁷ / ₈ (47.6)	1 (25.4)	3/8 (9.5)
3.25 by 3-in. IPS	1¾ (44.5)	¼ (6.4)	0 (0)

7.3.1 For referee purposes, conduct tests in the standard laboratory atmosphere of 73.4 ± 3.6°F (23 ± 2°C) and 50 ± 5 % relative humidity.

7.3.2 For routine quality control testing, conduct tests at the temperature and humidity of the manufacturers testing area.

7.4 Deflection Load and Crush Resistance—Measure the deflection load and crush resistance of pipe and fittings in accordance with Test Method D2412. In the test for pipe note the load when the initial inside diameter is reduced by 5 % (pipe stiffness), by 15 % (deflection load), and continue the test until the diameter is reduced by 60 % of its original value (crush resistance). The rate of head approach shall be 0.20 to 0.25 in./min (5.1 to 6.4 mm/min). Each specimen shall meet the requirements of 6.3.1.

7.4.1 Fitting Test Specimens—Test three complete fittings. Shim fittings to give full centerline contact with platens. Fittings having nonuniform diameters such as reducers shall be considered acceptable when the wall thickness at all points is equal to or greater than the wall thickness of pipe of the same material and diameter that meets the crush resistance requirements. Each specimen shall meet the requirements of 6.3.2.

7.4.2 Procedure—Terminate the test when the inside diameter of pipe test specimens is reduced to 40 % of its original value or the pipe cracks or shows other visible evidence of failure. Terminate the test on fittings when the load reaches 1000 lbf/ft (1350 N/m) of centerline length. Observe the load and deflection at the first evidence of cracking, if any. Record location and type of failure.

7.4.3 Calculation—For pipe, divide the load in pounds-force or newtons at 15 % deflection (deflection load) and also at failure (crush resistance), if such occurred, by the length of the pipe test specimen in feet or metres to obtain the deflection load and crush resistance, respectively, in pounds per linear foot, or newtons per metre. For pipe stiffness, divide the load in pounds-force or newtons at 5 % deflection by the specimen length in inches or metres and then divide by the deflection in inches or metres. Calculate the values for each specimen separately. Examine the test results for each specimen for conformance to the requirements of 6.3.1 and 6.3.2.

6.7 Threads—For all fittings having taper pipe threads, threads shall conform to Specification F1498 and be gaged in accordance with 7.7.

6.8 Extrusion Quality—The pipe shall not flake or disintegrate when tested in accordance with Test Method D2152.

7. Test Methods

7.1 Sampling—Take a random sample from each lot or shipment of the pipe and fittings sufficient to determine conformance with this specification. About 40 ft (12 m) of pipe are required to make the tests prescribed. The number of fittings required varies depending on the size and type of fitting.

7.2 Conditioning—

7.2.1 For referee testing at 73°F, condition the specimens prior to test at 73.4 ± 3.6°F (23 ± 2°C) and 50 ± 5 % relative humidity in accordance with Practice D618, Procedure A.

7.2.2 For routine quality control testing at 73°F, condition the specimens at the temperature and humidity of the manufacturers testing facility for not less than 1 h or until the specimens are at the room temperature.

7.3 Test Conditions—