



Designation: ~~D4772-97 (Reapproved 2008)~~^{ε1} Designation: D 4772 – 09

Standard Test Method for Surface Water Absorption of Terry Fabrics (Water Flow)¹

This standard is issued under the fixed designation D 4772; the number immediately following the designation indicates the year of original adoption or, in the case of revision, the year of last revision. A number in parentheses indicates the year of last reapproval. A superscript epsilon (ϵ) indicates an editorial change since the last revision or reapproval.

~~^{ε1}Note—Minor editorial corrections were made throughout in October 2008.~~

1. Scope

1.1 This test method determines the ability of a terry fabric to rapidly absorb and retain liquid water from surfaces such as human skin, dishes, and furniture.

1.2 This test method is not applicable to non-terry fabrics such as huck towels, waffle-weave towels, crash towels, flour-sack towels, and nonwoven wipes. The steep angle of the specimen on the apparatus may cause a large amount of water to runoff these non-pile fabrics, or the lightweight/open structure of these fabrics may allow a large amount of water to completely pass through the specimen; thus the test result may not be a valid measure of a non-terry fabric's ability to absorb water.

1.3 This test method is not applicable to decorative terry fabrics that will not be used to absorb water from surfaces.

1.4 This test method is written in SI units. The inch-pound units that are provided are not necessarily exact equivalents of the SI units. Either system of units may be used in this test method. In case of referee decisions the SI units will prevail.

1.5 *This standard does not purport to address all of the safety concerns, if any, associated with its use. It is the responsibility of the user of this standard to establish appropriate safety and health practices and determine the applicability of regulatory limitations prior to use.*

2. Referenced Documents

2.1 ASTM Standards:²

D 123 Terminology Relating to Textiles

D 1776 Practice for Conditioning and Testing Textiles

D 2904 Practice for Interlaboratory Testing of a Textile Test Method that Produces Normally Distributed Data

D 2906 Practice for Statements on Precision and Bias for Textiles

D 3136 Terminology Relating to Care Labeling for Apparel, Textile, Home Furnishing, and Leather Products

D 5433 Performance Specification for Towel Products for Institutional and Household Use

2.2 AATCC Standard:

Test Method 135 Dimensional Changes in Automatic Home Laundering of Woven and Knit Fabrics³ [/astm-d4772-09](http://astm-d4772-09)

3. Terminology

3.1 Definitions:

3.1.1 *absorption, n*—a process in which one material (the absorbent) takes in or absorbs another (the absorbate); as the absorption of moisture by fibers.

3.1.2 *pile, n*—*in pile fabric*, the raised loops or tufts (cut loops) that form all or part of the surface.

3.1.3 *surface water absorption, n*—*by a fabric*, the process of removing liquid water from a surface such as human skin, dishes, or furniture.

3.1.4 *terry fabric, n*—a material with a woven warp pile or a knitted pile, with uncut loops on a single side or uncut loops on both sides, and which is used for such products as toweling, beachwear, and bathrobes.

3.1.5 For definitions of other textile terms used in this test method, refer to Terminologies D 123 and D 3136.

4. Summary of Test Method

4.1 A terry fabric product with hems or with both hems and selvages (such as a bath towel), or a terry fabric without hems or

¹ This test method is under the jurisdiction of ASTM Committee D13 on Textiles and is the direct responsibility of Subcommittee D13.59 on Fabric Test Methods, General Current edition approved July 1, 2008. Published October 2008. Originally approved in 1988. Last previous edition approved in 2004 as D4772-88(2004). Current edition approved Jan. 15, 2009. Published February 2009. Originally approved in 1988. Last previous edition approved in 2008 as D 4772 – 97(2008) ^{ε1}.

² For referenced ASTM standards, visit the ASTM website, www.astm.org, or contact ASTM Customer Service at service@astm.org. For Annual Book of ASTM Standards volume information, refer to the standard's Document Summary page on the ASTM website

³ Available from American Association of Textile Chemists and Colorists (AATCC), P.O. Box 12215, Research Triangle Park, NC 27709, <http://www.aatcc.org>.

without both hems and selvages (such as a terry fabric cut from a roll) is prepared for testing by preconditioning and conditioning. Specimens are placed one at a time in an embroidery hoop and then the hoop/specimen assembly is placed at an angle on the base of the apparatus. After water flows down the surface of each specimen, the amount of water retained by each specimen is measured. Six specimens are tested, three on the face of the fabric and three on the back of the fabric. The six observations are averaged to determine the surface water absorption of the fabric.

5. Significance and Use

5.1 This test method may be used to test the surface water absorption of terry fabrics for bath towels, bath sheets, hand towels, kitchen towels, dishcloths, washcloths, beachwear, bathrobes, and the like. Different specifications may be needed for each of these fabrics because of different applications.⁴

5.2 It is recognized that surface water absorption is only one of the characteristics that the ultimate consumer may use in determining which terry fabric is acceptable. Consult Specification D 5433 for other characteristics that may be applicable to terry fabrics.

5.3 This test method is recommended for quality control testing of terry fabrics during manufacturing and product comparisons of different terry fabrics by manufacturers, retailers, and users.

5.4 This test method may be used for the acceptance testing of commercial shipments of terry fabrics, but caution is advised since interlaboratory precision is known to be poor. Comparative tests as directed in 5.4.1 may be advisable.

5.4.1 In case of a dispute arising from differences in reported test results when using this test method for acceptance testing of commercial shipments, the purchaser and the supplier should conduct comparative tests to determine if there is a statistical bias between their laboratories. Competent statistical assistance is recommended for the investigation of bias. As a minimum, the two parties should take a group of laboratory sampling units (such as towels) that are as homogeneous as possible and that are from a lot of material of the type in question. The laboratory sampling units should then be randomly assigned in equal numbers to each laboratory for testing. The average results from the two laboratories should be compared using appropriate statistical analysis for unpaired data and an acceptable probability level chosen by the two parties before the testing is begun. If a bias is found, either its cause must be found and corrected or the purchaser and supplier must agree to interpret future test results with consideration of the known bias.

6. Apparatus and Materials

6.1 *Water Flow Tester*—This tester is not commercially available, but it is not difficult or expensive to build. The tester shown in Figs. 1-3 can be made from the parts and the series of steps described in Annex A1; however, there are other acceptable ways to build the tester. Sections 6.1.1-6.1.4 indicate the critical factors which must be incorporated into the design of the tester.

6.1.1 The hoop/specimen assembly must be at 1.1 rad (60°) to the table top (see Fig. 1 and Fig. 3).

6.1.2 The 50-mL graduate mounted on the apparatus must be parallel to the table top (see Figs. 1 and 2). The pour spout on this graduate must be 3.0 ± 0.2 cm (1.18 ± 0.08 in.) down from where the adjustment screw bracket joints the outer hoop and 0.6 ± 0.4 cm (0.24 ± 0.16 in.) away from the hoop/specimen assembly (see Fig. 1 and Fig. 3).

6.1.3 The funnel, valve, fittings, tubing, and graduate mounted on the apparatus (see Fig. 2) must not restrict the flow of water. The time between the opening of the valve and the time the water has exited the graduate (except for a few drops) must be less than 8.0 s. (The tester shown in Figs. 2 and 3 has a mean of 5.7 s and a standard deviation of 0.5 s).

6.1.4 The hoop/specimen assembly must be mounted on the base in a manner to direct all water not absorbed by the specimen toward the pan (see Figs. 1-3). It is especially important that any water that passes completely through the specimen is directed toward the pan and is not allowed to be absorbed by the lower portion of the specimen, or the edge of the laboratory sampling unit, or held where the hoop contacts the base.

6.2 *Embroidery Hoop*, 15.3-cm (6-in.) outer diameter of inner hoop. If the hoop is made of wood, it must have a water-resistant finish (such as a marine varnish).

6.3 *Graduate, Polymethylpentene (PMP)* 50 mL.

6.4 *Distilled or Deionized Water*, at $21 \pm 1^\circ\text{C}$ ($70 \pm 2^\circ\text{F}$).

6.5 *Laboratory Sampling Unit Conditioning Equipment*, facilities such as a multiple shelf/rod conditioning rack (for example see Practice D 1776) or a clothesline and clothespins. For more information see 9.2.

6.6 *Tumble Dryer*, equivalent to the one described in AATCC Test Method 135.

6.7 *Washing Machine*, equivalent to the one described in AATCC Test Method 135.

6.8 *Detergent*, heavy duty granule, equivalent to The 1993 AATCC Standard Reference Detergent described in AATCC Test Method 135 or any detergent agreed upon by the purchaser and the supplier that does not include fabric softener or bleach.

7. Sampling

7.1 *Lot Sample*—As a lot sample for acceptance testing, take at random the number of shipping cartons or the number of rolls

⁴ The relationship between water and textiles is complex. For information on the different forms of interaction between water and textiles see: Zeronian, S. H. "Analysis of the Interaction Between Water and Textiles," pages 117-128 in *Analytical Methods for a Textile Laboratory*, American Association of Textile Chemists and Colorists, third edition, 1984, edited by J. W. Weaver.

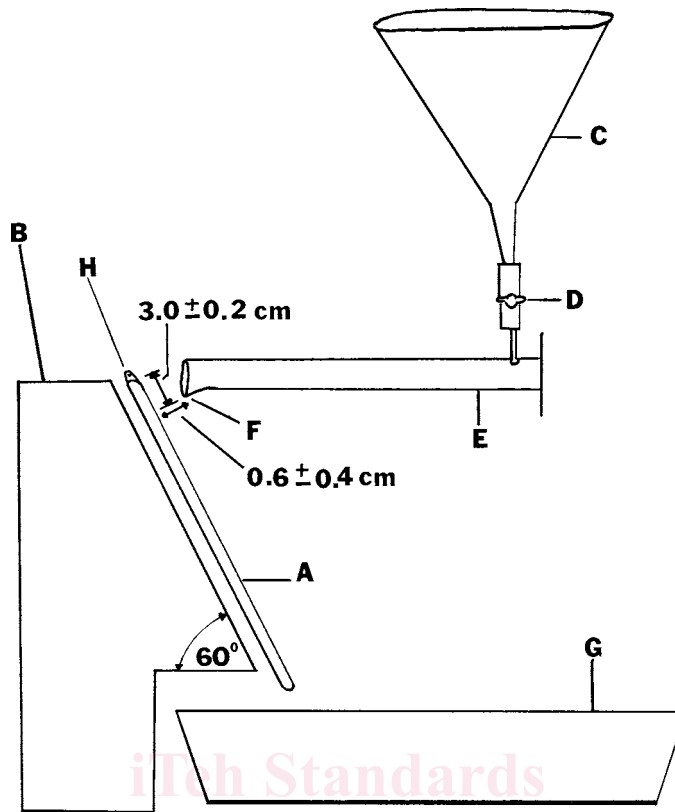

- A = Hoop,
- B = Base,
- C = Funnel,
- D = Valve,
- E = Graduate,
- F = Pour Spout,
- G = Pan, and
- H = Adjustment Screw.

FIG. 1 Schematic Diagram of a Typical Water Flow Tester

of fabric directed in an applicable material specification or other agreement between the purchaser and the supplier. Consider shipping cartons or rolls of fabric to be the primary sampling units, see Note 1.

NOTE 1—Any agreement between the purchaser and supplier must take into account the variability between rolls, bolts, or pieces of fabric and between specimens from a swatch of fabric from a roll, bolt, or piece, or between cartons of garments and between garments within a carton, to provide a sampling plan with a meaningful producer’s risk, consumer’s risk, acceptable quality level, and limiting quality level.

7.2 *Laboratory Sample*—As a laboratory sample for acceptance testing, take the number of laboratory sampling units specified in the agreement between the purchaser and the supplier. Take the laboratory sampling units as follows:

7.2.1 *Recommended Laboratory Sampling Unit*—Because this is a nondestructive test method, the recommended laboratory sampling unit is a terry fabric product with hems or with both hems and selvages (such as a bath towel). The fabric should be dyed and finished as the consumer would purchase it. A fabric approximately 112 (lengthwise direction) by 56 cm (44 by 22 in.) or larger is easier to test than a small fabric as all six observations can be made on one fabric, but the procedure allows for testing a small fabric such as a hand towel (see Note 2).

NOTE 2—A 20.0 by 20.0-cm (7.87 by 7.87-in.) fabric is the smallest laboratory sampling unit that can be tested on the apparatus. Six of these small laboratory sampling units will be needed to provide the six observations. In choosing the size of the laboratory sampling unit, keep in mind that terry fabric has a high degree of shrinkage during washing and drying.

7.2.2 *Alternate Laboratory Sampling Unit*—As an alternative to the procedure described in 7.2.1, a terry fabric without hems or without both hems and selvages can be used (such as a terry fabric cut from a roll). The fabric should be dyed and finished as the consumer would purchase it. A fabric approximately 112 (lengthwise direction) by 56 cm (44 by 22 in.) or larger is easier to test than a small fabric as all six observations can be made on one fabric, but the procedure allows for testing a small fabric (see Note 2).

7.3 *Specimens*—After the laboratory sampling unit(s) has been prepared as directed in Section 8 and conditioned as directed in Section 9, take six specimens (the area inside the hoop) by locating the hoop on the laboratory sampling unit(s) as follows:

7.3.1 For a laboratory sampling unit(s) that is approximately 112 (lengthwise direction) by 56 cm (44 by 22 in.) or larger, locate the hoop as shown in Fig. 4.

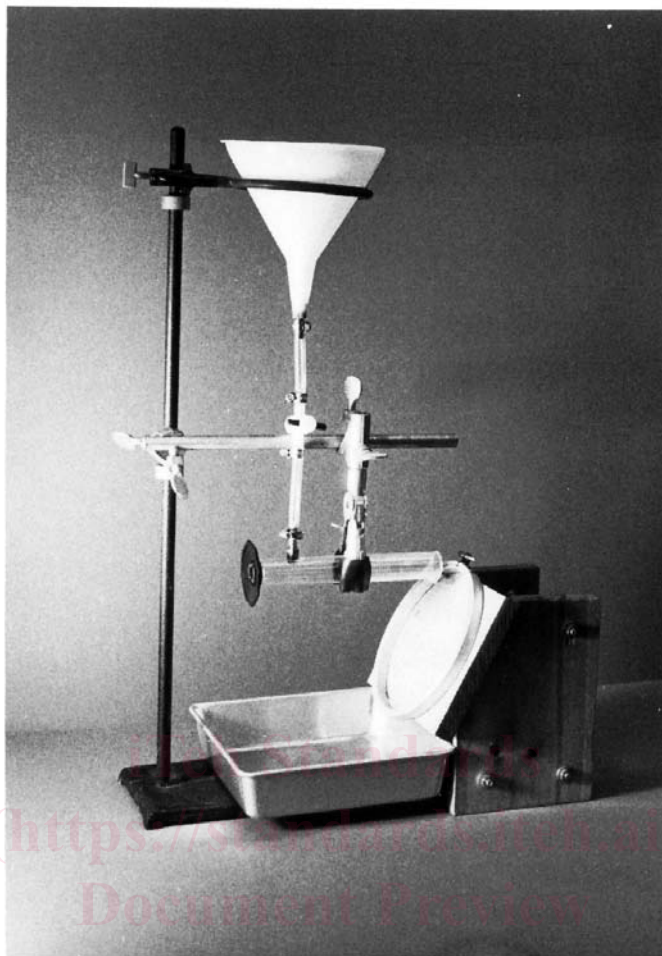

FIG. 2 A Typical Water Flow Tester

7.3.2 For a laboratory sampling unit(s) that is not large enough to locate the hoop so that all six specimens are on one laboratory sampling unit, alternate the hoop from face to back using as many laboratory sampling units as needed to obtain the six specimens.

8. Preparation of the Laboratory Sampling Unit

8.1 *Recommended Preparation of the Laboratory Sampling Unit*—The recommended preparation of the laboratory sampling unit uses a dryer to precondition the laboratory sampling unit and raise the pile so it is not matted down. See 6.6 for a description of the dryer. The procedure is as follows:

8.1.1 If fabric softener has recently been used in the dryer, dry a 3.6-kg (8-lb) dummy load of desized unsoftened fabrics which will not be tested, and then repeat this procedure with a different dummy load of 3.6 kg (8 lb) of desized unsoftened fabrics.⁵

8.1.2 Clean the lint filter.

8.1.3 Load the dryer with laboratory sampling units that comprise a homogeneous load (for example, same manufacturer, same line, same finishing, and same previous care). It is not necessary to have a full load in the dryer, so it is acceptable to load only one laboratory sampling unit into the dryer.

8.1.4 Select normal cycle, medium temperature (see Terminology D 3136, and AATCC Test Method 135), and run the dryer for 20 min. Do not use fabric softener during this procedure.

8.1.5 If the laboratory sampling unit(s) was originally damp, keep drying it for 10-min cycles until the fabric(s) is dry to the touch. Do not overdry the fabric(s).

8.2 *Alternate Preparation of the Laboratory Sampling Unit*—The alternate preparation of the laboratory sampling unit uses one cycle of washing and drying. This preconditions the laboratory sampling unit, raises the pile so it is not matted down, and removes some chemicals. Other numbers of washing and drying cycles, such as three or five, may be used. The purchaser and the supplier, however, must agree on the number of washing and drying cycles. This procedure may cause more variation in the test result than

⁵ Dummy loads of fabrics may be comprised of desized unsoftened non-terry fabrics or terry fabrics.

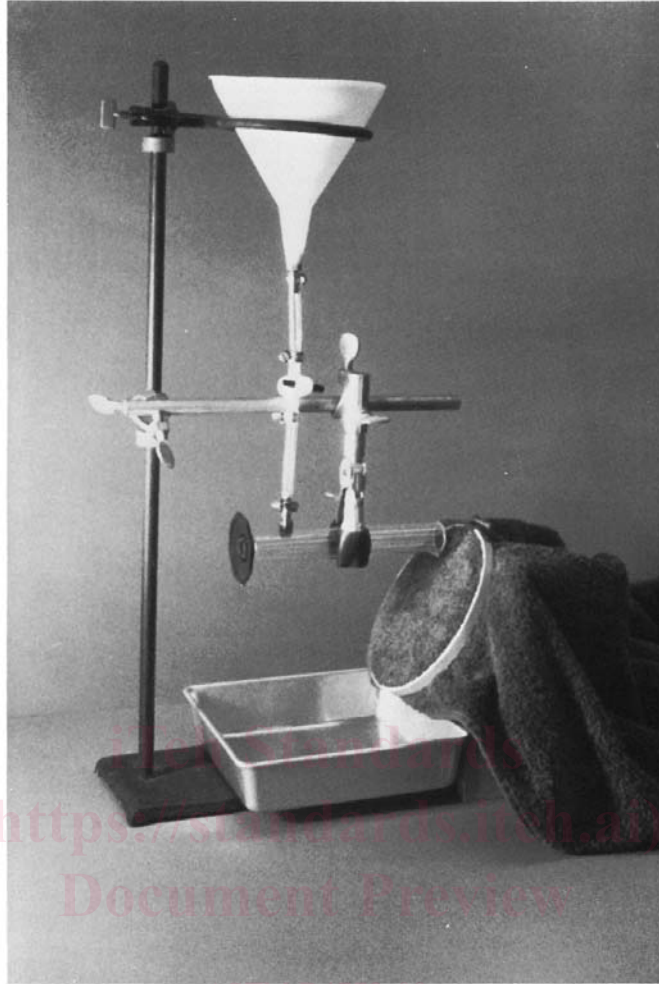

FIG. 3 The Water Flow Tester with the Laboratory Sampling Unit in Place

the procedure described in 8.1 and it is not recommended for acceptance testing unless there has been an agreement between the purchaser and the supplier. This procedure uses the equipment and the supplies described in 6.6-6.8. The procedure is as follows:

8.2.1 If fabric softener has recently been used in the washer or dryer, wash or dry or both a 3.6-kg (8-lb) dummy load of desized unsoftened fabrics which will not be tested, and then repeat this procedure with a different dummy load of 3.6 kg (8 lb) of desized unsoftened fabrics.⁵

8.2.2 If the washer has a lint filter, clean the lint filter.

8.2.3 Load the washer with a 3.6-kg (8-lb) load of laboratory sampling units that comprise a homogeneous load (for example, same manufacturer, same line, same finishing, and same previous care) or a homogeneous group of laboratory sampling units for testing and a desized unsoftened group of dummy fabrics to make a 3.6-kg (8-lb) load.

8.2.4 Select normal cycle, warm water temperature, and The 1993 AATCC Standard Reference Detergent or equivalent detergent (see Terminology D 3136, and AATCC Test Method 135). If agreed upon by the purchaser and the supplier, other detergents and conditions are possible. Run one machine cycle and do not use softener.

8.2.5 Load the dryer with the washed fabrics. Clean the lint filter. Select normal cycle, medium temperature, and run the dryer for 20 min or until the fabrics are dry to the touch. Do not use softener in the dryer. Do not overdry the fabrics.

9. Conditioning

9.1 Both preconditioning and conditioning are required. The dryer in 8.1 and 8.2 will precondition the laboratory sampling unit(s). Conditioning of the laboratory sampling unit(s) is described in 9.2.

9.2 Immediately after taking the laboratory sampling unit(s) out of the dryer, place it in the conditioning room. If the laboratory sampling unit(s) is to be cut to a smaller size agreed upon by the purchaser and the supplier (optional), the laboratory sampling unit(s) must be cut before conditioning. Remove lint from the laboratory sampling unit(s) by lightly brushing the surface with a clothes brush. During conditioning, hang the laboratory sampling unit(s) on a line or rod, or lay it flat on a shelf, or place it on

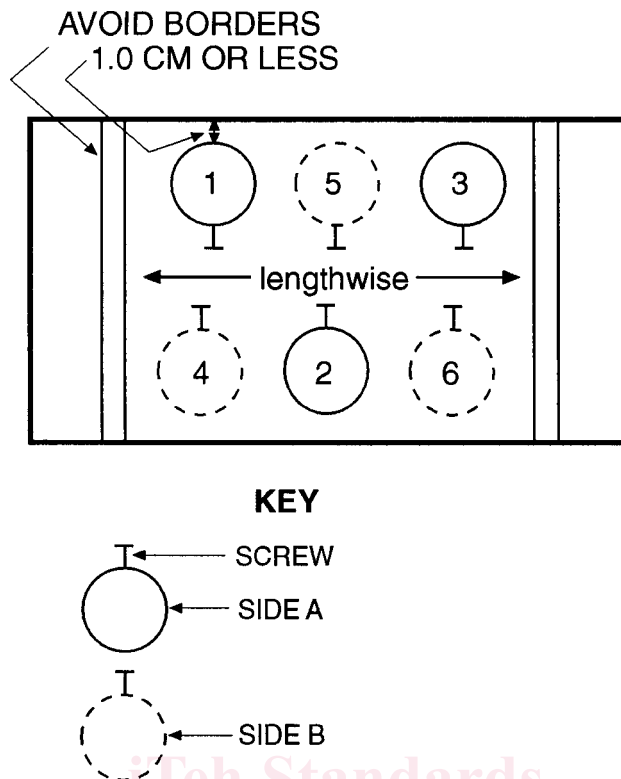

FIG. 4 Location of the Hoop for a Large Laboratory Sampling Unit Such as a Bath Towel

a conditioning rack in a conditioning room so that at least one side is fully exposed to the standard atmosphere for testing textiles, which is 21 ± 1 °C (70 ± 2 °F) and 65 ± 2 % relative humidity. At no time during conditioning should the laboratory sampling unit(s) be folded or stacked. About halfway through conditioning, turn over the laboratory sampling unit(s) so both sides will have had contact with the conditioned air. Allow the laboratory sampling unit(s) to condition for a minimum of 24 h and a maximum of 48 h before testing. The reason for the maximum time is terry fabric is able to pick up excess moisture from humid moving air and thus it can achieve a somewhat damp condition. If the maximum time has been exceeded, the procedure directed in 8.1 and Section 9 must be repeated.

10. Procedure

10.1 Test the conditioned laboratory sampling unit(s) in the standard atmosphere for testing textiles, which is 21 ± 1 °C (70 ± 2 °F) and 65 ± 2 % relative humidity.

10.2 Place the apparatus (Figs. 1-3) on a flat surface where spilled water will not cause a problem.

10.3 With no laboratory sampling unit on the base, pre-wet the graduate attached to the apparatus by using the following procedure. While the valve is in a closed position, pour 50 ± 1 mL of distilled or deionized water at 21 ± 1 °C (70 ± 2 °F) in the graduate which is not attached to the apparatus and then pour this water into the funnel. Open the valve and allow the water to run through the apparatus and into the pan. Thoroughly dry the base, the hoop, and the pan.

10.4 Place the hoop on the laboratory sampling unit so that no more than 1.0 cm (0.39 in.) of the laboratory sampling unit extends past the bottom of the hoop (see Figs. 3 and 4). Do not include borders, hems, stitches, or selvages in the area of the specimen (the area inside the hoop). Position the adjustment screw on the hoop so it will later be in an upward position and it will be visible to the operator (see Figs. 3 and 4). In other words, when the hoop/specimen assembly is later placed on the base and the operator looks at the area of the specimen inside the hoop, an imaginary line that represents the lengthwise (warp or wale) direction of the specimen will be parallel to the table top. Position the specimen in relation to the hoop so that the lengthwise direction of the specimen will be parallel to the table top when the test is conducted (see Figs. 3 and 4). Adjust the adjustment screw to securely hold the fabric in place while being neither tight enough to distort the fabric nor loose enough that the fabric sags. Position the outer ring of the hoop so it is not higher than the specimen and thus it does not trap water between it and the specimen.

10.5 Mount the hoop/specimen assembly on the base. Excess laboratory sampling unit must be allowed to drape over the sides and the back of the base (see Fig. 3).

10.6 Position the hoop/specimen assembly (see Figs. 1 and 3) so that the bottom of the pour spout is 0.6 ± 0.4 cm (0.24 ± 0.16 in.) away from the specimen, 3.0 ± 0.2 cm (1.18 ± 0.08 in.) down from where the adjustment screw bracket joins the outer hoop, and centered between the sides of the hoop.