



SLOVENSKI STANDARD
SIST EN 1459-2:2015+A1:2019
01-april-2019

Vozila za talni transport - Terenska vozila - Varnostne zahteve in preverjanje - 2. del: Vozila z vrtljivim mehanizmom za dviganje s spremenljivim dosegom

Rough-terrain trucks - Safety requirements and verification - Part 2: Slewing variable-reach trucks

Geländegängige Stapler - Sicherheitstechnische Anforderungen und Verifizierung - Teil 2: Schwenkbare Stapler mit veränderlicher Reichweite

Chariots tout-terrain - Prescriptions de sécurité et vérification - Partie 2 : Chariots à portée variable rotatifs

[SIST EN 1459-2:2015+A1:2019](https://standards.iteh.ai/catalog/standards/sist/1e20b7d5-89ad-4562-adb2-5c1e002e597a/sist-en-1459-2-2015a1-2019)

[https://standards.iteh.ai/catalog/standards/sist/1e20b7d5-89ad-4562-adb2-](https://standards.iteh.ai/catalog/standards/sist/1e20b7d5-89ad-4562-adb2-5c1e002e597a/sist-en-1459-2-2015a1-2019)

[5c1e002e597a/sist-en-1459-2-2015a1-2019](https://standards.iteh.ai/catalog/standards/sist/1e20b7d5-89ad-4562-adb2-5c1e002e597a/sist-en-1459-2-2015a1-2019)

Ta slovenski standard je istoveten z: EN 1459-2:2015+A1:2018

ICS:

53.060 Industrijski tovornjaki Industrial trucks

SIST EN 1459-2:2015+A1:2019 en,fr

iTeh STANDARD PREVIEW
(standards.iteh.ai)

SIST EN 1459-2:2015+A1:2019

<https://standards.iteh.ai/catalog/standards/sist/1e20b7d5-89ad-4562-adb2-5c1e002e597a/sist-en-1459-2-2015a1-2019>

EUROPEAN STANDARD

EN 1459-2:2015+A1

NORME EUROPÉENNE

EUROPÄISCHE NORM

October 2018

ICS 53.060

English Version

Rough-terrain trucks - Safety requirements and verification - Part 2: Slewing variable-reach trucks

Chariots tout-terrain - Prescriptions de sécurité et vérification - Partie 2 : Chariots à portée variable rotatifs

Geländegängige Stapler - Sicherheitstechnische Anforderungen und Verifizierung - Teil 2: Schwenkbare Stapler mit veränderlicher Reichweite

This European Standard was approved by CEN on 17 July 2015 and includes Amendment 1 approved by CEN on 7 February 2018.

CEN members are bound to comply with the CEN/CENELEC Internal Regulations which stipulate the conditions for giving this European Standard the status of a national standard without any alteration. Up-to-date lists and bibliographical references concerning such national standards may be obtained on application to the CEN-CENELEC Management Centre or to any CEN member.

This European Standard exists in three official versions (English, French, German). A version in any other language made by translation under the responsibility of a CEN member into its own language and notified to the CEN-CENELEC Management Centre has the same status as the official versions.

CEN members are the national standards bodies of Austria, Belgium, Bulgaria, Croatia, Cyprus, Czech Republic, Denmark, Estonia, Finland, Former Yugoslav Republic of Macedonia, France, Germany, Greece, Hungary, Iceland, Ireland, Italy, Latvia, Lithuania, Luxembourg, Malta, Netherlands, Norway, Poland, Portugal, Romania, Serbia, Slovakia, Slovenia, Spain, Sweden, Switzerland, Turkey and United Kingdom.



EUROPEAN COMMITTEE FOR STANDARDIZATION
COMITÉ EUROPÉEN DE NORMALISATION
EUROPÄISCHES KOMITEE FÜR NORMUNG

CEN-CENELEC Management Centre: Rue de la Science 23, B-1040 Brussels

Contents	Page
European foreword.....	4
Introduction	5
1 Scope.....	6
2 Normative references.....	7
3 Terms and definitions	9
4 Safety requirements and/or protective measures	14
4.1 General.....	14
4.2 Starting/moving	15
4.3 Brakes.....	16
4.4 Electrical and electronic systems.....	16
4.5 Controls.....	17
4.6 Power systems and accessories	23
4.7 Stabilizing devices	24
4.8 Design requirements for maintenance purposes.....	27
4.9 Systems for lifting, tilting, reaching and slewing.....	27
4.10 Operator's station	30
4.11 Operator access.....	36
4.12 Protective measures and devices.....	37
4.13 Stability requirements	38
4.14 Visibility.....	38
4.15 Lighting.....	39
4.16 Fire protection	39
4.17 Retrieval, transportation and lifting.....	39
4.18 Noise	40
4.19 Electromagnetic compatibility	41
4.20 Elastic and rigid body stability / Structural and stability calculations	41
5 Verification of requirements and safety measures	44
5.1 General.....	44
5.2 Functional verification.....	44
5.3 Structural verification	44
5.4 Load holding verification	45
5.5 Maximum load lowering speed verification.....	45
6 Information for use	46
6.1 Signals and warning.....	46
6.2 Instruction handbook.....	48
6.3 Marking.....	51
6.4 Load chart	52
Annex A (informative) List of significant hazards.....	54
Annex B (informative) Consistency of motions	61
Annex C (normative) Rules for the construction and layout of pedals.....	62
C.1 Definitions	62
C.2 Requirements.....	62

C.3	Design and manufacture	63
Annex D (informative)	Regular and occasional loads	65
D.1	General	65
D.2	Regular loads	65
D.3	Occasional loads	65
Annex ZA (informative)	Relationship between this European Standard and the Essential Requirements of EU Directive 2006/42/EC	66
Bibliography		67

iTeh STANDARD PREVIEW (standards.iteh.ai)

[SIST EN 1459-2:2015+A1:2019](https://standards.iteh.ai/catalog/standards/sist/1e20b7d5-89ad-4562-adb2-5c1e002e597a/sist-en-1459-2-2015a1-2019)

<https://standards.iteh.ai/catalog/standards/sist/1e20b7d5-89ad-4562-adb2-5c1e002e597a/sist-en-1459-2-2015a1-2019>

EN 1459-2:2015+A1:2018 (E)**European foreword**

This document (EN 1459-2:2015+A1:2018) has been prepared by Technical Committee CEN/TC 150 "Industrial trucks - Safety", the secretariat of which is held by BSI.

This European Standard shall be given the status of a national standard, either by publication of an identical text or by endorsement, at the latest by April 2019, and conflicting national standards shall be withdrawn at the latest by April 2019.

Attention is drawn to the possibility that some of the elements of this document may be the subject of patent rights. CEN shall not be held responsible for identifying any or all such patent rights.

This document includes Amendment 1 approved by CEN on 7 February 2018.

This document supersedes EN 1459-2:2015.

The start and finish of text introduced or altered by amendment is indicated in the text by tags **A1** **A1**.

This document has been prepared under a mandate given to CEN by the European Commission and the European Free Trade Association, and supports essential requirements of EU Directive(s).

For relationship with EU Directive(s), see informative Annex ZA, which is an integral part of this document.

EN 1459, *Rough-terrain trucks — Safety requirements and verification*, consists of the following parts:

- *Part 1: Variable-reach trucks* [SIST EN 1459-2:2015+A1:2019](https://standards.iteh.ai/catalog/standards/sist/1e20b7d5-89ad-4562-adb2-5c1e002e597a/sist-en-1459-2-2015a1-2019)
- *Part 2: Slewing variable-reach trucks*
- *Part 3: Interface between the variable-reach truck and the work platform*
- *Part 4: Additional requirements for variable reach trucks handling suspended loads*
- *Part 5: Additional requirements for attachments and attachment interface*
- *Part 6: Risk assessment methodology and control system performance level determination (CEN/TR)*
- *Part 7: Test method and determination of noise emission (in development)*

According to the CEN-CENELEC Internal Regulations, the national standards organizations of the following countries are bound to implement this European Standard: Austria, Belgium, Bulgaria, Croatia, Cyprus, Czech Republic, Denmark, Estonia, Finland, Former Yugoslav Republic of Macedonia, France, Germany, Greece, Hungary, Iceland, Ireland, Italy, Latvia, Lithuania, Luxembourg, Malta, Netherlands, Norway, Poland, Portugal, Romania, Serbia, Slovakia, Slovenia, Spain, Sweden, Switzerland, Turkey and the United Kingdom.

Introduction

This European Standard covers general safety requirements and the means for verification of these requirements for slewing rough-terrain variable-reach trucks.

For the purpose of this European Standard, slewing rough-terrain variable-reach trucks are primarily designed to transport and place loads to elevated work areas and can be driven on unimproved terrain.

Trucks may also be equipped with a variety of attachments, e.g., mower, sweeper.

All quantities are in SI units, and this includes metric units.

Acknowledging that, at the time of publication, the requirements included in this European Standard do not represent the state of the art, a transition period of 18 months is permitted after the date of publication, such that manufacturers can develop their products sufficiently to meet the requirements of this European Standard.

This document is a type C standard as stated in EN ISO 12100.

The machinery concerned and the extent to which hazards, hazardous situations and hazardous events are covered are indicated in the scope of this document.

When provisions of this type C standard are different from those which are stated in type A or B standards, the provisions of this type C standard take precedence over the provisions of the other standards, for machines that have been designed and built according to the provisions of this type C standard.

iTeh STANDARD PREVIEW
(standards.iteh.ai)

[SIST EN 1459-2:2015+A1:2019](https://standards.iteh.ai/catalog/standards/sist/1e20b7d5-89ad-4562-adb2-5c1e002e597a/sist-en-1459-2-2015a1-2019)

<https://standards.iteh.ai/catalog/standards/sist/1e20b7d5-89ad-4562-adb2-5c1e002e597a/sist-en-1459-2-2015a1-2019>

EN 1459-2:2015+A1:2018 (E)**1 Scope**

This European Standard specifies the general safety requirements of slewing variable-reach rough-terrain trucks (here-after referred to as trucks), consisting of a lower chassis with a slewing upper structure equipped with a telescopic lifting means (pivoted boom), on which a load handling device (e.g. carriage and fork arms) is typically fitted.

Fork arms are covered by this European Standard and considered to be parts of the truck.

This European Standard deals with all significant hazards, hazardous situations and events relevant to the trucks when they are used as intended and under conditions of misuse which are reasonably foreseeable by the manufacturer (see Annex A).

This European Standard does not apply to:

- variable-reach rough terrain trucks covered by **A1** EN 1459-1 **A1** (non-slewing);
- industrial variable-reach trucks (covered by **A1** EN ISO 3691-2 **A1**);
- lorry-mounted variable-reach trucks;

A1 *deleted text* **A1**

- mobile cranes (covered by EN 13000);
- machines designed primarily for earth moving, such as loaders and dozers, even if their buckets and blades are replaced with forks (see EN 474 series);
- trucks designed primarily with variable length load suspension elements (e.g., chain, ropes) from which the load may swing freely in all directions;
- trucks designed primarily for container handling;
- trucks on tracks;
- attachments (prEN 1459-5).

This European Standard does not address hazards linked to:

- hybrid power systems;
- gas power system;
- trucks equipped with gasoline engine;
- battery power system;
- tractor specific devices (e.g. PTO);
- **A1** tilting or elevating operator position. **A1**

This European Standard does not address hazards which may occur when:

- a) handling suspended loads which may swing freely (additional requirements are given in prEN 1459-4);
- b) using trucks on public roads;

- c) operating in potentially explosive atmospheres;
- d) operating underground;
- e) when towing trailers;
- f) fitted with a personnel work platform (additional requirements are given in EN 1459-3).

2 Normative references

The following documents, in whole or in part, are normatively referenced in this document and are indispensable for its application. For dated references, only the edition cited applies. For undated references, the latest edition of the referenced document (including any amendments) applies.

EN 842:1996+A1:2008, *Safety of machinery – Visual danger signals – General requirements, design and testing*

EN 1175-2:1998+A1:2010, *Safety of industrial trucks – Electrical requirements – Part 2: General requirements of internal combustion engine powered trucks*

EN 12053:2001+A1:2008, *Safety of industrial trucks – Test methods for measuring noise emissions*

EN 12895:2015, *Industrial trucks – Electromagnetic compatibility*

EN 13059:2001+A1:2008, *Safety of industrial trucks – Test methods for measuring vibration*

EN 13309:2010, *Construction machinery – Electromagnetic compatibility of machines with internal power supply*

EN 60529:1991, *Degrees of protection provided by enclosures (IP Code) (IEC 60529)*

EN 62061:2005, *Safety of machinery – Functional safety of safety-related electrical, electronic and programmable electronic control systems (IEC 62061:2003)*

EN ISO 2860:2008, *Earth-moving machinery – Minimum access dimensions (ISO 2860:1992)*

EN ISO 2867:2011, *Earth-moving machinery – Access systems (ISO 2867:2011)*

EN ISO 3164:2013, *Earth-moving machinery – Laboratory evaluations of protective structures – Specifications for deflection-limiting volume (ISO 3164:2013)*

EN ISO 3411:2007, *Earth-moving machinery – Physical dimensions of operators and minimum operator space envelope (ISO 3411:2007)*

EN ISO 3449:2008, *Earth-moving machinery – Falling-object protective structures – Laboratory tests and performance requirements (ISO 3449:2005)*

EN ISO 3457:2008, *Earth-moving machinery – Guards – Definitions and requirements (ISO 3457:2003)*

EN ISO 3471:2008, *Earth-moving machinery – Roll-over protective structures – Laboratory tests and performance requirements (ISO 3471:2008)*

EN ISO 4413:2010, *Hydraulic fluid power – General rules and safety requirements for systems and their components (ISO 4413:2010)*

EN 1459-2:2015+A1:2018 (E)

EN ISO 4414:2010, *Pneumatic fluid power – General rules and safety requirements for systems and their components (ISO 4414:2010)*

EN ISO 5353:1998, *Earth-moving machinery, and tractors and machinery for agriculture and forestry – Seat index point (ISO 5353:1995)*

EN ISO 6682:2008, *Earth-moving machinery – Zones of comfort and reach for controls (ISO 6682:1986, including Amd 1:1989)*

EN ISO 6683:2008, *Earth-moving machinery – Seat belts and seat belt anchorages – Performance requirements and tests (ISO 6683:2005)*

EN ISO 7096:2008, *Earth-moving machinery – Laboratory evaluation of operator seat vibration (ISO 7096:2000)*

EN ISO 12100:2010, *Safety of machinery – General principles for design – Risk assessment and risk reduction (ISO 12100:2010)*

EN ISO 13732-1:2008, *Ergonomics of the thermal environment – Methods for the assessment of human responses to contact with surfaces – Part 1: Hot surfaces (ISO 13732-1:2006)*

EN ISO 13849-1:2008, *Safety of machinery – Safety-related parts of control systems – Part 1: General principles for design (ISO 13849-1:2006)*

EN ISO 13850:2008, *Safety of machinery – Emergency stop – Principles for design (ISO 13850:2006)*

EN ISO 13857:2008, *Safety of machinery – Safety distances to prevent hazard zones being reached by upper and lower limbs (ISO 13857:2008)*

ISO 3795:1989, *Road vehicles, and tractors and machinery for agriculture and forestry – Determination of burning behaviour of interior materials*

ISO 4305:2014, *Mobile cranes – Determination of stability*

ISO 5053-1:2014, *Industrial trucks - Terminology and classification - Part 1: Types of industrial trucks*

ISO 6011:2003, *Earth-moving machinery – Visual display of machine operation*

ISO 6016:2008, *Earth-moving machinery – Methods of measuring the masses of whole machines, their equipment and components*

ISO 6292:2008, *Powered industrial trucks and tractors – Brake performance and component strength*

ISO 7000:2014, *Graphical symbols for use on equipment – Registered symbols*

ISO 9533:2010, *Earth-moving machinery – Machine-mounted audible travel alarms and forward horns – Test methods and performance criteria*

ISO 10263-2:2009, *Earth-moving machinery – Operator enclosure environment – Part 2: Air filter element test method*

ISO 10263-3:2009, *Earth-moving machinery – Operator enclosure environment – Part 3: Pressurization test method*

ISO 10263-4:2009, *Earth-moving machinery – Operator enclosure environment – Part 4: Heating, ventilating and air conditioning (HVAC) test method and performance*

- ISO 10896-1:2012, *Rough-terrain trucks — Safety requirements and verification — Part 1: Variable-reach trucks*
- ISO 11112:1995, *Earth-moving machinery — Operator's seat — Dimensions and requirements*
- ISO 11862:1993, *Earth-moving machinery — Auxiliary starting aid electrical connector*
- ISO 12508:1994, *Earth-moving machinery — Operator station and maintenance areas — Bluntness of edges*
- ISO 12509:2004, *Earth-moving machinery — Lighting, signalling and marking lights, and reflex-reflector devices*
- ISO 13333:1994, *Earth-moving machinery — Dumper body support and operator's cab tilt support devices*
- ISO 15817:2012, *Earth-moving machinery — Safety requirements for remote operator control systems*
- ISO/DIS 15818:2014, *Earth-moving machinery — Lifting and tying-down attachment points — Performance requirements*
- ISO 21507:2010, *Earth-moving machinery — Performance requirements for non-metallic fuel tanks*
- ISO 22915-10:2008, *Industrial trucks — Verification of stability — Part 10: Additional stability test for trucks operating in the special condition of stacking with load laterally displaced by powered devices*
- ISO 22915-20:2008, *Industrial trucks — Verification of stability — Part 20: Additional stability test for trucks operating in the special condition of offset load, offset by utilization*
- ISO 22915-24:2015, *Industrial trucks — Verification of stability — Part 24: Slewing variable-reach rough-terrain trucks*

3 Terms and definitions

For the purposes of this document, the terms and definitions given in EN ISO 12100:2010 and ISO 5053-1:2014 and the following apply.

3.1

slewing rough terrain variable reach truck

rough terrain variable reach truck with an upper structure which can rotate around a vertical axis of the chassis in a circular motion greater than 5° either side of the longitudinal axis of the truck

[SOURCE: ISO 5053-1:2014, 3.22]

3.2

actual capacity (Q)

maximum load, established by the manufacturer based on component strength and truck stability, that the truck can carry, lift and stack to a specified height, at a specified standard load centre distance and reach, in normal operating conditions

Note 1 to entry: The actual capacity depends on the configuration of the truck in terms of such variables as:

- lift height;
- reach of the boom (measured from the centre of slewing of the rotating upper structure);

EN 1459-2:2015+A1:2018 (E)

- slewing position;
- standard load centre distance;
- load handling device (fork arms or attachment fitted);
- stabilizing devices.

Note 2 to entry: This actual capacity defines the load handling ability of the particular truck as equipped. Additional actual capacity ratings with removable attachments may also be established where permitted by the appropriate stability test or by calculation verified by empirical data.

3.3

reach (d)

normal distance between the axis of rotation of the upper structure and the vertical plane including G perpendicular to the longitudinal axis of the upper structure

Note 1 to entry: The centre-of-gravity of the load (G) is defined in Table 1.

Note 2 to entry: See Figure 1 for examples of reach.

Note 3 to entry: For practical matters, d can be measured referring to point g , being g the vertical projection of the centre-of-gravity (G) of the load onto the plane of the top surface of the fork arms.

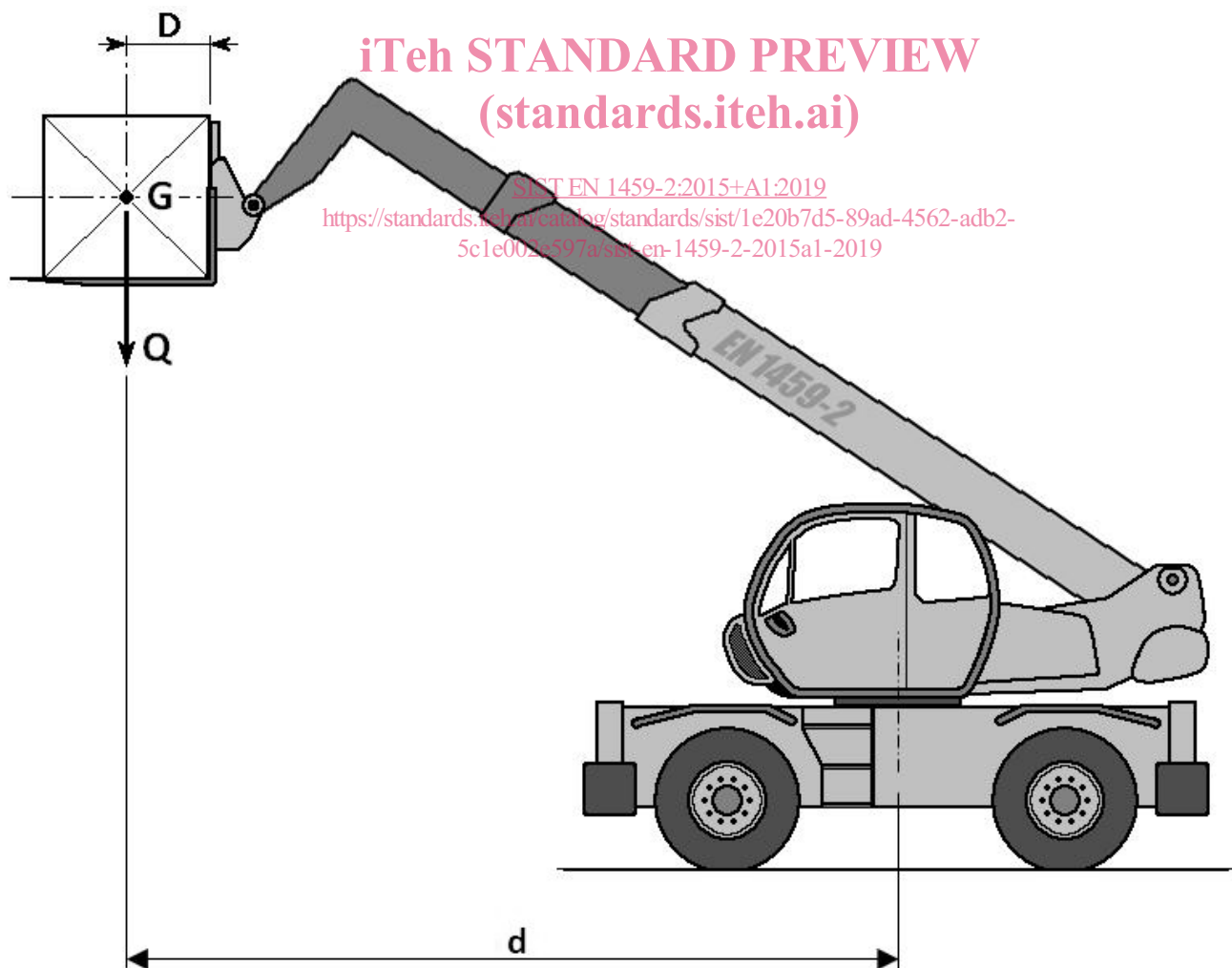

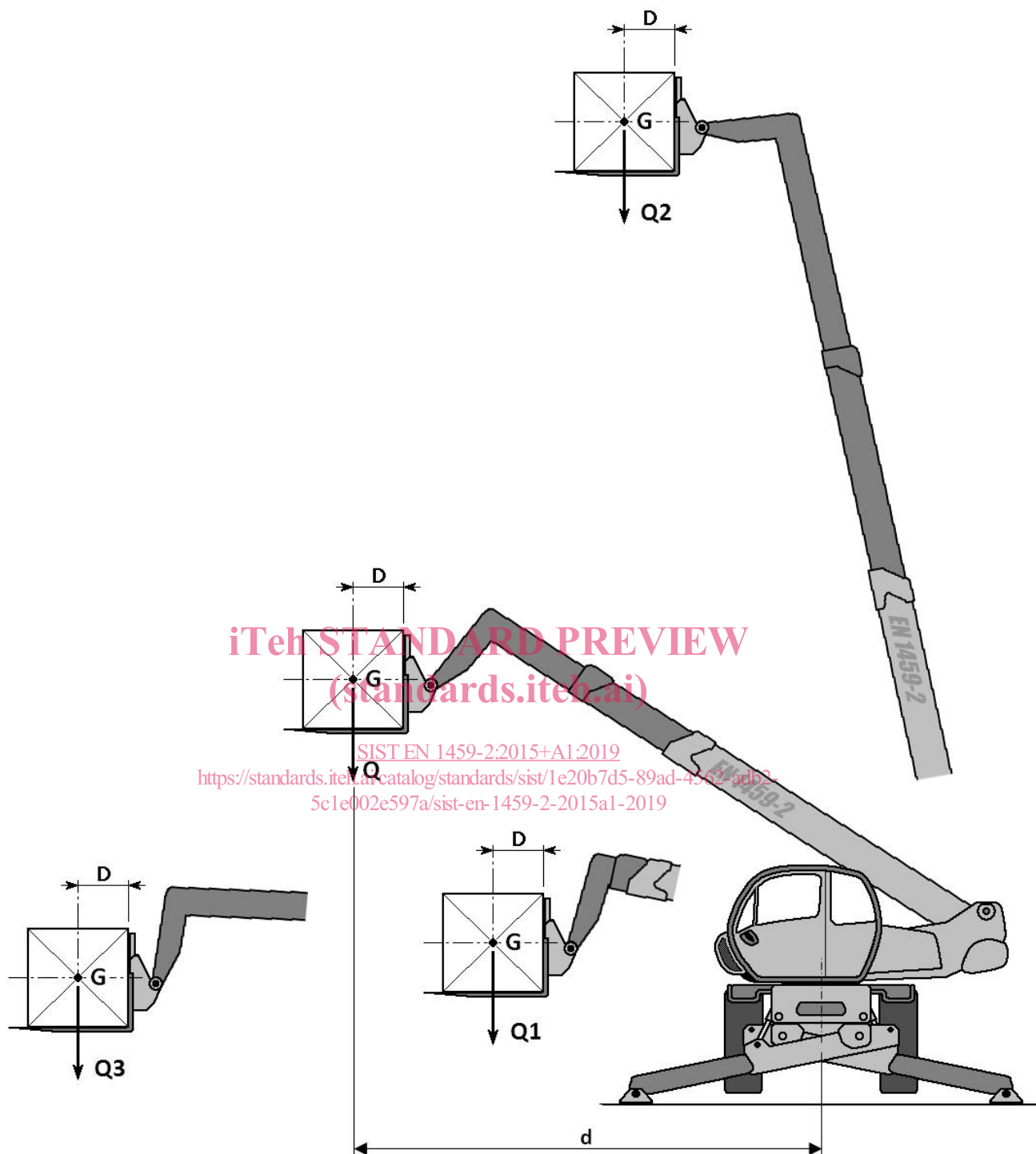
**Key**

- d reach
- D standard load centre distance
- G centre of gravity of the load
- Q actual capacity
- Q1 rated capacity
- Q2 rated capacity at maximum height or elevation
- Q3 rated capacity at maximum reach

Figure 1 — Parameters for the designation of the actual capacity of the truck with fork

EN 1459-2:2015+A1:2018 (E)

3.4

lift height (H)

vertical distance between the upper face of the fork arms and the ground

3.5

standard load centre distance (D)

distance from the centre of gravity (G) of the load measured horizontally back to the fronts of the fork shanks and vertically down to the upper faces of the fork arms, as specified in Table 1

Note 1 to entry: See Figure 1 for example.

Note 2 to entry: Typical standard load centre distances are given in Table 1.

Table 1 — Typical standard load centre distance

Rated capacity Q in kg		Standard load centre distance D in mm				
		400	500	600	900	1 200
0	< 1 000	X				
≥ 1 000	< 5 000		X			
≥ 5 000	≤ 10 000			X		
> 10 000	< 20 000			X	X	X
≥ 20 000	< 25 000				X	X
≥ 25 000						X

Note 3 to entry: Trucks may be rated for special applications with load centres related to those applications.

3.6

attachment

either a tool or an interchangeable equipment, which can be attached to the lifting equipment

3.7

rated capacity of attachments

maximum load that the attachment is permitted by its manufacturer to handle under specified conditions

Note 1 to entry: The rated capacity of the attachment can be associated with the load centre distance.

3.8

axle oscillation lock

mechanism designed to prevent oscillation of an axle to improve truck stability

3.9

stabilizing devices

extendable and/or pivoting mechanical supports used to improve stability of a truck when stationary

3.10

adjustable levelling

setting the plane inclination angle between the chassis and the ground to ensure the boom operates in a vertical plane when the truck is positioned on a slope

3.11

forks

device comprising two or more solid fork arms, each consisting of a shank (vertical portion) and blade, which is hook- or shaft-mounted, fitted on the carriage and usually adjusted manually

3.12**boom**

pivoting support member that permits horizontal and vertical positioning of the load or attachment

3.13**crab steering mode**

steering mode where all wheels of the truck steer in the same direction

3.14**normal operator's position**

position as specified by the manufacturer in which the operator is able to control the truck operations, including load handling functions

[SOURCE: ISO 10896-1:2012, 3.16]

Note 1 to entry: Other positions may be necessary if it is not possible to control all the functions of the truck from a single position.

3.15**attachment bracket**

device fitted at the end of the boom to mount interchangeable attachments to facilitate quick interchange of attachment

3.16**boom float**

control mode that uses gravity to allow an attachment at the end of the boom to follow a contour (e.g. the ground)

3.17**maximum working pressure**

maximum pressure in the hydraulic circuit during normal operation

[SOURCE: ISO 10972-3:2003, 3.2]

3.18**rated capacity (Q1)**

maximum load permitted by the manufacturer at the standard load centre distance (D) that the truck is capable of lifting and transporting on fork arms in normal conditions with the boom fully retracted

3.19**interchangeable equipment**

device which is assembled with the truck by the operator himself in order to change its function or to attribute a new function

3.20**tool**

device which is assembled with the lifting equipment by the operator himself and that does not change its function

3.21**aligned position**

configuration of the truck in which the longitudinal mid-axis of the slewing upper structure is aligned with the longitudinal mid-axis of the chassis

iTeh STANDARD PREVIEW
(standards.iteh.ai)

SIST EN 1459-2:2015+A1:2019

<https://standards.iteh.ai/catalog/standards/sist/1e20b7d5-89ad-4562-adb2-10972-3>