



**SLOVENSKI STANDARD**  
**SIST EN 12255-9:2024**

**01-januar-2024**

**Nadomešča:**  
**SIST EN 12255-9:2002**

---

**Čistilne naprave za odpadno vodo – 9. del: Kontrola vonja in prezračevanje**

Wastewater treatment plants - Part 9: Odour control and ventilation

Kläranlagen - Teil 9: Geruchsminderung und Belüftung

Stations d'épuration - Partie 9 : Maîtrise des odeurs et ventilation

**Ta slovenski standard je istoveten z: EN 12255-9:2023**

---

<https://standards.iteh.ai/catalog/standards/sist/76816f3c-60cd-4f19-96e0-3f2ed0d22caa/sist-en-12255-9-2024>  
**ICS:** 13.060.30      Odpadna voda      Sewage water

**SIST EN 12255-9:2024**

**en,fr,de**



EUROPEAN STANDARD  
NORME EUROPÉENNE  
EUROPÄISCHE NORM

**EN 12255-9**

November 2023

ICS 13.060.30

Supersedes EN 12255-9:2002

English Version

**Wastewater treatment plants - Part 9: Odour control and  
ventilation**

Stations d'épuration - Partie 9 : Maîtrise des odeurs et  
ventilation

Kläranlagen - Teil 9: Geruchsminderung und Belüftung

This European Standard was approved by CEN on 29 October 2023.

CEN members are bound to comply with the CEN/CENELEC Internal Regulations which stipulate the conditions for giving this European Standard the status of a national standard without any alteration. Up-to-date lists and bibliographical references concerning such national standards may be obtained on application to the CEN-CENELEC Management Centre or to any CEN member.

This European Standard exists in three official versions (English, French, German). A version in any other language made by translation under the responsibility of a CEN member into its own language and notified to the CEN-CENELEC Management Centre has the same status as the official versions.

CEN members are the national standards bodies of Austria, Belgium, Bulgaria, Croatia, Cyprus, Czech Republic, Denmark, Estonia, Finland, France, Germany, Greece, Hungary, Iceland, Ireland, Italy, Latvia, Lithuania, Luxembourg, Malta, Netherlands, Norway, Poland, Portugal, Republic of North Macedonia, Romania, Serbia, Slovakia, Slovenia, Spain, Sweden, Switzerland, Türkiye and United Kingdom.

Document Preview

[SIST EN 12255-9:2024](https://standards.iteh.ai/SIST/EN/12255-9/2024)

<https://standards.iteh.ai/catalog/standards/sist/76816f3c-60cd-4f19-96e0-3f2ed0d22caa/sist-en-12255-9-2024>



EUROPEAN COMMITTEE FOR STANDARDIZATION  
COMITÉ EUROPÉEN DE NORMALISATION  
EUROPÄISCHES KOMITEE FÜR NORMUNG

**CEN-CENELEC Management Centre: Rue de la Science 23, B-1040 Brussels**

| <b>Contents</b>   | <b>Page</b> |
|---|-------------|
| European foreword .....   | 3           |
| Introduction .....  | 5           |
| 1 Scope.....  | 6           |
| 2 Normative references.....   | 6           |
| 3 Terms and definitions.....  | 6           |
| 4 Symbols and abbreviations .....   | 9           |
| 5 Design principles .....   | 9           |
| 5.1 General.....  | 9           |
| 5.2 Sources and nature of odours.....   | 10          |
| 5.3 Odour measurement.....  | 11          |
| 5.4 Planning .....  | 12          |
| 5.4.1 Preliminary considerations .....  | 12          |
| 5.4.2 Detailed planning.....  | 13          |
| 5.4.3 Criteria for selection.....   | 14          |
| 5.5 Design requirements .....   | 15          |
| 5.5.1 General.....  | 15          |
| 5.5.2 Materials selection .....   | 15          |
| 5.5.3 Chemical or biological addition.....  | 15          |
| 5.5.4 Treatment of odorous air.....   | 16          |
| 5.5.5 Design of covers.....   | 19          |
| 5.5.6 Design of ventilation.....  | 20          |
| 5.6 Process requirements .....  | 20          |
| Annex A (informative) Odour potential and odour emission capacity, measurement of odour<br>emission rate..... | 21          |
| A.1 Odour potential and odour emission capacity.....  | 21          |
| A.2 Measurement of odour emission rate .....  | 21          |
| Bibliography .....  | 23          |

## European foreword

This document (EN 12255-9:2023) has been prepared by Technical Committee CEN/TC 165 “Waste water engineering” the secretariat of which is held by DIN.

This European Standard shall be given the status of a national standard, either by publication of an identical text or by endorsement, at the latest by May 2024, and conflicting national standards shall be withdrawn at the latest by May 2024.

Attention is drawn to the possibility that some of the elements of this document may be the subject of patent rights. CEN shall not be held responsible for identifying any or all such patent rights.

This document supersedes EN 12255-9:2002.

The main changes compared to the previous edition EN 12255-9:2002 are listed below:

- comprehensive revision and additions in all sections;
- adaptation to the current state of the art;
- updating of the Normative references;
- updated bibliography;
- editorial revision.

It is the ninth part prepared by Working Group CEN/TC 165/WG 40 relating to the general requirements and processes for treatment plants for a total number of inhabitants and population equivalents (PE) over 50. The EN 12255 series with the generic title “Wastewater treatment plants” consists of the following parts:

- *Part 1: General construction principles*
- *Part 3: Preliminary treatment*
- *Part 4: Primary settlement*
- *Part 5: Lagooning processes*
- *Part 6: Activated sludge process*
- *Part 7: Biological fixed-film reactors*
- *Part 8: Sludge treatment and storage*
- *Part 9: Odour control and ventilation*
- *Part 10: Safety principles*
- *Part 11: General data required*
- *Part 12: Control and automation*

**EN 12255-9:2023 (E)**

- *Part 13: Chemical treatment — Treatment of wastewater by precipitation/flocculation*
- *Part 14: Disinfection*
- *Part 15: Measurement of the oxygen transfer in clean water in aeration tanks of activated sludge plants*
- *Part 16: Physical (mechanical) filtration*

NOTE For requirements on pumping installations at wastewater treatment plants see EN 752, *Drain and sewer systems outside buildings — Sewer system management* and EN 16932 (all parts), *Drain and sewer systems outside buildings — Pumping systems*.

Any feedback and questions on this document should be directed to the users' national standards body. A complete listing of these bodies can be found on the CEN website.

According to the CEN-CENELEC Internal Regulations, the national standards organisations of the following countries are bound to implement this European Standard: Austria, Belgium, Bulgaria, Croatia, Cyprus, Czech Republic, Denmark, Estonia, Finland, France, Germany, Greece, Hungary, Iceland, Ireland, Italy, Latvia, Lithuania, Luxembourg, Malta, Netherlands, Norway, Poland, Portugal, Republic of North Macedonia, Romania, Serbia, Slovakia, Slovenia, Spain, Sweden, Switzerland, Türkiye and the United Kingdom.

**iTeh Standards**  
**(<https://standards.itih.ai>)**  
**Document Preview**

[SIST EN 12255-9:2024](https://standards.itih.ai/catalog/standards/sist/76816f3c-60cd-4f19-96e0-3f2ed0d22caa/sist-en-12255-9-2024)

<https://standards.itih.ai/catalog/standards/sist/76816f3c-60cd-4f19-96e0-3f2ed0d22caa/sist-en-12255-9-2024>

## Introduction

Differences in wastewater treatment throughout Europe have led to a variety of systems being developed. This document gives fundamental information about the systems; this document has not attempted to specify all available systems. A generic arrangement of wastewater treatment plants is illustrated in Figure 1:

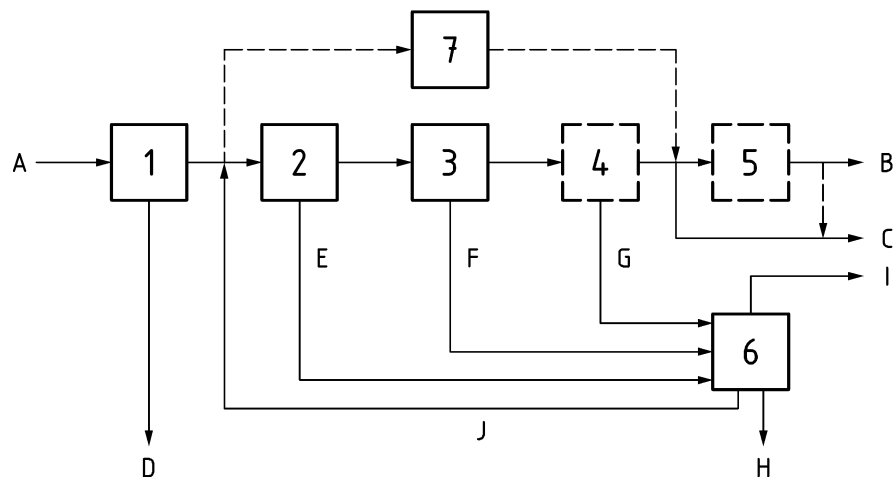

### Key

|  |                                  |
|--|----------------------------------|
| 1 preliminary treatment  | C discharged effluent            |
| 2 primary treatment  | D screenings and grit            |
| 3 secondary treatment  | E primary sludge                 |
| 4 tertiary treatment   | F secondary sludge               |
| 5 additional treatment (e.g. disinfection or removal of micropollutants) | G tertiary sludge                |
| 6 sludge treatment   | H digested sludge                |
| 7 lagoons (as an alternative)  | I digester gas                   |
| A raw wastewater   | J returned water from dewatering |
| B effluent for re-use (e.g. irrigation)                                  |                                  |

**Figure 1 — Schematic diagram of wastewater treatment plants**

Detailed information additional to that contained in this document can be obtained by referring to the bibliography.

The primary application is for wastewater treatment plants designed for the treatment of domestic and municipal wastewater.

**EN 12255-9:2023 (E)****1 Scope**

This document specifies design principles and performance requirements for odour control and associated ventilation for wastewater treatment plants serving more than 50PT.

**2 Normative references**

The following documents are referred to in the text in such a way that some or all of their content constitutes requirements of this document. For dated references, only the edition cited applies. For undated references, the latest edition of the referenced document (including any amendments) applies.

EN 12255-14, *Wastewater treatment plants — Part 14: Disinfection*

EN 13725:2022, *Stationary source emissions — Determination of odour concentration by dynamic olfactometry and odour emission rate*

EN 16323:2014, *Glossary of wastewater engineering terms*

EN 16841-1, *Ambient air — Determination of odour in ambient air by using field inspection — Part 1: Grid method*

EN 16841-2:2016, *Ambient air — Determination of odour in ambient air by using field inspection — Part 2: Plume method*

ISO 1629, *Rubber and latices — Nomenclature*

**3 Terms and definitions**

For the purposes of this document, the terms and definitions given in EN 16323 and the following apply.

ISO and IEC maintain terminology databases for use in standardization at the following addresses:

— ISO Online browsing platform: available at <https://www.iso.org/obp>

— IEC Electropedia: available at <https://www.electropedia.org/>

**3.1****olfactometry**

measurement of the response of assessors to olfactory stimuli

[SOURCE: EN 16323:2014, 2.1.3.2]

Note 1 to entry: See EN 13725 for details.



**3.2****odour concentration**

number of European odour units in a cubic metre of gas at standard conditions for olfactometry

[SOURCE: EN 13725:2022, 3.1.30 but with added example and notes]

**EXAMPLE** If a sample needs to be diluted by a factor of 300 to reach the detection threshold, the odour concentration of the sample is  $c_{od} = 300 \text{ ou}_E/\text{m}^3$ .

Note 1 to entry: The odour concentration has the symbol  $c_{od}$  and the unit  $\text{ou}_E/\text{m}^3$ .

Note 2 to entry: The value of the odour concentration is the dilution factor that is necessary to reach the detection threshold. At the detection threshold, the odour concentration of the mixture is  $1 \text{ ou}_E/\text{m}^3$  by definition.

**3.3****odour emission rate****odour flow rate**

quantity of European odour units which crosses a given surface per unit of time

Note 1 to entry: For point sources, the surface is the sampling plane. The odour flow rate is calculated as the product of the odour concentration  $c_{od}$ , the outlet velocity  $v$  and the area of the sampling plane  $A$  or as the product of the odour concentration  $c_{od}$  and the pertinent volume flow rate  $V$ .

Note 2 to entry: The unit of odour flow rate is  $\text{ou}_E/\text{s}$  (or  $\text{ou}_E/\text{min}$  or  $\text{ou}_E/\text{h}$ ).

Note 3 to entry: The odour flow rate, expressed in  $\text{ou}_E/\text{s}$ , is the quantity equivalent to the mass flow rate, expressed in  $\text{kg}/\text{s}$ , as used in dispersion models for example.

Note 4 to entry: Diffuse sources such as unaerated wastewater or sludge surfaces, do not have a defined waste air flow, although they can emit odorants. In these cases, a special sampling procedure is necessary which is discussed in EN 13725 (see Annex A). Odorant flow rates can be used in an analogous fashion to mass flow rates when modelling the impact from a source. All odour sources will have an odorant flow rate, even where no air flow rate is easily identifiable.

[SOURCE: EN 13725:2022, 3.2.8 modified by the addition of Note 4]

**3.4****volatile organic compound****VOC**

organic compound with an initial boiling point less than or equal to  $250 \text{ }^\circ\text{C}$  measured at a standard pressure of  $101,3 \text{ kPa}$

[SOURCE: EU Directive 2004/42/CE]

**3.5****capital expenditure****CAPEX**

money used to purchase and install and commission a capital asset

[SOURCE: ISO 15663-1:2000, 2.1.6]

**EN 12255-9:2023 (E)****3.6****operational expenditure****OPEX**

recurrent expenditure required to provide a service or product

[SOURCE: ISO/TS 55010:2019, 3.9]

**3.7****empty bed residence time****EBRT**

total time air is retained in a considered unit in average conditions

Note 1 to entry: The EBRT is calculated as  $V/Q$ , where  $V$  (m<sup>3</sup>) is the total internal volume of the unit and  $Q$  (m<sup>3</sup>/s) is the air flow rate. The EBRT calculation assumes that the unit is empty, regardless the presence of packings or other solid elements.

**3.8****specific ozone demand**

required ozone concentration in the odours air (g O<sub>3</sub>/m<sup>3</sup> or g O<sub>3</sub>/l) to achieve a level of odour reduction

**3.9****contact tank**

tank for providing the required retention time for certain reactions to take place

[SOURCE: EN 16323:2014, term 2.3.9.4, modified – definition was modified to extend to use with gases]

**3.10****advanced oxidation process****AOP**

chemical process generating hydroxyl or oxygen radicals

**3.11****UV efficiency****UV-C radiation conversion efficiency**

ability of a UV-C lamp to convert electrical power into UV-C radiation

Note 1 to entry: The ratio is the UV-C radiation power accounting for the electrical power of the UV-C lamp. The UV-C conversion efficiency of a low pressure UV-C lamp at 253,7 nm is between 25 % and 45 %. The UV-C conversion efficiency should not be less than 30 % in an air disinfection field under all circumstances due to energy consumption of the system.

[SOURCE: ISO 15727:2020, 3.6]

**3.12****UV radiation demand**

sum of the UV output (W) at 254 nm from all the lamps of an UV reactor, divided by the odorous air flow rate (m<sup>3</sup>/h) to achieve a certain level of disinfection

Note 1 to entry: The UV output from a lamp is measured according to ISO 15727.