



SLOVENSKI STANDARD

SIST EN 1400:2013+A2:2018

01-oktober-2018

Nadomešča:

SIST EN 1400:2013+A1:2014

Izdelki za otroke - Duge za dojenčke in mlajše otroke - Varnostne zahteve in preskusne metode (z dopolnili do vključno A2)

Child use and care articles - Soothers for babies and young children - Safety requirements and test methods

Artikel für Säuglinge und Kleinkinder - Schnuller für Säuglinge und Kleinkinder - Sicherheitstechnische Anforderungen und Prüfverfahren

Articles de puériculture - Sucettes pour nourrissons et jeunes enfants - Exigences de sécurité et méthodes d'essai

ITih STANDARD PREVIEW
(standards.iteh.ai)
EN 1400:2013+A2:2018
<https://standards.iteh.ai/catalog/standards/sist/10bffc4b-d0c8-43d6-a802-5db5642848c4/sist-en-1400-2013a2-2018>

Ta slovenski standard je istoveten z: EN 1400:2013+A2:2018

ICS:

97.190 Otroška oprema Equipment for children

SIST EN 1400:2013+A2:2018 en,fr,de

iTeh STANDARD PREVIEW
(standards.iteh.ai)

[SIST EN 1400:2013+A2:2018](#)

<https://standards.iteh.ai/catalog/standards/sist/10bffe4b-d0c8-43d6-a802-5db5642848c4/sist-en-1400-2013a2-2018>

EUROPEAN STANDARD

EN 1400:2013+A2

NORME EUROPÉENNE

EUROPÄISCHE NORM

September 2018

ICS 97.190

English Version

Child use and care articles - Soothers for babies and young children - Safety requirements and test methods

Articles de puériculture - Sucettes pour nourrissons et jeunes enfants - Exigences de sécurité et méthodes d'essai

Artikel für Säuglinge und Kleinkinder - Schnuller für Säuglinge und Kleinkinder - Sicherheitstechnische Anforderungen und Prüfverfahren

This European Standard was approved by CEN on 25 February 2014 and includes Amendment 1, approved by CEN on 2014-02-25 and Amendment 2, approved by CEN on 2018-04-23.

CEN members are bound to comply with the CEN/CENELEC Internal Regulations which stipulate the conditions for giving this European Standard the status of a national standard without any alteration. Up-to-date lists and bibliographical references concerning such national standards may be obtained on application to the CEN-CENELEC Management Centre or to any CEN member.

This European Standard exists in three official versions (English, French, German). A version in any other language made by translation under the responsibility of a CEN member into its own language and notified to the CEN-CENELEC Management Centre has the same status as the official versions.

CEN members are the national standards bodies of Austria, Belgium, Bulgaria, Croatia, Cyprus, Czech Republic, Denmark, Estonia, Finland, Former Yugoslav Republic of Macedonia, France, Germany, Greece, Hungary, Iceland, Ireland, Italy, Latvia, Lithuania, Luxembourg, Malta, Netherlands, Norway, Poland, Portugal, Romania, Serbia, Slovakia, Slovenia, Spain, Sweden, Switzerland, Turkey and United Kingdom.



EUROPEAN COMMITTEE FOR STANDARDIZATION
COMITÉ EUROPÉEN DE NORMALISATION
EUROPÄISCHES KOMITEE FÜR NORMUNG

CEN-CENELEC Management Centre: Rue de la Science 23, B-1040 Brussels

Contents	Page
European foreword.....	3
Introduction	4
1 Scope.....	5
2 Normative references.....	5
3 Terms and definitions	5
4 Description of a soother	7
5 Test equipment.....	11
6 General.....	18
7 Printing and decals.....	21
8 Construction properties and tests	21
9 Mechanical properties.....	35
10 Chemical requirements and test methods	43
11 Teat protectors	51
12 Consumer packaging.....	53
13 Product information	53
14 Test report.....	55
Annex A (normative) Warnings	57
Annex B (informative) Rationale.....	61
Annex C (informative) Information for products resembling a soother	73
Annex D (informative) Some examples of suitable fixing devices.....	75
Annex E (informative) Soothers — Assessment of compliance with standard — Sampling plan and compliance levels for freshly manufactured samples.....	78
Annex F (informative) A suitable HPLC apparatus and method for determination of 2-Mercaptobenzothiazole (MBT) and antioxidants BHT, 2246, Cyanox 425, Wingstay L and Irganox 1520	79
Annex G (informative) Graphical representation for determining puncture resistance of a teat.....	83
Annex H (informative) A-deviations	84
Bibliography.....	85

European foreword

This document (EN 1400:2013+A2:2018) has been prepared by Technical Committee CEN/TC 252 “Child care articles”, the secretariat of which is held by AFNOR.

This European Standard shall be given the status of a national standard, either by publication of an identical text or by endorsement, at the latest by March 2019, and conflicting national standards shall be withdrawn at the latest by March 2019.

Attention is drawn to the possibility that some of the elements of this document may be the subject of patent rights. CEN shall not be held responsible for identifying any or all such patent rights.

This document includes Amendment 1, approved by CEN on 2014-02-25 and Amendment 2, approved by CEN on 2018-04-23.

This document supersedes $\boxed{A_2}$ EN 1400:2013+A1:2014 $\boxed{A_2}$.

The start and finish of text introduced or altered by amendment is indicated in the text by tags $\boxed{A_1}$ $\boxed{A_1}$ and $\boxed{A_2}$ $\boxed{A_2}$.

This document has been prepared under a mandate (M/264) given to CEN by the European Commission and the European Free Trade Association.

This standard is linked to the General Product Safety Directive (GPSD) but no Annex ZA is needed because GPSD is not a New Approach Directive and does not include Essential Requirements to which such an annex should refer. (standards.iteh.ai)

According to the CEN-CENELEC Internal Regulations, the national standards organisations of the following countries are bound to implement this European Standard: Austria, Belgium, Bulgaria, Croatia, Cyprus, Czech Republic, Denmark, Estonia, Finland, Former Yugoslav Republic of Macedonia, France, Germany, Greece, Hungary, Iceland, Ireland, Italy, Latvia, Lithuania, Luxembourg, Malta, Netherlands, Norway, Poland, Portugal, Romania, Serbia, Slovakia, Slovenia, Spain, Sweden, Switzerland, Turkey and the United Kingdom.

EN 1400:2013+A2:2018 (E)**Introduction**

Soothers are widely used throughout Europe to satisfy non-nutritive sucking needs and to pacify children.

They are designed to be in the mouths of babies and young children for long periods. Accidents, some of which have been fatal, have occurred in the past and a prime purpose of this standard is to reduce the risk of accidents occurring in the future. It is stressed that this European Standard cannot eliminate all possible risks to babies and young children using such a product and that parental or guardian control is of paramount importance. It is essential that all warnings and instructions specified in this standard are given clearly by the manufacturer, to allow the consumer to ensure that the soother is used correctly and safely.

This European Standard harmonises minimum safety requirements and test methods for soothers. Most of the provisions have been taken from other existing national and European Standards.

It is recommended that manufacturers and suppliers operate to EN ISO 9001, the standard for quality management systems [1]. It is also recommended that laboratories operate to ISO/IEC 17025, General requirements for the competence of testing and calibration laboratories [4].

In addition, it is recognised that some organisations require reference testing. A suggested sampling plan and compliance levels for freshly manufactured soothers are provided in Annex E (informative). This procedure can be used as a voluntary type approval procedure.

Latex protein allergy risk has not been included in this standard. Nevertheless, provision for packaging information for soothers containing natural rubber has been made in this standard. There is no published information that sensitisation is caused by soother teats. In addition, there is an extremely low incidence of latex protein allergy among young children and babies. However, the issue of subsequent allergic reaction from rubber teats will be reconsidered when further information becomes available.

Phthalates have not been included in this standard because the use of phthalates in childcare articles is restricted by Annex XVII of REACH Regulation [5].

A normative annex has been included which contains translations of warning phrases into the main European languages.

A₂ Since the publication of EN 1400:2013+A1:2014 it has come to the attention of the Technical Committee that some of the TDI's used to calculate the limits of a certain number of element migration from soothers are out of date. During the drafting of this amendment the Technical committee reviewed all the previous sources of TDI's to ascertain the current state of knowledge.

The migration limits for Arsenic, Barium, and Nickel have been changed to reflect the latest information. In addition migration limits for Chromium VI and Organic Tin have been added.

The Technical Committee has also included a requirement for Bisphenol A (BPA) in soothers based on the most recent TDI from the 2015 EFSA Opinion and an A-Deviation from France. **A₂**

1 Scope

This European Standard specifies safety requirements relating to the materials, construction, performance, packaging and product information for soothers.

This European Standard is applicable to products that resemble or function as a soother. Some soothers may be marketed with other functions. This standard is applicable to these products (some examples are given in Annex C).

This European Standard does not apply to products designed for specialist clinical medical applications, e.g. those relating to Pierre-Robin Syndrome or premature babies (see Annex C).

The standard is not applicable to feeding teats. Safety requirements and test methods for feeding teats are included in all parts of EN 14350 [2], [3].

2 Normative references

The following documents, in whole or in part, are normatively referenced in this document and are indispensable for its application. For dated references, only the edition cited applies. For undated references, the latest edition of the referenced document (including any amendments) applies.

DIN 53160-1, *Determination of the colourfastness of articles for common use — Part 1: Test with artificial saliva*

EN 71-1, *Safety of toys — Part 1: Mechanical and physical properties*

EN 71-3, *Safety of toys — Part 3: Migration of certain elements*

EN 71-11:2005, *Safety of toys — Part 11: Organic chemical compounds — Methods of analysis*

EN 12868, *Child use and care articles — Methods for determining the release of N-Nitrosamines and N-Nitrosatable substances from elastomer or rubber teats and soothers*

EN 20105-A03, *Textiles — Tests for colour fastness — Part A03: Grey scale for assessing staining (ISO 105-A03)*

EN ISO 1302, *Geometrical Product Specifications (GPS) — Indication of surface texture in technical product documentation (ISO 1302)*

EN ISO 3696, *Water for analytical laboratory use — Specification and test methods (ISO 3696)*

ISO 188, *Rubber, vulcanized or thermoplastic — Accelerated ageing or heat resistance tests*

3 Terms and definitions

For the purposes of this document, the following terms and definitions apply.

3.1

soother

article which includes a teat and which is intended to satisfy the non-nutritive sucking need of children

Note 1 to entry: Soothers are also known as pacifiers or babies' dummies.

3.2

teat

part of the soother designed to be placed in the mouth

EN 1400:2013+A2:2018 (E)**3.3
shield**

structure positioned at the rear of the teat to reduce the likelihood of the soother being drawn entirely into the child's mouth

**3.4
ring**

structure positioned adjacent to or on the shield to facilitate handling of the soother

Note 1 to entry: The ring, knob or cover can be integral with the shield or plug or it can be a separate component that is attached to the shield or plug

Note 2 to entry: See Figure 1.

**3.5
knob**

structure positioned adjacent to or on the shield to facilitate gripping of the soother

Note 1 to entry: The ring, knob or cover can be integral with the shield or plug or it can be a separate component that is attached to the shield or plug.

Note 2 to entry: See Figure 2.

**3.6
plug**

device located within the neck of the teat that secures the teat to the shield

Note 1 to entry: See Figure 3.

**3.7
cover**

device that prevents open access to the plug

Note 1 to entry: The ring, knob or cover can be integral with the shield or plug or it can be a separate component that is attached to the shield or plug.

Note 2 to entry: See Figure 3.

**3.8
ventilation hole (see B.7)**

any shape of hole in the shield or teat protector that is large enough to allow sufficient passage of air to sustain life

Note 1 to entry: See also 8.4.1 and 11.3.1.

**3.9
teat protector**

device that can be attached to and detached from the soother to cover the teat

**3.10
outer packaging**

any packaging used for storage of the product by a retailer, not including the packaging intended for the consumer

3.11

major axis of the soother

major axis of the soother goes at right angles to the shield and through the centre of the teat, where the teat enters the shield

Note 1 to entry: See Figure 14.

3.12

major axis of the shield

major axis of the shield is parallel to the longest dimension of the shield and in the middle of the width

Note 1 to entry: See Figure 15.

4 Description of a soother

A soother, as shown in Figures 1, 2, 3 and 4, normally consists of:

- a teat,
- a shield, and
- either a ring or knob,

and can include:

- a plug, and
- a cover.

iTeh STANDARD PREVIEW
(standards.iteh.ai)

NOTE 1 Similar components are marked with the same number in Figures 1 to 4.

NOTE 2 Some or all of the components may be manufactured from the same material which may result in the components not being separately distinguishable.

NOTE 3 The ring, knob or cover can be integral with the shield or plug or it can be a separate component that is attached to the shield or plug.

EN 1400:2013+A2:2018 (E)

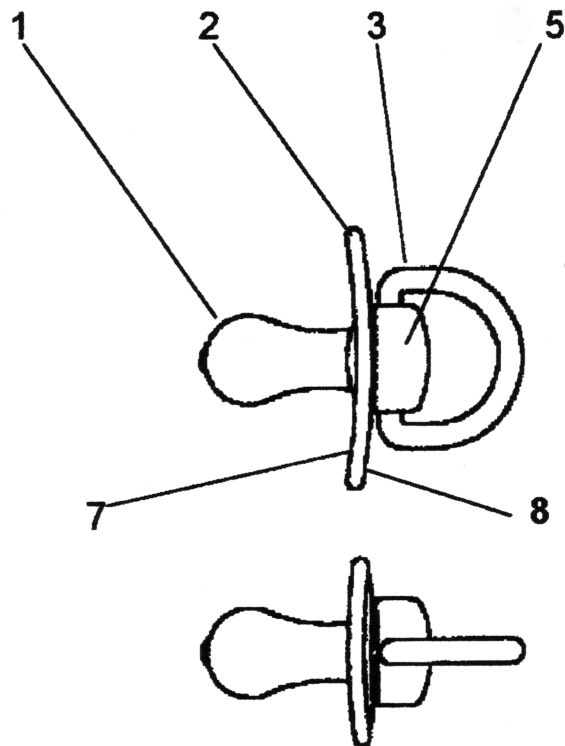
**Key**

- 1 teat
- 2 shield
- 3 ring
- 5 cover
- 7 sucking face of shield
- 8 rear face of shield

iTeh STANDARD PREVIEW
(standards.iteh.ai)

[SIST EN 1400:2013+A2:2018
https://standards.iteh.ai/catalog/standards/sist/10bffe4b-d0c8-43d6-a802-5db5642848c4/sist-en-1400-2013a2-2018](https://standards.iteh.ai/catalog/standards/sist/10bffe4b-d0c8-43d6-a802-5db5642848c4/sist-en-1400-2013a2-2018)

Figure 1 — Example of a soother with ring

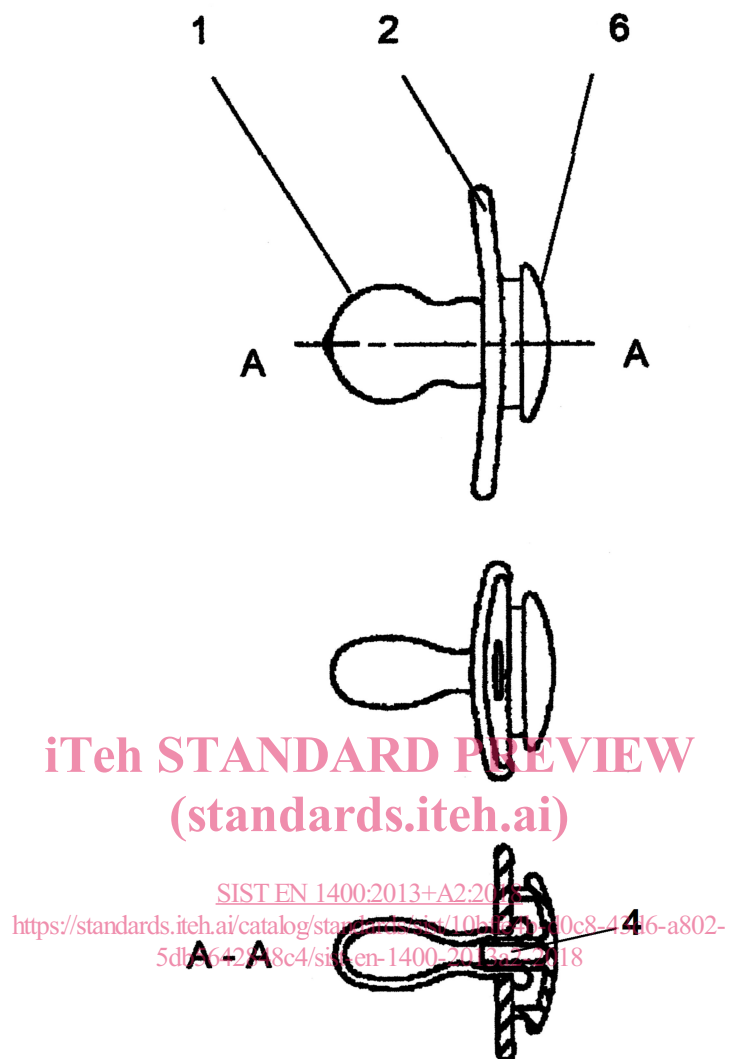
**Key**

- 1 teat
- 2 shield
- 4 plug
- 6 knob

Figure 2 — Example of a soother with knob

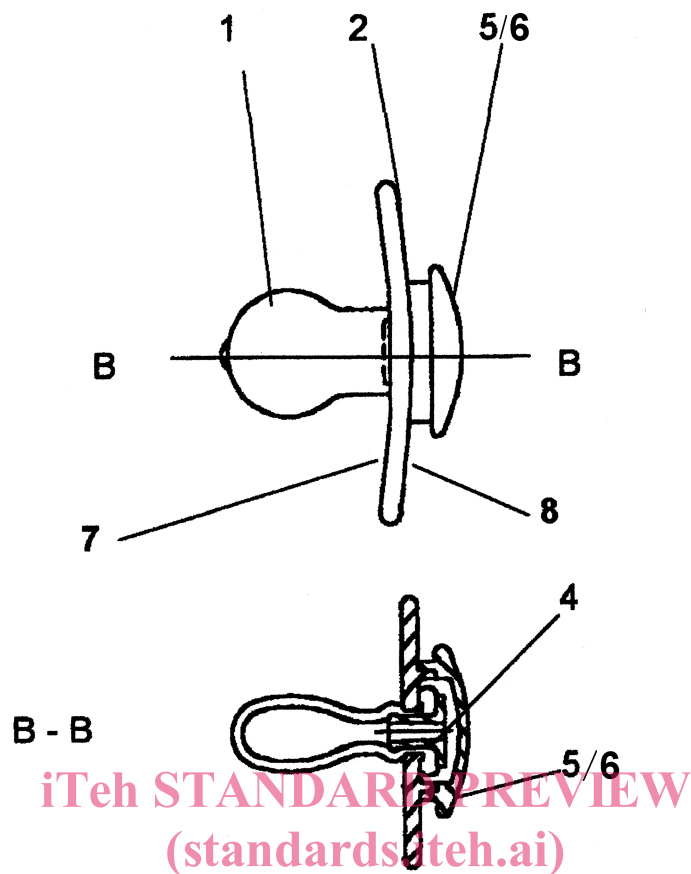
**Key**

- 1 teat
- 2 shield
- 4 plug
- 5 cover
- 6 knob
- 7 sucking face of shield
- 8 rear face of shield

SIST EN 1400:2013+A2:2018
<https://standards.iteh.ai/catalog/standards/sist/10bffe4b-d0c8-43d6-a802-5db5642848c4/sist-en-1400-2013a2-2018>

Figure 3 — Example of a soother with plug and cover

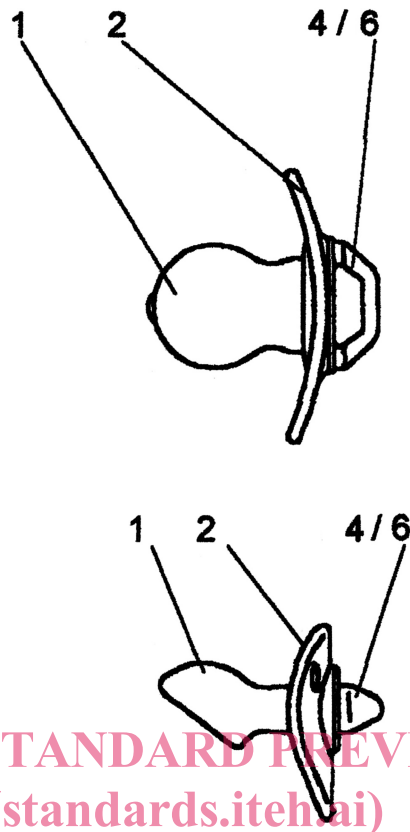

iTeh STANDARD PREVIEW
(standards.iteh.ai)

SIST EN 1400:2013+A2:2018

<https://standards.iteh.ai/catalog/standards/sist/10bffe4b-d0c8-43d6-a802-5db5642848c4/sist-en-1400-2013a2-2018>

Key

- 1 teat
- 2 shield
- 4 plug
- 6 knob

Figure 4 — Example of a soother with a combined plug and knob

5 Test equipment

5.1 Shield template

The shield template shall be made from Polyoxymethylene (POM), standard (natural, non pigmented, unfilled), E-modulus: 3000 MPa to 3300 MPa, hardness: 80 to 90 Shore D, Surface roughness: lower than Ra 2,2.

NOTE Extruded sheets of POM normally meet the surface roughness requirement.

The dimensions shall be as shown in Figure 5.

Dimensions in millimetres

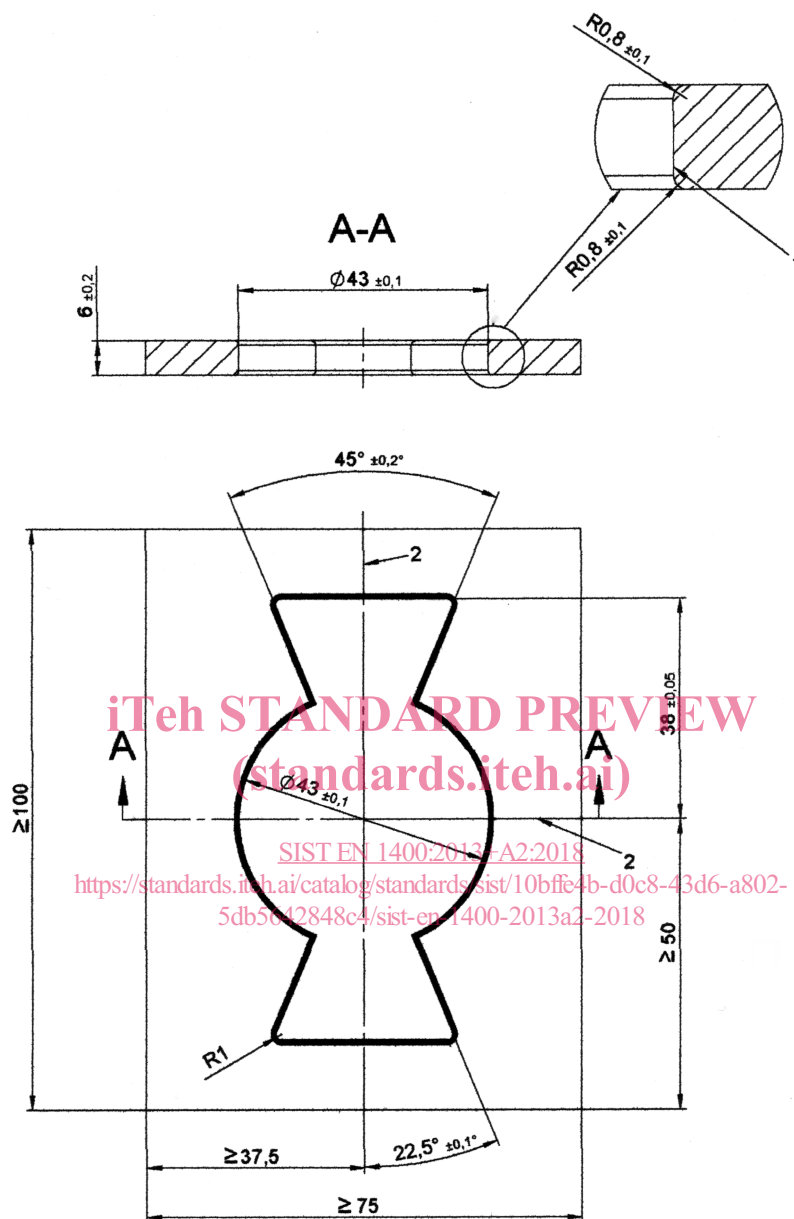
**Key**

- 1 enlarged part section A - A
- 2 permanent marks for major and minor axes

Figure 5 — Shield template**5.2 Test spheres**

Test spheres A, B, C and D, shall be made from stainless steel of diameters given in Table 1.

Table 1 — Test sphere diameters

Test sphere	Diameter mm
A	4,0 ^{+0,1} ₋₀
B	5,5 ⁺⁰ _{-0,1}
C	12 ^{+0,1} ₋₀
D	14 ^{+0,1} ₋₀

5.3 Indentor

The indentor is made from H13 high chrome tool steel or equivalent and hardened to a minimum of 50 Rockwell C and shall have dimensions as shown in Figure 6. All dimensions with a tolerance are machined as in EN ISO 1302 to $\sqrt{Ra \cdot 0,4}$. The larger diameter of the indentor has not been specified, as it should be of a size to fit into the equipment for applying the necessary force specified in the test methods.

Dimensions in millimetres

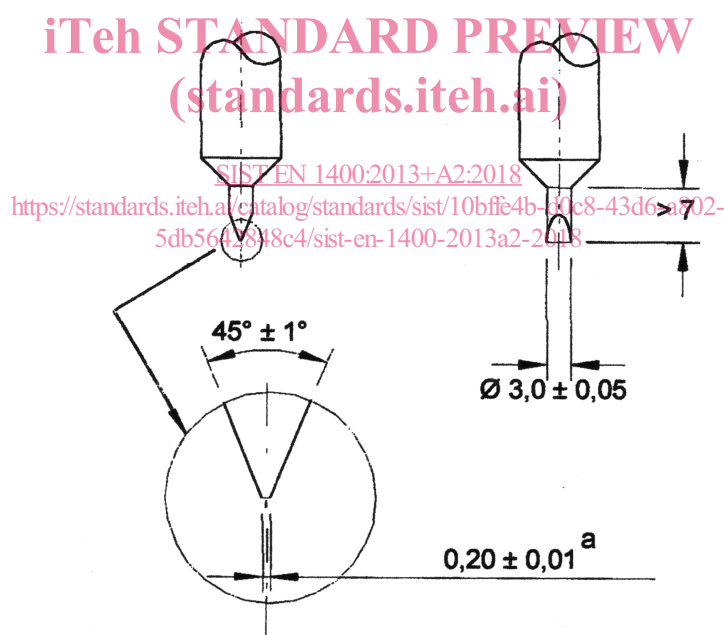

Key

a This face is flat and has dimensions of (3,0 x 0,20) mm.

Figure 6 — Indentor

5.4 Cutting board

The cutting board is made from a polymeric material of (70 ± 5) Shore D hardness with a stop made from any suitable material to the dimensions as shown in Figure 7. All dimensions shall have a tolerance