Aeronavtika - LOTAR - Dolgoročno arhiviranje in pridobivanje digitalne tehnične dokumentacije o izdelkih, kot so podatki o 3D, CAD in PDM - 125. del: Eksplicitna struktura sestavljanja CAD z informacijami o grafičnem izdelku in proizvodnji (PMI)

Aerospace series - LOTAR - LOng Term Archiving and Retrieval of digital technical product documentation such as 3D, CAD and PDM data - Part 125: Explicit CAD assembly structure with Graphic Product and Manufacturing Information (PMI)

Luft- und Raumfahrt - LOTAR - Langzeit-Archivierung und - Bereitstellung digitaler technischer Produktdokumentationen, wie zum Beispiel von 3D, CAD und PDM-Daten - Teil 125: Eindeutige CAD-Baugruppenstruktur mit grafischen Produkt und Fertigungsinformationen (PMI)

Série aérospatiale - LOTAR - Archivage long terme et récupération des données techniques produits numériques telles que CAO, 3D et PDM - Partie 125 : Structure d'assemblage CAO explicite avec données graphiques de produit et de fabrication (PMI)

Ta slovenski standard je istoveten z: EN 9300-125:2023

ICS:

01.110	Tehnična dokumentacija za izdelke	Technical product documentation
35.240.30	Uporabniške rešitve IT v informatiki, dokumentiranju in založništvu	IT applications in information, documentation and publishing
49.020	Letala in vesoljska vozila na splošno	Aircraft and space vehicles in general

SIST EN 9300-125:2024**en,fr,de**

EUROPEAN STANDARD

EN 9300-125

NORME EUROPÉENNE

EUROPÄISCHE NORM

November 2023

ICS 01.110

English Version

Aerospace series - LOTAR - Long Term Archiving and Retrieval of digital technical product documentation such as 3D, CAD and PDM data - Part 125: Explicit CAD assembly structure with Graphic Product and Manufacturing Information (PMI)

Série aérospatiale - LOTAR - Archivage long terme et récupération des données techniques produits numériques telles que CAO, 3D et PDM - Partie 125 : Structure d'assemblage CAO explicite avec données graphiques de produit et de fabrication (PMI)

Luft- und Raumfahrt - LOTAR - Langzeit-Archivierung und - Bereitstellung digitaler technischer Produktdokumentationen, wie zum Beispiel von 3D, CAD und PDM-Daten - Teil 125: Eindeutige CAD-Baugruppenstruktur mit grafischen Produkt und Fertigungsinformationen (PMI)

This European Standard was approved by CEN on 22 December 2019.

CEN members are bound to comply with the CEN/CENELEC Internal Regulations which stipulate the conditions for giving this European Standard the status of a national standard without any alteration. Up-to-date lists and bibliographical references concerning such national standards may be obtained on application to the CEN-CENELEC Management Centre or to any CEN member.

This European Standard exists in three official versions (English, French, German). A version in any other language made by translation under the responsibility of a CEN member into its own language and notified to the CEN-CENELEC Management Centre has the same status as the official versions.

CEN members are the national standards bodies of Austria, Belgium, Bulgaria, Croatia, Cyprus, Czech Republic, Denmark, Estonia, Finland, France, Germany, Greece, Hungary, Iceland, Ireland, Italy, Latvia, Lithuania, Luxembourg, Malta, Netherlands, Norway, Poland, Portugal, Republic of North Macedonia, Romania, Serbia, Slovakia, Slovenia, Spain, Sweden, Switzerland, Türkiye and United Kingdom.



EUROPEAN COMMITTEE FOR STANDARDIZATION
COMITÉ EUROPÉEN DE NORMALISATION
EUROPÄISCHES KOMITEE FÜR NORMUNG

CEN-CENELEC Management Centre: Rue de la Science 23, B-1040 Brussels

Contents

Page

European foreword	3
1 Scope.....	4
1.1 General.....	4
1.2 Out of scope.....	4
2 Normative references.....	4
3 Terms, definitions and abbreviations	5
4 Applicability.....	5
5 Business specifications for the long term archiving and retrieval of the explicit CAD assembly structure with PMI.....	5
5.1 Use cases	5
5.1.1 UC1: one file with assembly structure, geometry and PMI	5
5.1.2 UC2: Assembly Structure with PMI stored in one file separate from the Geometry.....	6
5.1.3 UC3: Nested structure and assembly file with PMI in the structure file	6
5.1.4 UC4: Nested structure and assembly files with PMI side-car file.	6
6 Essential Information for explicit CAD assembly structure with PMI	7
6.1 Associativity between PMI and Geometric Shape Representation	7
6.1.1 Assembly files with PMI with references to sub-assembly and shape element of part geometry	8
6.2 Saved View.....	8
7 Definition of Core Model for an explicit CAD assembly structure with PMI	9
8 Verification rules of an explicit CAD assembly structure with PMI.....	10
8.1 General.....	10
8.2 Level of Verification	11
9 Validation properties	11
9.1 General.....	11
9.2 Levels of Validation	12
9.3 Comparison of the PMI Validation Properties (PMIVP)	13
9.4 Results of the Validation	13
9.4.1 At the ingest process (qualify)	13
9.4.2 At the retrieval process (comparison)	14
9.4.3 Status information.....	14
9.4.4 Validation reports.....	14
Annex A (normative) Ingestion scenarios.....	15
A.1 Ingestion scenario 1: One AIP with assembly structure, geometry and PMI.....	16
A.2 Ingestion scenario 2: one AIP for the assembly with PMI	18
A.3 Scenario 3: one or more AIPs for the assembly with PMI.....	20
A.4 Scenario 4: One AIP for the assembly PMI	22
Bibliography.....	24

European foreword

This document (EN 9300-125:2023) has been prepared by the Aerospace and Defence Industries Association of Europe — Standardization (ASD-STAN).

After enquiries and votes carried out in accordance with the rules of this Association, this document has received the approval of the National Associations and the Official Services of the member countries of ASD-STAN, prior to its presentation to CEN.

This European Standard shall be given the status of a national standard, either by publication of an identical text or by endorsement, at the latest by May 2024, and conflicting national standards shall be withdrawn at the latest by May 2024.

Attention is drawn to the possibility that some of the elements of this document may be the subject of patent rights. CEN shall not be held responsible for identifying any or all such patent rights.

According to the CEN-CENELEC Internal Regulations, the national standards organizations of the following countries are bound to implement this European Standard: Austria, Belgium, Bulgaria, Croatia, Cyprus, Czech Republic, Denmark, Estonia, Finland, Republic of North Macedonia, France, Germany, Greece, Hungary, Iceland, Ireland, Italy, Latvia, Lithuania, Luxembourg, Malta, Netherlands, Norway, Poland, Portugal, Romania, Serbia, Slovakia, Slovenia, Spain, Sweden, Switzerland, Turkey and the United Kingdom.

Any feedback and questions on this document should be directed to the users' national standards body. A complete listing of these bodies can be found on the CEN website.

(<https://standards.iteh.ai>)
Document Preview

[SIST EN 9300-125:2024](https://standards.iteh.ai/catalog/standards/sist/f0cd9ac1-8ea2-47a7-8bd6-cc244becde53/sist-en-9300-125-2024)

<https://standards.iteh.ai/catalog/standards/sist/f0cd9ac1-8ea2-47a7-8bd6-cc244becde53/sist-en-9300-125-2024>

EN 9300-125:2023 (E)

1 Scope

1.1 General

This document specifies the requirements for the long term digital preservation of the presentation of Product and Manufacturing Information (PMI) with their possible links to the 3D explicit shape and geometry of CAD assembly structure. The goal is to preserve this 3D information, without loss, with respect to the geometry produced by the original CAD system, following the principles laid down in EN 9300-003 'Fundamentals and Concepts'.

This will allow the retrieval of the assembly structure including the placement information.

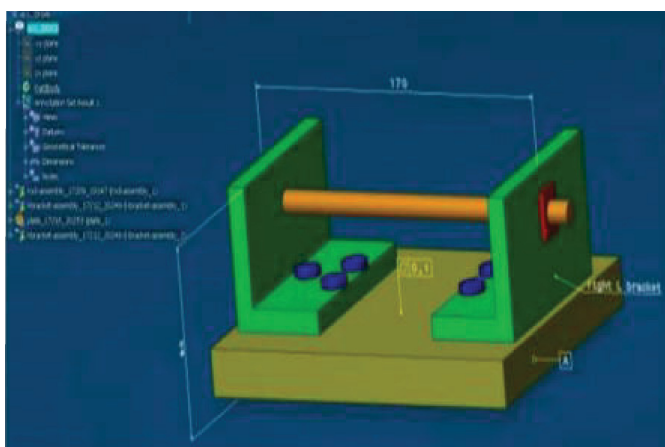

Figure 1 — Assembly structure and geometric assembly model with PMI

This document extends EN 9300-115 "Explicit CAD Assembly Structure" by including assembly level PMI.

PMI for the assembly structure can be recorded in the same file as the geometry, can be in a nested assembly structure or the PMI will be contained in its own separate file (Side-Car).

The PMI elements shall be presented on the graphic level only (i.e. polyline, tessellated).^{3/sist-en-9300-125-2024}

1.2 Out of scope

The following is outside the scope:

- the archiving of assembly Form Features;
- semantic PMI representation is out of scope for this document;
- the geometry specified at assembly level is out of scope for this edition.

2 Normative references

The following documents are referred to in the text in such a way that some or all of their content constitutes requirements of this document. For dated references, only the edition cited applies. For undated references, the latest edition of the referenced document (including any amendments) applies.

EN 9300 (all parts), *Aerospace series — LOTAR — LOng Term Archiving and Retrieval of digital technical product documentation such as 3D, CAD and PDM data*

ISO 10303-21, *Industrial automation systems and integration — Product data representation and exchange — Part 21: Implementation methods: Clear text encoding of the exchange structure*

ISO 10303-242, *Industrial automation systems and integration — Product data representation and exchange — Part 242: Application protocol: Managed model-based 3D engineering*

ISO 10303-519, *Industrial automation systems and integration — Product data representation and exchange — Part 519: Application interpreted construct: Geometric tolerances*

ISO 16792, *Technical product documentation — Digital product definition data practices*

Further applicable documents

CAx-IF Recommended Practices for the Representation and Presentation of Product & Manufacturing Information (PMI) (AP242)

CAx-IF Recommended Practices for User Defined Attributes (UDA)

3 Terms, definitions and abbreviations

For the purposes of this document, the terms, definitions and abbreviations given in EN 9300-007 and the following apply.

ISO and IEC maintain terminological databases for use in standardization at the following addresses:

- ISO Online browsing platform: available at <https://www.iso.org/obp>
- IEC Electropedia: available at <https://www.electropedia.org/>

3.1

Side Car

separate file to retain the PMI definition; this file is referenced by the assembly file

4 Applicability

Refer to applicability of EN 9300-001 “Structure”, Clause 4.

5 Business specifications for the long term archiving and retrieval of the explicit CAD assembly structure with PMI

5.1 Use cases

The following clauses record the potential use cases for the archiving of an explicit CAD assembly structure with PMI. “Appendix A Ingestion scenarios (informative)” identifies the main archiving scenarios corresponding to these four use cases.

5.1.1 UC1: one file with assembly structure, geometry and PMI

This Use Case represents a scenario with a single file containing the assembly structure, geometry and PMI.

EN 9300-125:2023 (E)

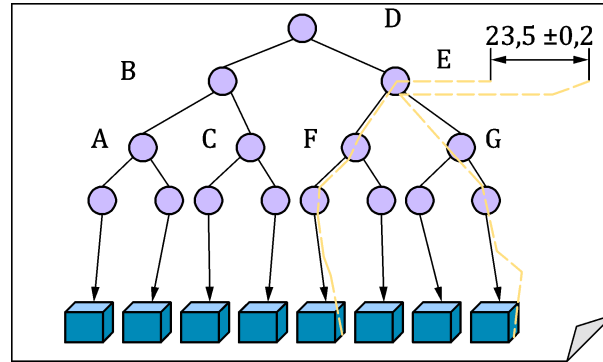

Figure 2 — One file with assembly structure, geometry and PMI

5.1.2 UC2: Assembly Structure with PMI stored in one file separate from the Geometry

This Use Case represents a scenario with a single file containing the assembly structure and PMI separate from the geometry. The Geometry will be stored in separate file(s).

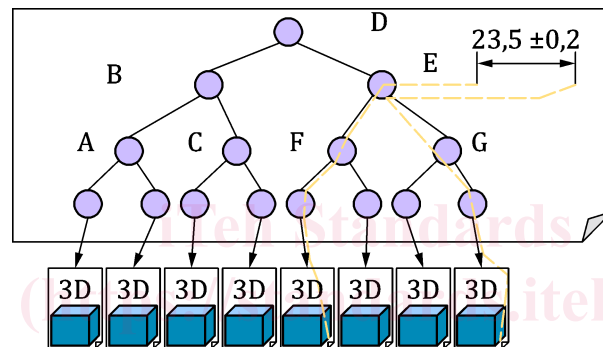

Figure 3 — Separate file for Assembly Structure and PMI

5.1.3 UC3: Nested structure and assembly file with PMI in the structure file

<https://standards.iteh.ai/catalog/standards/sist/f0cd9ac1-8ea2-47a7-8bd6-cc244becde53/sist-en-9300-125-2024>

This Use Case represents a scenario with nested files with PMI contained in the assembly structure. The PMI is contained in the file representing the node that is defining the context of the PMI.

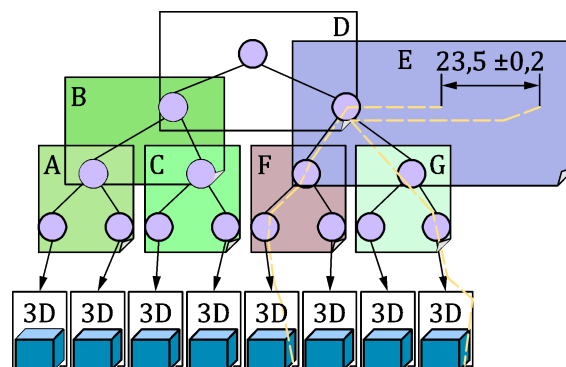

Figure 4 — Nested structure and assembly file with PMI in the structure file

5.1.4 UC4: Nested structure and assembly files with PMI side-car file.

This Use Case represents a scenario where the PMI is contained in a separate Side-car file.

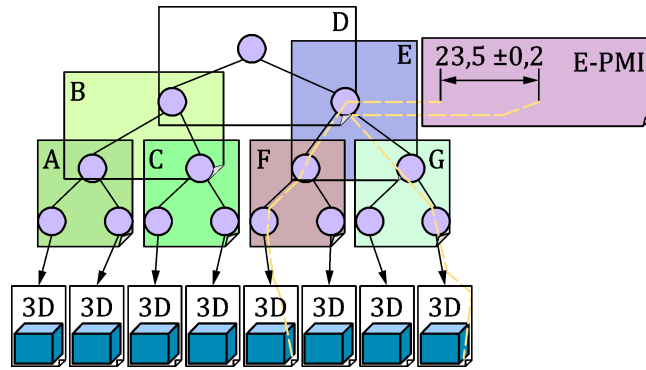

Figure 5 — Nested structure and assembly files with PMI side-car file

6 Essential Information for explicit CAD assembly structure with PMI

The following list describes the essential information for a CAD assembly with PMI structure. The essential information are captured, verified and validated through the core model and the rules. The core model is described in the clause “7 Definition of Core Model for an explicit CAD assembly structure” and the rules are described in the clauses “8 Verification rules of CAD explicit assembly with PMI structure” and “9 Validation rules of an explicit CAD assembly with PMI structure”. Bring in Part 120 essential information attributes.

6.1 Associativity between PMI and Geometric Shape Representation

The same technique to associate between 3D PMI and the related Shape Element at the part level that maintains the relationship created by the user when they attach PMI to a geometric model is also used at the assembly level.

Reference EN 9300-120e1 Clause 6 for Essential Information with the following additions

At the part level PMI referencing shape element of part geometry. (Ref. Figure 6: Illustration of PMI and the Part Level).

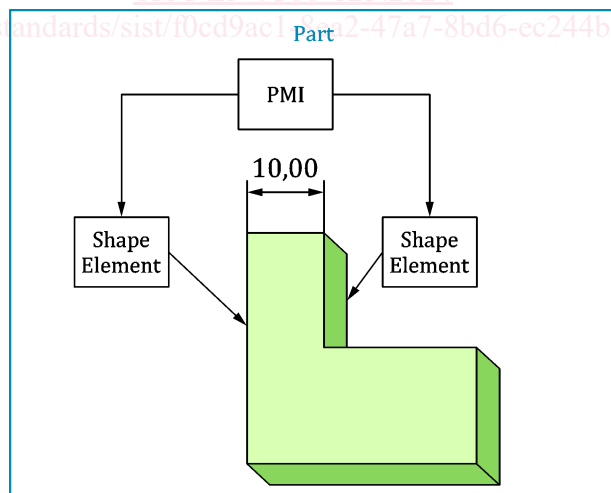

Figure 6 — Illustration of PMI at the Part Level

EN 9300-125:2023 (E)

6.1.1 Assembly files with PMI with references to sub-assembly and shape element of part geometry

A path should be specified for all assemblies and part occurrences applicable to each shape element as required. (ref Figure 7: Illustration of PMI at the Assembly Level).

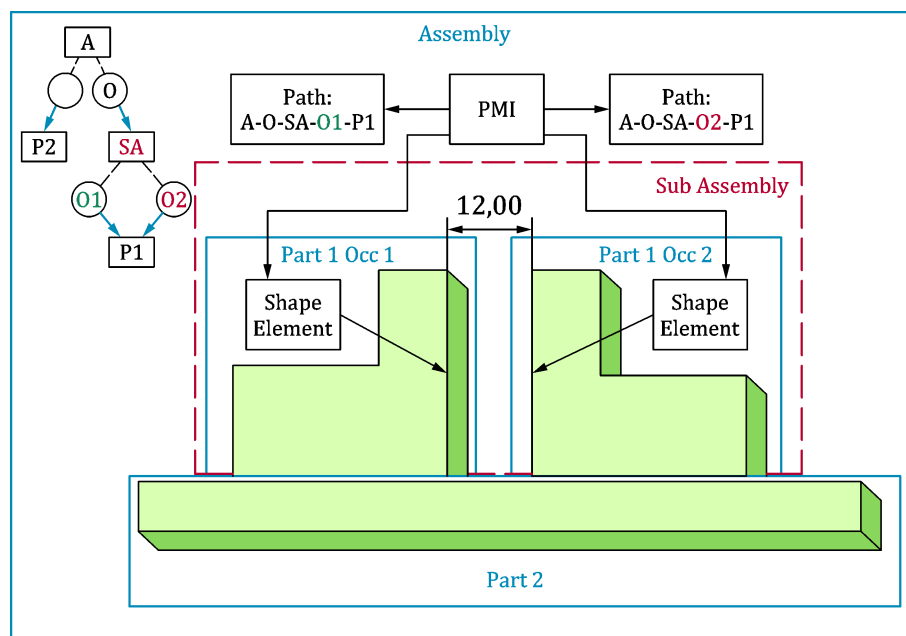

Figure 7 — Illustration of PMI at the Assembly Level

6.2 Saved View

The saved view complies with the following definition taken from ISO 16792.

Saved views

Saved views of a design model may be specified to facilitate presentation of the model and its annotation. A saved view shall have an identifier, be retrievable on demand, contain a model coordinate system that denotes the direction of the view relative to the model and may contain one or more of the annotation plane(s), a selected set of annotation, or a selected set of geometry.

NOTE The term “saved view” will be used in this Part. The following list of equal terms might help in technical discussions:

- STEP Saved View;
- CATIA V5 Capture;
- NX Work view;
- Pro/Engineer/Creo Model Display/Combination State;
- Autodesk View face.

At assembly level, the saved view is stored in the file of the assembly PMI. So, the saved view is directly linked to the annotation plane, the clipping plane or the assembly PMI. But the selected set of geometry,