



**SLOVENSKI STANDARD**  
**oSIST prEN ISO 8847:2020**  
**01-februar-2020**

---

**Mala plovila - Krmilni mehanizem - Sistemi s kabli preko škripčevja (ISO/DIS 8847:2019)**

Small craft - Steering gear - Cable over pulley systems (ISO/DIS 8847:2019)

Kleine Wasserfahrzeuge - Steuerungssystem - Kabel- und Seilzugsteuerung (ISO/DIS 8847:2019)

**iTeh STANDARD PREVIEW**  
**(standards.iteh.ai)**

Petits navires - Appareils à gouverner - Systèmes à drosses et réas (ISO/DIS 8847:2019)

**Ta slovenski standard je istoveten z: prEN ISO 8847**  
<https://standards.iteh.ai/catalog/standards/sist/53172fe-4e52-85d4-6fd8f5bd74ea/ksist-pr-en-iso-8847-2020>

---

**ICS:**

47.020.70	Navigacijska in krmilna oprema	Navigation and control equipment
47.080	Čolni	Small craft

**oSIST prEN ISO 8847:2020**

**en,fr,de**

**iTeh STANDARD PREVIEW**  
**(standards.iteh.ai)**

[kSIST FprEN ISO 8847:2020](#)

<https://standards.iteh.ai/catalog/standards/sist/2b9f3363-d3fe-4e52-85d4-6fd8f5bd74ea/ksist-fpren-iso-8847-2020>

# DRAFT INTERNATIONAL STANDARD

## ISO/DIS 8847

ISO/TC 188

Secretariat: SIS

Voting begins on:  
2019-12-06Voting terminates on:  
2020-02-28

---

---

## Small craft — Steering gear — Cable over pulley systems

*Petits navires — Appareils à gouverner — Systèmes à drosses et réas*

ICS: 47.080

### iTeh STANDARD PREVIEW (standards.iteh.ai)

[kSIST FprEN ISO 8847:2020](https://standards.iteh.ai/catalog/standards/sist/2b9f3363-d3fe-4e52-85d4-6fd8f5bd74ea/ksist-fpren-iso-8847-2020)<https://standards.iteh.ai/catalog/standards/sist/2b9f3363-d3fe-4e52-85d4-6fd8f5bd74ea/ksist-fpren-iso-8847-2020>

THIS DOCUMENT IS A DRAFT CIRCULATED FOR COMMENT AND APPROVAL. IT IS THEREFORE SUBJECT TO CHANGE AND MAY NOT BE REFERRED TO AS AN INTERNATIONAL STANDARD UNTIL PUBLISHED AS SUCH.

IN ADDITION TO THEIR EVALUATION AS BEING ACCEPTABLE FOR INDUSTRIAL, TECHNOLOGICAL, COMMERCIAL AND USER PURPOSES, DRAFT INTERNATIONAL STANDARDS MAY ON OCCASION HAVE TO BE CONSIDERED IN THE LIGHT OF THEIR POTENTIAL TO BECOME STANDARDS TO WHICH REFERENCE MAY BE MADE IN NATIONAL REGULATIONS.

RECIPIENTS OF THIS DRAFT ARE INVITED TO SUBMIT, WITH THEIR COMMENTS, NOTIFICATION OF ANY RELEVANT PATENT RIGHTS OF WHICH THEY ARE AWARE AND TO PROVIDE SUPPORTING DOCUMENTATION.

This document is circulated as received from the committee secretariat.

**ISO/CEN PARALLEL PROCESSING**



Reference number  
ISO/DIS 8847:2019(E)

© ISO 2019

## iTeh STANDARD PREVIEW (standards.iteh.ai)

[kSIST FprEN ISO 8847:2020  
https://standards.iteh.ai/catalog/standards/sist/2b9f3363-d3fe-4e52-85d4-6fd8f5bd74ea/ksist-fpren-iso-8847-2020](https://standards.iteh.ai/catalog/standards/sist/2b9f3363-d3fe-4e52-85d4-6fd8f5bd74ea/ksist-fpren-iso-8847-2020)



### **COPYRIGHT PROTECTED DOCUMENT**

© ISO 2019

All rights reserved. Unless otherwise specified, or required in the context of its implementation, no part of this publication may be reproduced or utilized otherwise in any form or by any means, electronic or mechanical, including photocopying, or posting on the internet or an intranet, without prior written permission. Permission can be requested from either ISO at the address below or ISO's member body in the country of the requester.

ISO copyright office  
CP 401 • Ch. de Blandonnet 8  
CH-1214 Vernier, Geneva  
Phone: +41 22 749 01 11  
Fax: +41 22 749 09 47  
Email: [copyright@iso.org](mailto:copyright@iso.org)  
Website: [www.iso.org](http://www.iso.org)

Published in Switzerland

# Contents

	Page
Foreword .....	iv
<b>1 Scope .....</b>	<b>1</b>
<b>2 Normative references .....</b>	<b>1</b>
<b>3 Terms and definitions .....</b>	<b>1</b>
<b>4 General Requirements .....</b>	<b>4</b>
<b>5 Construction requirements .....</b>	<b>4</b>
<b>6 Installation .....</b>	<b>8</b>
<b>7 Testing Requirements .....</b>	<b>14</b>
<b>8 Owner's manual .....</b>	<b>17</b>
<b>9 Instruction manual .....</b>	<b>17</b>
<b>Annex A (informative) Recommended procedures for conducting cable over pulley strength tests required in <a href="#">Section 7.1</a> for outboard engine applications .....</b>	<b>19</b>
<b>Annex ZA (informative) Relationship between this European Standard and the essential requirements of Directive 2013/53/EU aimed to be covered .....</b>	<b>22</b>

## iTeh STANDARD PREVIEW (standards.iteh.ai)

[kSIST FprEN ISO 8847:2020](https://standards.iteh.ai/catalog/standards/sist/2b9f3363-d3fe-4e52-85d4-6fd8f5bd74ea/ksist-fpren-iso-8847-2020)  
<https://standards.iteh.ai/catalog/standards/sist/2b9f3363-d3fe-4e52-85d4-6fd8f5bd74ea/ksist-fpren-iso-8847-2020>

## ISO/DIS 8847:2019(E)

## Foreword

ISO (the International Organization for Standardization) is a worldwide federation of national standards bodies (ISO member bodies). The work of preparing International Standards is normally carried out through ISO technical committees. Each member body interested in a subject for which a technical committee has been established has the right to be represented on that committee. International organizations, governmental and non-governmental, in liaison with ISO, also take part in the work. ISO collaborates closely with the International Electrotechnical Commission (IEC) on all matters of electrotechnical standardization.

The procedures used to develop this document and those intended for its further maintenance are described in the ISO/IEC Directives, Part 1. In particular the different approval criteria needed for the different types of ISO documents should be noted. This document was drafted in accordance with the editorial rules of the ISO/IEC Directives, Part 2 (see [www.iso.org/directives](http://www.iso.org/directives)).

Attention is drawn to the possibility that some of the elements of this document may be the subject of patent rights. ISO shall not be held responsible for identifying any or all such patent rights. Details of any patent rights identified during the development of the document will be in the Introduction and/or on the ISO list of patent declarations received (see [www.iso.org/patents](http://www.iso.org/patents)).

Any trade name used in this document is information given for the convenience of users and does not constitute an endorsement.

For an explanation on the voluntary nature of standards, the meaning of ISO specific terms and expressions related to conformity assessment, as well as information about ISO's adherence to the World Trade Organization (WTO) principles in the Technical Barriers to Trade (TBT) see the following URL: [www.iso.org/iso/foreword.html](http://www.iso.org/iso/foreword.html). (standards.iteh.ai)

This document was prepared by Technical Committee ISO/TC 188 *Small craft*.

This fourth edition cancels and replaces the third edition (ISO 8847:2017), which has been technically revised.

The main changes compared to the previous edition are as follows:

- Update of the definitions;
- Update of requirements to meet current industry practice;
- Addition of powered craft with outboard engines up to and including 37 kW total horsepower.

Any feedback or questions on this document should be directed to the user's national standards body. A complete listing of these bodies can be found at [www.iso.org/members.html](http://www.iso.org/members.html)

# Small craft — Steering gear — Cable over pulley systems

## 1 Scope

This document specifies the requirements for the design, construction, installation and testing of cable over pulley steering systems on sailing craft of hull lengths up to 24 m with or without an auxiliary engine and powered craft of hull lengths up to 24 m with outboard engines up to and including 37 kW total horsepower.

This document specifies the requirements for the design and construction of all components of a steering system from the helm to rudder connection point or connection to the outboard engine. It applies to cable over pulley steering systems, whether for pedestal or bulkhead types.

This document does not address emergency means of steering the craft.

## 2 Normative references

The following documents are referred to in the text in such a way that some or all of their content constitutes requirements of this document. For dated references, only the edition cited applies. For undated references, the latest edition of the referenced document (including any amendments) applies.

ISO 2408:2017, *Steel wire ropes — Requirements*

## 3 Terms and definitions

For the purposes of this document, the following terms and definitions apply.

ISO and IEC maintain terminological databases for use in standardization at the following addresses:

- IEC Electropedia: available at <http://www.electropedia.org/>
- ISO Online browsing platform: available at <https://www.iso.org/obp>

### 3.1

#### **accessible**

capable of being reached for operation, inspection or maintenance without removal of permanent structure of the craft

### 3.2

#### **cable**

flexible mechanical means of transmitting tension forces from one location to another

Note 1 to entry: This cable could be metallic or non-metallic

### 3.3

#### **cable drum**

circular feature of the steering helm over which the steering cable is routed to provide the required cable travel

### 3.4

#### **cable over pulley steering system**

a steering system in which rotation of the steering wheel transmits movement of the rudder blade steering arm quadrant fastened to the rudder shaft or outboard steering arm by mechanical means including flexible cable over pulleys mounted to the structure of the craft

## ISO/DIS 8847:2019(E)

## 3.5

**cable load**

Force applied to the cable providing the necessary torque to move the rudder through the rudder shaft/steering arm or outboard engine while the craft is underway

## 3.6

**cable in conduit steering systems**

steering system in which rotation of the steering wheel transmits movement of the rudder blade steering arm quadrant fastened to the rudder shaft or outboard steering arm by mechanical means including flexible cable and conduits with or without use of pulleys

## 3.7

**fairlead**

ring, eye or loop that guides a cable in the desired direction. A pulley may also perform the function of a fairlead

## 3.8

**swivel pulley**

pulley whose attachment feature is designed to allow the pulley to rotate freely about the swivel centreline. See [Figure 1](#)

## 3.9

**fixed strap pulley**

pulley whose attachment is designed for minimum if any rotation of the pulley assembly about the fixed strap axis. See [Figure 1](#)

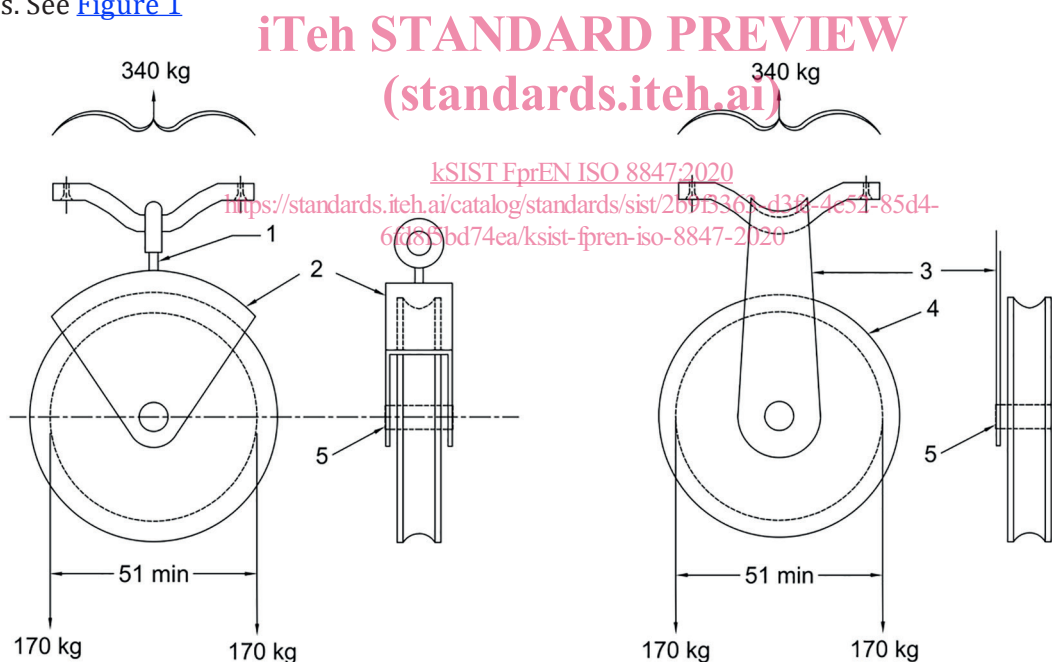
**Key**

- 1 swivel
- 2 cheek strap
- 3 fixed strap
- 4 sheave

**Figure 1 — Pulleys for outboard cable over pulley systems**

## 3.10

**steering helm**

operator input device for the control of steering



**3.11****helm station**

location from which steering, propulsion and thrust can be controlled

**3.12****minimum retained system performance**

System capability after test(s) such that at least 90% of the rudder blade steering arm quadrant or outboard engine steering arm travel normally available each side of the mid-position may be attained by exertion of no more than 27 Nm of torque at the helm through the steering wheel.

Note 1 to entry: These limits are not intended to define a condition under which a craft can or cannot be safely operated but are intended to provide quantitative limits for design and testing purposes.

**3.13****steering arm component fixed to the rudder shaft with at least one groove for the cable concentric to the shaft centre.**

Note 1 to entry: The steering arm may be a wheel quadrant (see [Figure 2a](#)), a quadrant (see [Figure 2b](#)) or a tiller quadrant (see [Figure 2c](#)).



**Figure 2 — Examples of steering arm types**

**3.14****steering system**

assembly including all components necessary to transmit remote manual effort to the rudder blade steering arm quadrant or outboard engine steering arm

**3.15****total steering loss**

complete loss of the ability to steer the craft from the helm position by application of manual effort to the steering wheel

**3.16****steering wheel**

mechanical means for applying manual steering effort to the helm, normally a circular configuration with a continuous loop at the distal end of support spokes with the helm connected at the rotational axis

**3.17****steering wheel diameter**

the diameter of the circle formed by the outermost sections of the steering wheel, See [Figure 3](#)

## ISO/DIS 8847:2019(E)

### 3.18

#### steering wheel dish

the distance between the two parallel planes formed by the aft rim surface and the forward hub surface of a steering wheel, see [Figure 3](#)

### 3.19

#### craft

##### small craft

recreational craft, and other watercraft using similar equipment, of up to 24 m length of hull ( $L_H$ )

## 4 General Requirements

**4.1** To ensure the proper operation of a steering system, all components shall be fastened securely to the structure of the craft, reinforced where necessary, especially at the helm bulkhead/pedestal mounting and at pulleys.

**4.2** The steering arm connection to the rudder shaft shall also be capable of transmitting the required steering torque to the rudder.

**4.3** Cable over pulley steering systems designed to meet the requirements of this standard shall not be used to steer craft having engine(s) in excess of 37 kW total power.

**4.4** All threaded fasteners whose integrity affects safe operation of the steering system such that separation or loss of the fasteners may cause sudden loss of steering without warning shall be provided with a locking means.

**4.4.1** Threaded fasteners that may be expected to be disturbed by installation or adjustment procedures, shall be referenced by instructions for correct assembly and –

**4.4.2** Shall be locked by a device whose presence is determined by visual inspection or by feel following assembly, or

**4.4.3** Shall incorporate an integral locking means, provided the fastener cannot be omitted or substituted without making the steering system inoperable.

**NOTE** Self-locking nuts with plastic inserts that create mechanical plastic interference meet the above stated requirements.

**4.4.4** Loose lock washers, distorted thread nuts or separately applied adhesives are prohibited.

**4.4.5** Plain threaded jam nuts may be used to permit adjustments and shall be designed so that total separation of parts or other complete loss of steering will not occur should they loosen.

## 5 Construction requirements

**5.1** Steering stops for the outboard engine shall permit at least 30° of angular movement either side of centre. Stops for the rudder blade steering arm quadrant shall be set by the hull design engineer.

**5.2** When used with an outboard engine, the cable over pulley steering system attachment to the engine shall be designed so that with any combination of engine turn and tilt, there will be no damaging interference between the engine, its accessories, the steering system and the craft.

**5.3** Installation instructions for the steering helm shall include recommendations for the maximum diameter and deepest dish wheel that can be used with the helm. In addition, the maximum diameter and

deepest dish wheel information shall be permanently marked so as to be visible with the helm installed and the wheel removed. See [Figure 3](#)

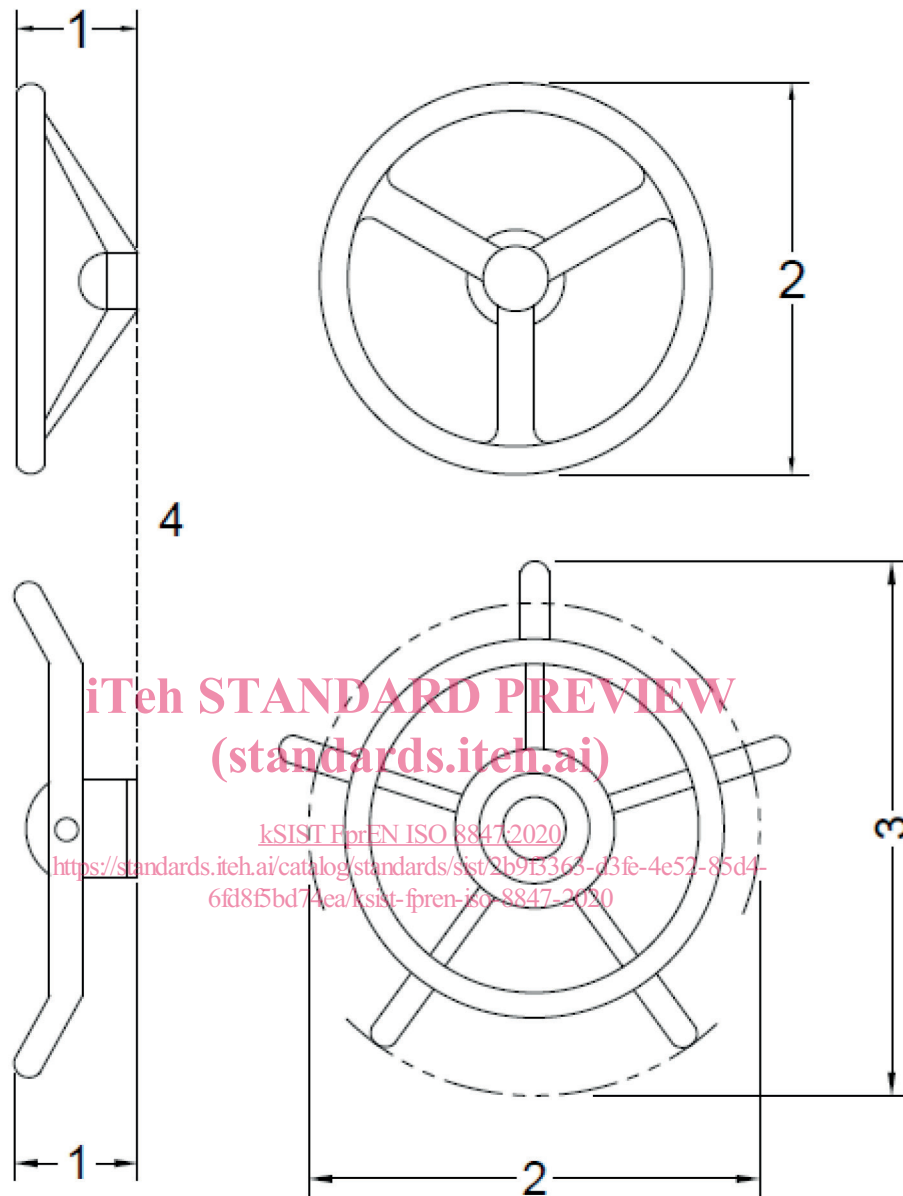

#### Key

- 1 dish
- 2 diameter
- 3 actual diameter
- 4 wheel level line

**Figure 3 — Steering wheel terms**

**5.3.1** When equipped with the largest diameter and deepest dish steering wheel for which the helm is rated, all steering components shall be of sufficient strength to successfully pass the Testing Requirements of [Section 7](#).

**5.4** The radius of the steering arm and cable diameter shall be chosen such that the cable load is less than 25 % of the cable breaking strength. The steering arm radius shall be concentric with the rudder