



SLOVENSKI STANDARD
oSIST prEN ISO 10592:2020
01-februar-2020

Mala plovila - Hidravlični sistemi krmiljenja (ISO/DIS 10592:2019)

Small craft - Hydraulic steering systems (ISO/DIS 10592:2019)

Kleine Wasserfahrzeuge - Hydraulische Steueranlagen (ISO/DIS 10592:2019)

Petits navires - Appareils à gouverner hydrauliques (ISO/DIS 10592:2019)

Ta slovenski standard je istoveten z: prEN ISO 10592

[ksIST FprEN ISO 10592:2021](https://standards.iteh.ai/catalog/standards/sist/86172dc9-ebb5-4e02-8670-f4869dab6d16/ksist-fpren-iso-10592-2021)

<https://standards.iteh.ai/catalog/standards/sist/86172dc9-ebb5-4e02-8670-f4869dab6d16/ksist-fpren-iso-10592-2021>

ICS:

47.020.70	Navigacijska in krmilna oprema	Navigation and control equipment
47.080	Čolni	Small craft

oSIST prEN ISO 10592:2020

en,fr,de

iTeh STANDARD PREVIEW
(standards.iteh.ai)

[kSIST FprEN ISO 10592:2021](#)

<https://standards.iteh.ai/catalog/standards/sist/86172dc9-ebb5-4e02-8670-f4869dab6d16/ksist-fpren-iso-10592-2021>

DRAFT INTERNATIONAL STANDARD

ISO/DIS 10592

ISO/TC 188

Secretariat: SIS

Voting begins on:
2019-12-06Voting terminates on:
2020-02-28

Small craft — Hydraulic steering systems

Navires de plaisance — Appareils à gouverner hydrauliques

ICS: 47.080

iTeh STANDARD PREVIEW (standards.iteh.ai)

[ksIST FprEN ISO 10592:2021](https://standards.iteh.ai/catalog/standards/sist/86172dc9-ebb5-4e02-8670-f4869dab6d16/ksist-fpren-iso-10592-2021)<https://standards.iteh.ai/catalog/standards/sist/86172dc9-ebb5-4e02-8670-f4869dab6d16/ksist-fpren-iso-10592-2021>

THIS DOCUMENT IS A DRAFT CIRCULATED FOR COMMENT AND APPROVAL. IT IS THEREFORE SUBJECT TO CHANGE AND MAY NOT BE REFERRED TO AS AN INTERNATIONAL STANDARD UNTIL PUBLISHED AS SUCH.

IN ADDITION TO THEIR EVALUATION AS BEING ACCEPTABLE FOR INDUSTRIAL, TECHNOLOGICAL, COMMERCIAL AND USER PURPOSES, DRAFT INTERNATIONAL STANDARDS MAY ON OCCASION HAVE TO BE CONSIDERED IN THE LIGHT OF THEIR POTENTIAL TO BECOME STANDARDS TO WHICH REFERENCE MAY BE MADE IN NATIONAL REGULATIONS.

RECIPIENTS OF THIS DRAFT ARE INVITED TO SUBMIT, WITH THEIR COMMENTS, NOTIFICATION OF ANY RELEVANT PATENT RIGHTS OF WHICH THEY ARE AWARE AND TO PROVIDE SUPPORTING DOCUMENTATION.

This document is circulated as received from the committee secretariat.

ISO/CEN PARALLEL PROCESSING



Reference number
ISO/DIS 10592:2019(E)

iTeh STANDARD PREVIEW (standards.iteh.ai)

[ksIST FprEN ISO 10592:2021](https://standards.iteh.ai/catalog/standards/sist/86172dc9-ebb5-4e02-8670-f4869dab6d16/ksist-fpren-iso-10592-2021)
<https://standards.iteh.ai/catalog/standards/sist/86172dc9-ebb5-4e02-8670-f4869dab6d16/ksist-fpren-iso-10592-2021>



COPYRIGHT PROTECTED DOCUMENT

© ISO 2019

All rights reserved. Unless otherwise specified, or required in the context of its implementation, no part of this publication may be reproduced or utilized otherwise in any form or by any means, electronic or mechanical, including photocopying, or posting on the internet or an intranet, without prior written permission. Permission can be requested from either ISO at the address below or ISO's member body in the country of the requester.

ISO copyright office
CP 401 • Ch. de Blandonnet 8
CH-1214 Vernier, Geneva
Phone: +41 22 749 01 11
Fax: +41 22 749 09 47
Email: copyright@iso.org
Website: www.iso.org

Published in Switzerland

Contents

	Page
Foreword	iv
1 Scope	1
2 Normative references	1
3 Terms and definitions	1
4 General requirements	4
5 Materials	6
6 Outboard motors and sterndrives	6
7 Steering system requirements	11
8 Installation	12
9 Test Requirements	15
9.1 Installed proof tests	15
9.2 System application tests	15
9.3 Steering system components tests	15
10 Owner's Manual	18
11 Installation Manual	18
Annex ZA (informative) Relationship between this European Standard and the essential requirements of Directive 2013/53/EU aimed to be covered	20
Bibliography	21

[ksIST FprEN ISO 10592:2021](https://standards.iteh.ai/catalog/standards/sist/86172dc9-ebb5-4e02-8670-f4869dab6d16/ksist-fpren-iso-10592-2021)
<https://standards.iteh.ai/catalog/standards/sist/86172dc9-ebb5-4e02-8670-f4869dab6d16/ksist-fpren-iso-10592-2021>

ISO/DIS 10592:2019(E)

Foreword

ISO (the International Organization for Standardization) is a worldwide federation of national standards bodies (ISO member bodies). The work of preparing International Standards is normally carried out through ISO technical committees. Each member body interested in a subject for which a technical committee has been established has the right to be represented on that committee. International organizations, governmental and non-governmental, in liaison with ISO, also take part in the work. ISO collaborates closely with the International Electrotechnical Commission (IEC) on all matters of electrotechnical standardization.

The procedures used to develop this document and those intended for its further maintenance are described in the ISO/IEC Directives, Part 1. In particular, the different approval criteria needed for the different types of ISO documents should be noted. This document was drafted in accordance with the editorial rules of the ISO/IEC Directives, Part 2 (see www.iso.org/directives).

Attention is drawn to the possibility that some of the elements of this document may be the subject of patent rights. ISO shall not be held responsible for identifying any or all such patent rights. Details of any patent rights identified during the development of the document will be in the Introduction and/or on the ISO list of patent declarations received (see www.iso.org/patents).

Any trade name used in this document is information given for the convenience of users and does not constitute an endorsement.

For an explanation of the voluntary nature of standards, the meaning of ISO specific terms and expressions related to conformity assessment, as well as information about ISO's adherence to the World Trade Organization (WTO) principles in the Technical Barriers to Trade (TBT), see www.iso.org/iso/foreword.html.

This document was prepared by Technical Committee ISO/TC 188, *Small craft*, Subcommittee SC 2, *Engines and propulsion systems*.

This third edition cancels and replaces the second edition (ISO 10592:2017), which has been technically revised.

The main changes compared to the previous edition are as follows:

- Update of the definitions;
- Update of requirements to meet current industry practice;
- Removal of steering wheel requirements and tests;
- Removal of former section 12 - Designation.

Any feedback or questions on this document should be directed to the user's national standards body. A complete listing of these bodies can be found at www.iso.org/members.html.

Small craft — Hydraulic steering systems

1 Scope

This document specifies the requirements for the design, construction, installation and testing of motor mounted and craft mounted remote hydraulic steering systems used with single and multiple engine installations of outboard motors over 15 kW per outboard motor, as well as single and multiple engine inboard, sterndrive, and water jet drives used on small craft up to 24 m length of hull.

In all steering systems, the hydraulic portions of the system shall comply with relevant sections of this document.

This document does not address emergency means of steering the craft.

2 Normative references

The following documents are referred to in the text in such a way that some or all of their content constitutes requirements of this document. For dated references, only the edition cited applies. For undated references, the latest edition of the referenced document (including any amendments) applies.

ISO 8848:2017, *Small craft — Remote steering systems*

3 Terms and definitions

For the purposes of this document, the following terms and definitions apply.

ISO and IEC maintain terminological databases for use in standardization at the following addresses:

— ISO Online browsing platform: available at <https://www.iso.org/obp>

— IEC Electropedia: available at <http://www.electropedia.org/>

3.1

burst pressure

pressure at which the system exceeds the ultimate strength of the weakest hydraulic component resulting in a release of hydraulic pressure

3.2

component interface

mechanical or hydraulic interface at a point in the steering system where a connection is made between components that are not supplied as part of the same assembly kit

Note 1 to entry: If oil lines are not shipped as part of the steering kit, there is an interface between the helm and oil lines, and between the output device and oil lines.

3.3

hydraulic interface

interface between two or more hydraulic components where force and motion are transmitted by hydraulic fluid

3.4

mechanical interface

interface where force and motion are transmitted mechanically

ISO/DIS 10592:2019(E)

3.5

component proof pressure

pressure rating for helms, lines, fittings and output devices which at this pressure the component performs as intended

3.6

component maximum working pressure

pressure equivalent to one-half of the component proof pressure

3.7

drag link (link rod or link arm)

mechanical device used in a steering system by which the force of the output device is transmitted to the steering arm in either a craft mounted or motor mounted steering system

3.8

motor mounted steering system

steering system in which the reactionary forces of the output hydraulic steering device are resisted by the propulsion device

3.9

hydraulic helm

mechanism, exclusive of the steering wheel or other means, through which operator input force is converted to hydraulic pressure and flow

3.10

manual hydraulic system

steering system which utilizes a hydraulic helm to convert operator steering inputs into hydraulic pressure and flow to actuate an output device with no additional energy source

3.11

minimum retained system performance

system capability after test(s) such that at least 90 % of the motor steering arm travel normally available each side of the mid-position may be attained by exertion of no more than 27Nm of torque at the helm through the wheel or other normal control

Note 1 to entry: This criterion does not define steering system performance while a craft is underway, but is intended to provide quantitative limits for design and testing purposes.

3.12

output device

hydraulic cylinder, rotary actuator, or other device that converts hydraulic pressure and flow into force on, and movement of, the steerable device

3.13

rate of steering response

ratio of output movement to input movement

3.14

steering system

assembly, including all components necessary to transmit remote manual effort to the rudder and/or steerable thrust

3.15

craft steering system

assembly that includes all components necessary to transmit remote manual effort to the rudder, sterndrive, waterjet drive, or outboard motor

3.16

motor steering system

assembly that includes all components necessary to transmit remote manual effort from the craft steering system to steerable thrust

3.17 system design peak pressure

3.17.1 single and twin motors: the greater of the pressures generated by the application of either 1672 Newton-meters system torque to the steering axis of the outboard motor(s), inboard, sterndrive, or water jet drive(s), or a single tangential load of 445 Newtons, or system relief pressure if relief activates during application of a 445 Newtons load at the steering wheel rim or handgrip with the maximum diameter wheel specified for the helm

3.17.2 triple and quadruple outboard motors: the greater of the pressures generated by the application of either 3344 Newton-meters system torque to the steering axis of the outboard motors, or a single tangential load of 445 Newton's, or system relief pressure if relief activates during application of a 445 Newton's load at the steering wheel rim or handgrip with the maximum diameter wheel specified for the helm

3.18 system proof pressure

pressure attained by a system if equipped with an activated pressure relief device, or a single tangential load 450 ± 5 N at the steering wheel rim or handgrip with the maximum diameter wheel specified for the helm

3.19 system relief pressure

pressure at which the relief device activates

3.20 system torque

total, combined torque applied to the outboard motor(s) axis (or axes) that is resisted by the component(s) of the steering system (see Figure 1)

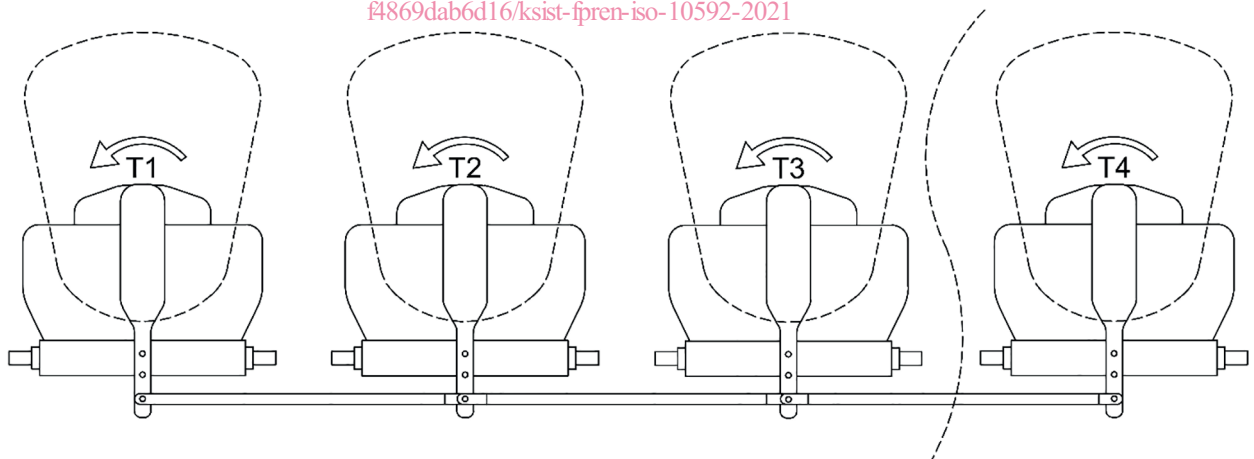

Figure 1 — System torque

3.21 system working pressure

pressure equivalent to one-half of the system proof pressure

3.22 multiple engine installation

two, or more engines, normally used simultaneously for a craft's main propulsion, controlled by a common steering system

ISO/DIS 10592:2019(E)

4 General requirements

4.1 For craft with outboard motors, the crafts steering system shall be complete to the component interface for connection to the drag link supplied with the motor, or provide an alternative means to connect the output device to the motor such that the loading magnitude and offset are consistent with the tiller arm's intended purpose. In all other crafts, the steering system shall be complete to the output connection point.

4.2 All threaded fasteners whose integrity affects operation of the system such that separation or loss of the fastener would cause sudden loss of steering without warning shall be provided with a locking means.

EXCEPTION: Hydraulic fittings

4.3 Threaded fasteners whose integrity affects operation of the system such that separation or loss of the fasteners would cause sudden loss of steering without warning, and that may be expected to be disturbed by installation or adjustment procedures, shall be referenced by instructions for correct assembly, and

4.3.1 shall be locked by a device whose presence is determined by visual inspection, or by feel, following assembly, or

4.3.2 shall incorporate integral locking means, provided the fastener cannot be omitted or substituted without making the system inoperable.

EXCEPTION: Hydraulic fittings

NOTE 1 Self-locking nuts with plastic inserts that create mechanical plastic interference meet the requirements of [section 4.5](#) and its sub-sections.

NOTE 2 Loose lock washers, distorted thread nuts, or adhesives do not meet the requirements of [section 4.3](#) and its sub-sections.

4.3.3 Devices that use plain threaded jam nuts to permit adjustments shall be designed so that total separation of parts, or other complete loss of steering, will not occur should they loosen.

NOTE Connection fittings, including "quick disconnect" fittings, relying solely on a spring or springs for connection integrity, do not meet the requirements of this section.

4.4 Operating temperature range – All materials used in construction of the system and its accessories must be capable of operating from -20°C to +80°C. Hydraulic system components shall not be installed in areas where the operating temperature exceeds +80°C.

4.5 Storage Temperature Range - All materials used in construction of the system and its accessories shall be capable of withstanding an ambient temperature of -40°C to 85°C for at least 1 week duration.

NOTE This requirement is not intended to require operation at these temperatures, but is included to determine that the system will withstand the stipulated storage temperatures.

iteh STANDARD PREVIEW
(standards.iteh.ai)

KSIST prEN ISO 10592:2021

<https://standards.iteh.ai/catalog/standards/sist/86172dc9-ebb5-4e02-8670-f4869dab6d16/ksist-pr-en-iso-10592-2021>

4.6 All components including, but not limited to, hydraulic lines and fittings, input and output devices, shall be selected to have a component proof pressure rating no less than the proof pressure rating on the hydraulic helm as indicated by the manufacturer of the helm. (See [Figure 2](#)).

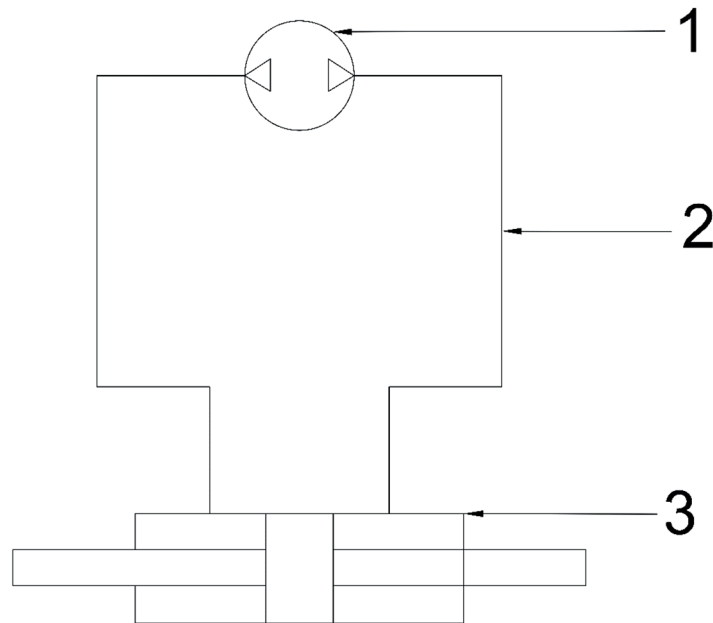

Key

- 1 Helm marking: system proof pressure = 6900 kPa
- 2 Line marking: ≥ 6900 kPa proof pressure rating or ≥ 3450 working pressure rating
- 3 Cylinder marking: ≥ 6900 kPa proof pressure rating or ≥ 3450 kPa working pressure rating

<https://standards.iteh.ai/catalog/standards/sist/86172dc9-ebb5-4e02-8670-8f9a0c17a379/iso-10592-2021>

Figure 2 — Typical system schematic

4.7 Components shall have a burst pressure that is no less than the system design peak pressure throughout the normal temperature range and expected burst pressure variation due to manufacture, installation, environmental exposure, and service loading, or two times component proof pressure whichever is greater.

4.8 Hydraulic lines and fittings shall be selected in accordance with steering equipment manufacturers' instructions, and in consideration with the guidelines in Annex A.

NOTE Flareless fittings are not recommended above 3450 kPa system working pressure.

4.8.1 Hydraulic quick connect fittings whose integrity affects operation of the system such that separation or loss of the connection would cause sudden loss of steering without warning shall incorporate a two stage integral locking means for connection integrity.

4.9 The hydraulic steering system, including any pressure relief devices, shall not allow more than 17 degrees of steering movement about the steering axis of the steerable device, initiating at the centre and within 13 degrees of centre, under shock load applied to the steerable device equivalent to system design peak pressure.

NOTE The shock movement requirement is based on an impulse load applied to the steerable device, and resisted by the steering system with peak amplitude equivalent to at least design peak pressure and with at least one-half design peak pressure acting for a duration of at least one-half second.