



# Standard Test Method for Comparing Metal Removal Fluids Using the Tapping Torque Test Machine<sup>1</sup>

This standard is issued under the fixed designation D 5619; the number immediately following the designation indicates the year of original adoption or, in the case of revision, the year of last revision. A number in parentheses indicates the year of last reapproval. A superscript epsilon ( $\epsilon$ ) indicates an editorial change since the last revision or reapproval.

## 1. Scope

1.1 This test method covers a laboratory technique to evaluate the relative performance of metal removal fluids using a non-matrix test protocol using the tapping torque test machine.

1.2 The values stated in SI units are to be regarded as standard. Because the equipment used in this test method is available only in inch-pound units, SI units are omitted when referring to the equipment and the test pieces.

1.3 *This test method does not purport to address all of the safety concerns, if any, associated with its use. It is the responsibility of the user of this standard to establish appropriate safety and health practices and determine the applicability of regulatory limitations prior to use.*

## 2. Terminology

### 2.1 Definitions of Terms Specific to This Standard:

2.1.1 *build-up edge*—a triangular deposit that forms adjacent to the cutting edge on the face of the tool in a metalworking operation.

2.1.1.1 *Discussion*—The high contact pressure between the cutting edge of the tap and the specimen material results in a high temperature. The high temperature, the wear debris, the high contact pressure, and some of the constituents of the cutting fluid combine at the cutting edge and form a triangular deposit, referred to as a built-up edge (BUE). The BUE is sustained by the chip curl as it is passed over, and as the BUE grows, it is abraded by the rubbing of the chip curl. Since the BUE is located exactly where the curl is generated, it contributes to the size of the curl; the larger the BUE, the larger the diameter of the chip curl. A small chip curl will flow smoothly up the flute of the tap and will not affect the torque. However, a large curl will drag and jam in the flute and will contribute to the tapping torque.

If a new tap is utilized, it is necessary to run several tests to run-in the tap. This process prepares the cutting edge to receive a characteristic BUE, depending on which cutting fluid is

utilized.

If a cutting fluid is changed to another cutting fluid during a test sequence, it is necessary to discard the results from at least the first test of the new fluid since the previous BUE must be abraded or modified with the chemistry of the new fluid to form its own characteristic BUE.

The ideal cutting fluid forms a small, stable BUE that assists in the formation of a small curl.

## 3. Summary of Test Method

3.1 The torque required to tap a thread in a blank specimen nut while lubricated with a metal removal fluid is measured and compared with the torque required to tap a thread in a blank specimen nut while lubricated with a reference fluid. See Fig. 1. The ratio of the average torque values of the reference oil to the metal removal fluid tested, when using the same tap, is expressed as the percent efficiency of the fluid. The efficiency of two or more fluids can be compared when the average torque values of the reference fluid on different taps are considered to be statistically equivalent.

## 4. Significance and Use

4.1 The procedures described in this test method can be used to predict more accurately the lubricating properties of a metal removal fluid than previously available laboratory scale tests.

4.2 This test method is designed to allow flexibility in the selection of test specimen metal composition, tap alloy or coatings, and machining speeds.

4.3 Comparison between various types of fluids can be made, including cutting oils, soluble oils, semi-synthetics, or water soluble synthetics.

## 5. Apparatus

5.1 *Test Machine*, the tapping torque test machine<sup>2</sup> as illustrated in Fig. 2 and Fig. 3.

5.2 *Plastic Squeeze Bottle*, 100 mL or larger, Nalgene or its equivalent.

5.3 *GO/NO GO Wire Plug Gage*<sup>2</sup>, 0.3360/0.3363 in.

5.4 *Drying Oven*, controllable to  $52 \pm 3^\circ\text{C}$  ( $125 \pm 5^\circ\text{F}$ ).

<sup>1</sup> This method is under the jurisdiction of ASTM Committee D02 on Petroleum Products and Lubricants and is the direct responsibility of Subcommittee D02.L0.01 on Metal Removal Fluids and Lubricants.

Current edition approved Nov. 10, 2000. Published December 2000. Originally published as D 5619 – 94. Last previous edition D 5619 – 94.

<sup>2</sup> This test method was conducted using apparatus and materials available from Faxel Corp., 1020 Airpark Dr., Sugar Grove, IL 60554.

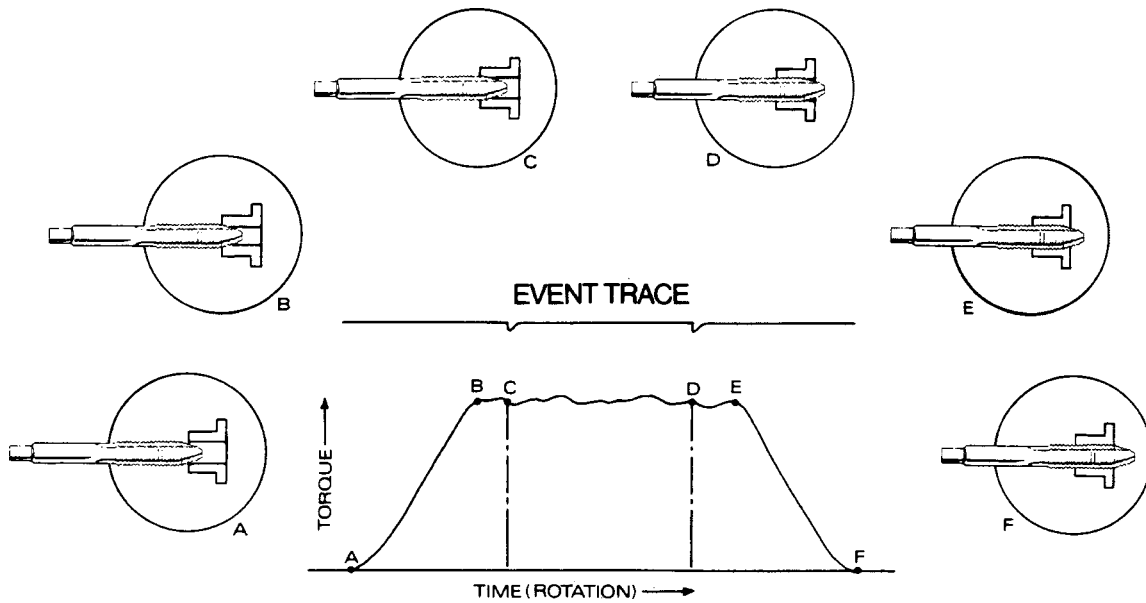

FIG. 1 Tapping Torque Curve (insets show position of tap in specimen blank)

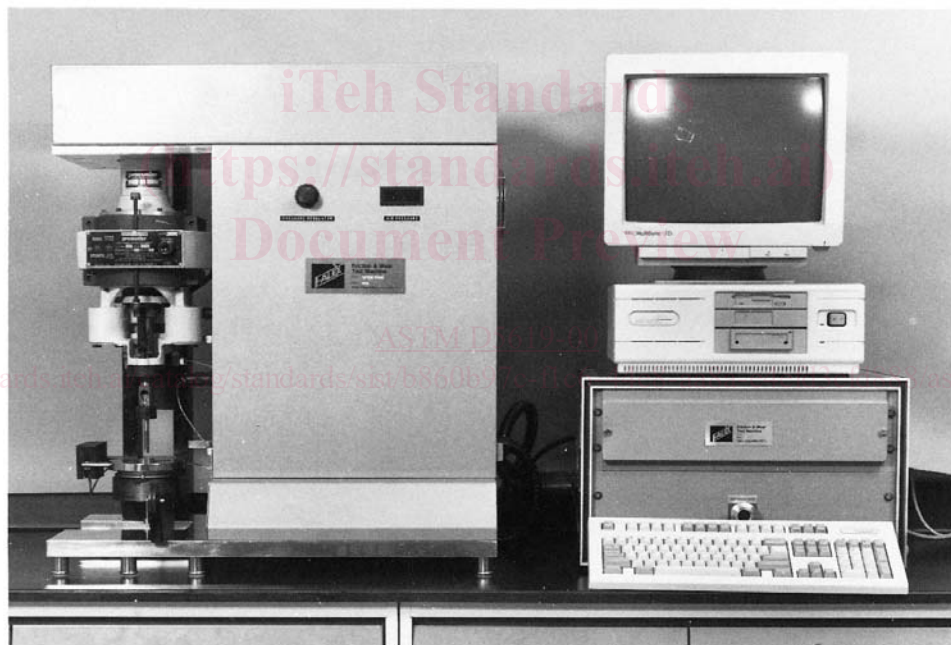

FIG. 2 Falex Tapping Torque Test Machine

**6. Reagents and Materials**

6.1 *Cutting Nut Blanks*, inside diameter of  $0.33615 \pm 0.00015$  in., material selected by the user of the test method. 1215 steel alloy is recommended to be used for qualifying taps.

6.2 *Cutting Tap*, 10 by 1.5 mm.

6.3 *Reference Fluid*, a stable fluid that produces minimal build-up edge on tap and yields repeatable test results.

NOTE 1—Any lubricant can be used as the reference fluid. However, it is recommended that the reference fluid *not* contain additives that will react with metal, such as sulfur, chlorine, or phosphorus containing EP additives, as these could react with the tap during the tap qualification and potentially bias the results of the test fluid. An ISO Grade 22 (90–100

SUS) mineral oil containing approximately 5 to 6 % lard has been found to be an effective reference fluid.

6.4 *Solvent*, safe, nonfilming, nonchlorinated.

NOTE 2—Each user should select solvents that can meet applicable safety standards and still thoroughly clean the test parts. Technical grade Naptha or Stoddard Solvent and reagent grade acetone have been found satisfactory.

**7. Preparation of Samples**

7.1 For cutting oils and the reference fluid, transfer a minimum of 100 mL of the fluid to be tested to a clean plastic squeeze bottle.

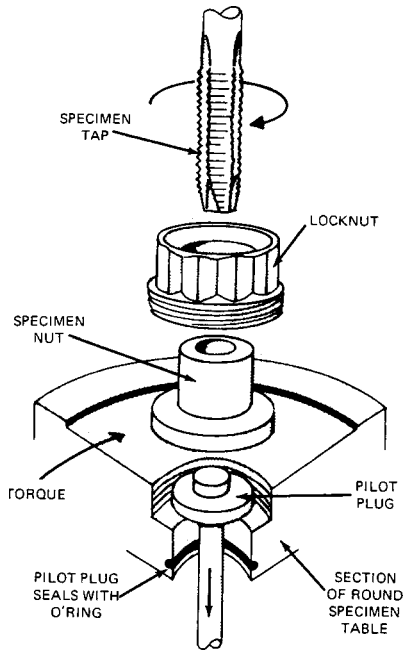

FIG. 3 Exploded View of Specimen Alignment

7.2 For water soluble fluids, prepare a minimum of 100 mL of diluted fluid to be tested from the sample concentrate with water (make a note of concentration and water quality; for example, tap, deionized, hardness, etc.) to the selected concentration and transfer to a plastic squeeze bottle.

**8. Preparation of Test Nut Blanks and Taps**

8.1 Clean taps and nut blanks in a sonic cleaner using solvent selected in 6.3 for at least 15 min. Oven dry at 52 ± 3°C (125 ± 5°F). Store in a desiccator.

NOTE 3—The use of technical grade naphtha or Stoddard Solvent followed by two rinses with reagent grade acetone and air drying has been found satisfactory.

NOTE 4—Taps should be checked carefully for nicks or any residual metal preservative before they are used. If any nicks are detected, the tap should be discarded. If residual metal preservative is evident, reclean as in 8.1. A soft brush, such as a toothbrush, can be used to aid in removing any residue. A test tube brush may aid in removing metal preservatives from within the test nut blanks.

8.2 Before using nut blanks, the internal hole diameter should be checked with the GO/NO GO wire plug gage in 5.3. Discard any specimen nuts that are outside of this range.

**9. Preparation of Apparatus**

9.1 Zero the chart recorder according to the equipment manufacturer's instructions.

9.2 Zero the torque indicator on the test machine.

NOTE 5—When setting zeros (9.1 and 9.2) be sure to turn the specimen turntable counterclockwise, away from the load cell, to remove any preload so that the meters can be zeroed properly.

9.3 Calibrate the torque by placing the average torque integrator in the CALB or calibration position. Attach the calibrator pulley to the lower plate of the test machine according to the manufacturer's directions. Attach cable by feeding the end of the cable under the torque arm and securing

it in the slotted pin under the specimen table at the 6 o'clock position. Calibrate the average torque meter by hanging a known weight on the hook at the end of the cable. If the torque meter readout does not agree with the torque reading expected with the weight on the hook, adjust the span. Consult the manufacturer's instruction manual for further details.

9.4 Place average torque integrator to the average position.

9.5 Set torque trigger point to 0.5 N-m.

NOTE 6—When using nut blanks of softer materials such as aluminum, a lower torque trigger point of 0.2 N-m should be used.

9.6 Select torque averaging initial and final values according to the equipment manufacturer's instructions, depending on the torque curve generated during test run and the desired area for evaluation.

NOTE 7—Two hundred sixty and 560 revolutions times 60, or that equivalent to 3 1/2 to 9 1/3 revolutions has been found to give effective data over the full working range of the tap in the nut blank.

**10. Cutting Tap Qualification**

10.1 Set test machine to desired speed.

NOTE 8—Test cutting speed is dependent on nut blank material. Consult a machinist's handbook for recommended cutting speeds; 400 rpm is recommended for 1215 steel.

10.2 Select a new tap and install it in the test equipment according to the equipment manufacturer's instructions.

10.3 Install a clean, unused nut blank on the table of the test machine and secure to a torque of 25 in-lb according to the manufacturer's instructions.

10.4 Lower pilot guide plug from center of nut blank to the sealing position. Fill nut blank and coat tap with reference fluid chosen in 6.4.

NOTE 9—A special tool is supplied with the test equipment to effect the correct distance. The sealing position allows for the entire nut blank cavity to be filled with the test fluid specimen.

10.5 Start test run.

10.6 Apply a continuous stream of reference fluid to tap throughout the test run using a squeeze bottle in 5.2.

10.7 After the test run is complete, record the average torque value.

10.8 Remove the used nut blank and clean the tap using sufficient solvents, selected in 6.3, and compressed air to remove test fluid, solvent, and metal chips. Leave tap on test machine during this cleaning procedure.

NOTE 10—Rinse with solvent chosen in 6.3 or as listed in Note 3.

10.9 Inspect tap for evidence of built-up edge. If built up edge exists, discard tap and begin from 10.2 using a reference fluid that minimizes the formation of built-up edge. Build-up edge can cause variability in test results.

10.10 Repeat 10.3 to 10.9 five times. Determine the arithmetic mean and standard deviation of the five torque values. If the standard deviation is within ± 2 % of the mean value, the tap is acceptable as a reference tap. Save this tap.

10.11 Repeat 10.2 to 10.10 with a clean, new tap.

10.12 Determine the arithmetic mean and standard deviation of the torque values. If the standard deviation of the torque values is within ± 2 % of the mean and the difference of the