Inflatable play equipment — Safety requirements and test methods

Équipements de jeux gonflables — Exigences de sécurité et méthodes d'essai

iTeh STANDARD PREVIEW
(standards.iteh.ai)

[ISO 20187:2016](https://standards.iteh.ai/catalog/standards/sist/7c5d7f77-4e46-4e2f-808e-7212a5a6940a/iso-20187-2016)

<https://standards.iteh.ai/catalog/standards/sist/7c5d7f77-4e46-4e2f-808e-7212a5a6940a/iso-20187-2016>



iTeh STANDARD PREVIEW
(standards.iteh.ai)

ISO 20187:2016

<https://standards.iteh.ai/catalog/standards/sist/7c5d7f77-4e46-4e2f-808e-7212a5a6940a/iso-20187-2016>



COPYRIGHT PROTECTED DOCUMENT

© ISO 2016, Published in Switzerland

All rights reserved. Unless otherwise specified, no part of this publication may be reproduced or utilized otherwise in any form or by any means, electronic or mechanical, including photocopying, or posting on the internet or an intranet, without prior written permission. Permission can be requested from either ISO at the address below or ISO's member body in the country of the requester.

ISO copyright office
Ch. de Blandonnet 8 • CP 401
CH-1214 Vernier, Geneva, Switzerland
Tel. +41 22 749 01 11
Fax +41 22 749 09 47
copyright@iso.org
www.iso.org

Contents

| | Page |
|---|-----------|
| Foreword | v |
| Introduction | vi |
| 1 Scope | 1 |
| 2 Normative references | 1 |
| 3 Terms and definitions | 1 |
| 4 Safety requirements | 4 |
| 4.1 Materials..... | 4 |
| 4.1.1 Fabrics..... | 4 |
| 4.1.2 Thread..... | 4 |
| 4.1.3 Netting..... | 4 |
| 4.1.4 Ropes..... | 5 |
| 4.1.5 Zips..... | 5 |
| 4.1.6 Dangerous substances and decorative finishes..... | 5 |
| 4.2 Design..... | 5 |
| 4.2.1 Anchorage..... | 5 |
| 4.2.2 Structural Integrity..... | 6 |
| 4.2.3 Access/Egress..... | 7 |
| 4.2.4 Blowers..... | 10 |
| 4.2.5 Entrapment..... | 10 |
| 4.2.6 Hard objects, sharp angles, and edges..... | 14 |
| 4.2.7 Electrical installations..... | 14 |
| 4.2.8 Siting..... | 14 |
| 4.2.9 Containment..... | 16 |
| 4.2.10 Wall heights on slopes..... | 17 |
| 4.2.11 Run-outs..... | 18 |
| 4.2.12 Ventilation..... | 18 |
| 4.3 Number of users..... | 18 |
| 4.4 Supervision..... | 19 |
| 5 Test methods and reports | 19 |
| 6 Information to be provided by the supplier/manufacturer | 19 |
| 6.1 General product information..... | 19 |
| 6.2 Pre-information..... | 19 |
| 6.3 Installation information..... | 20 |
| 6.4 Operating information..... | 20 |
| 6.5 Inspection and maintenance information..... | 21 |
| 7 Inspection, maintenance, and alteration | 21 |
| 7.1 Inspection..... | 21 |
| 7.1.1 Routine Inspection..... | 21 |
| 7.1.2 Annual inspection..... | 21 |
| 7.2 Maintenance..... | 22 |
| 7.2.1 General..... | 22 |
| 7.2.2 Routine maintenance..... | 22 |
| 7.2.3 Corrective maintenance..... | 22 |
| 7.3 Alteration..... | 22 |
| 8 Marking | 22 |
| 9 Documentation | 23 |
| Annex A (normative) Calculation of number of anchor-points | 24 |
| Annex B (informative) Beaufort Scale of wind force | 25 |
| Annex C (normative) Test method for grounding | 26 |

| | |
|--|-----------|
| Annex D (normative) Test methods for entrapment | 27 |
| Annex E (normative) Test method for tear strength | 37 |
| Bibliography | 42 |

iTeh STANDARD PREVIEW
(standards.iteh.ai)

ISO 20187:2016

<https://standards.iteh.ai/catalog/standards/sist/7c5d7f77-4e46-4e2f-808e-7212a5a6940a/iso-20187-2016>

Foreword

ISO (the International Organization for Standardization) is a worldwide federation of national standards bodies (ISO member bodies). The work of preparing International Standards is normally carried out through ISO technical committees. Each member body interested in a subject for which a technical committee has been established has the right to be represented on that committee. International organizations, governmental and non-governmental, in liaison with ISO, also take part in the work. ISO collaborates closely with the International Electrotechnical Commission (IEC) on all matters of electrotechnical standardization.

The procedures used to develop this document and those intended for its further maintenance are described in the ISO/IEC Directives, Part 1. In particular the different approval criteria needed for the different types of ISO documents should be noted. This document was drafted in accordance with the editorial rules of the ISO/IEC Directives, Part 2 (see www.iso.org/directives).

Attention is drawn to the possibility that some of the elements of this document may be the subject of patent rights. ISO shall not be held responsible for identifying any or all such patent rights. Details of any patent rights identified during the development of the document will be in the Introduction and/or on the ISO list of patent declarations received (see www.iso.org/patents).

Any trade name used in this document is information given for the convenience of users and does not constitute an endorsement.

For an explanation on the meaning of ISO specific terms and expressions related to conformity assessment, as well as information about ISO's adherence to the WTO principles in the Technical Barriers to Trade (TBT) see the following URL: [Foreword - Supplementary information](#)

The committee responsible for this document is ISO/TC 83, *Sports and other recreational facilities and equipment*.

ISO 20187:2016

<https://standards.iteh.ai/catalog/standards/sist/7c5d7f77-4e46-4e2f-808e-7212a5a6940a/iso-20187-2016>

Introduction

Play is the means by which children discover and understand the world in which they live and is an essential element in a child's physical and mental growth.

It is important for children's rounded development that, through play, they arrive at an understanding of danger which provides a basis for assessing safety in a variety of situations. The balance between challenge and safety is an important consideration.

The inflatable play equipment referred to in this International Standard can provide different levels of challenge and recreation. This International Standard aims to minimize the level of risk and the possibility of serious injury while allowing children to enjoy themselves when playing in or on inflatable equipment.

This International Standard acknowledges the difficulties of addressing safety issues by age criteria alone because the ability to handle risk is based on the individual user's level of skill and not age. Moreover, users other than the intended age range will make use of the inflatable equipment, in which case, the provisions of this International Standard still apply.

It is not the purpose of the requirements of this International Standard to affect a child's need to play, nor to lessen the contribution that inflatable play equipment makes either to the child's development or meaningful play from an educational point of view.

Where inflatable play equipment is combined with other items of children's playground equipment, the relevant standards applying to the other items of equipment is to also be consulted.

iTeh STANDARD PREVIEW **(standards.iteh.ai)**

ISO 20187:2016

<https://standards.iteh.ai/catalog/standards/sist/7c5d7f77-4e46-4e2f-808e-7212a5a6940a/iso-20187-2016>

Inflatable play equipment — Safety requirements and test methods

1 Scope

This International Standard is applicable to inflatable play equipment intended for use by children up to 14 years of age individually and as a group activity.

This International Standard specifies safety requirements for inflatable play equipment for which the primary activities are bouncing and sliding. It sets measures to address risks and also to minimize accidents to users for those involved in the design, manufacture, and supply of inflatable play equipment. It specifies information to be supplied with the equipment. The requirements have been laid down bearing in mind the risk factor based on available data.

This International Standard specifies the requirements that will protect a child from hazards that he or she may be unable to foresee when using the equipment as intended or in a manner that can be reasonably anticipated.

This International Standard is not applicable to inflatable water-borne play and leisure equipment, domestic inflatable toys, air-supported buildings, inflatables used solely for protection, inflatables used for rescue, or other types of inflatable toys where the primary activity is not bouncing or sliding.

2 Normative references

The following documents, in whole or in part, are normatively referenced in this document and are indispensable for its application. For dated references, only the edition cited applies. For undated references, the latest edition of the referenced document (including any amendments) applies.

ISO 2307, *Fibre ropes — Determination of certain physical and mechanical properties*

ISO 8124-3, *Safety of toys — Part 3: Migration of certain elements*

ISO 9554, *Fibre ropes — General specifications*

ISO/IEC 17025, *General requirements for the competence of testing and calibration laboratories*

IEC 60529, *Degrees of protection provided by enclosures (IP code)*

EN 1177, *Impact attenuating playground surfacing — Determination of critical fall height*

3 Terms and definitions

For the purposes of this document, the following terms and definitions apply.

NOTE In order not to confine the application of this International Standard to those items of equipment currently in use, and hence, allow freedom of design for the manufacture of new equipment, only the fundamental forms of equipment and motion are listed.

3.1 inflatable play equipment

structure relying on a continuous supply of air to maintain its shape on or in which users may play, bounce, and/or slide

Note 1 to entry: Also referred to as an/the inflatable.

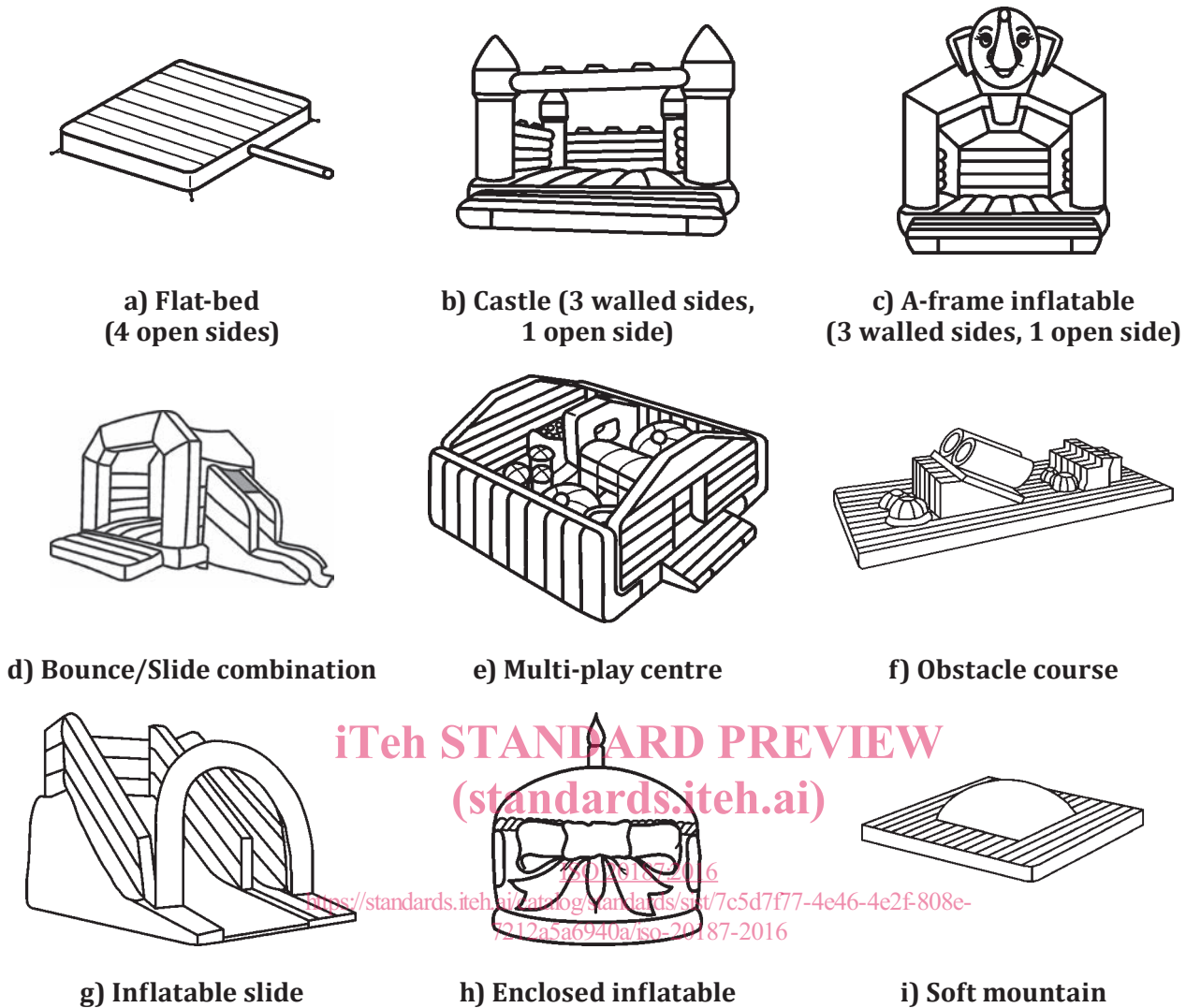

Figure 1 — Examples of inflatable play equipment

3.2

blower

powered machine used to continuously inflate the structure

3.3

connection tube

part of the inflatable structure to which the *blower* (3.2) is connected

3.4

controller

person, company, or hirer (those who hire to others) having responsibility for the overall control, inspection, and maintenance of the equipment

3.5

operator

person appointed by a *controller* (3.4) to be in charge of the operation of the equipment at any time when it is available for use by the public

3.6

attendant

person working under the control and direction of an *operator* (3.5) to assist in the operation of the equipment

3.7**inspection body**

organization, part of an organization or individual with the appropriate competence to carry out one or more of the following inspections:

- design review;
- assessment of conformity to design;
- initial testing;
- annual main inspection

3.8**free height of fall**

greatest vertical distance from the clearly intended body support to the *impact area* (3.16) below

[SOURCE: ISO 8124-4:2014, 3.8, modified]

3.9**critical fall height**

maximum free heights of fall for which a surface will provide an acceptable level of impact attenuation

3.10**open side**

any external side of an inflatable with no containing wall

3.11**step**

step to aid the access/egress of users into and out of the *playing area* (3.22) of the inflatable making the transition between the height of the playing area and the ground

3.12**ramp**

ramp to aid the access/egress of users into and out of the *playing area* (3.22) of the inflatable making the transition between the height of the playing area and the ground

3.13**platform**

surface on which a user may stand

3.14**squeeze**

play item which is often attached to and forms part of *inflatable play equipment* (3.1), the purpose of which is to squeeze the user whilst not entrapping them while allowing the user to pass through a gap with a degree of difficulty

3.15**entrapment**

hazard in which a body, or part of a body, or clothing, can become trapped

3.16**impact area**

area surrounding the *open side(s)* (3.10) of an inflatable

3.17**run-out**

intended deceleration zone at the bottom of a slide

3.18**anchorage system**

method of fixing an inflatable to the ground using stakes

3.19

ballast system

method of fixing an inflatable to the ground using weights

3.20

user height

maximum height of persons allowed to use the inflatable

3.21

free space

space in, on, or around the inflatable that can be occupied by a user undergoing a movement forced by the equipment (for example, sliding, bouncing)

3.22

playing area

space in or on the inflatable intended for play

3.23

falling space

space in or around the inflatable that can be passed through by a user falling from an elevated part of the equipment

Note 1 to entry: The falling space commences at the *free height of fall* (3.8).

4 Safety requirements

ITeh STANDARD PREVIEW
(standards.iteh.ai)

4.1 Materials

4.1.1 Fabrics

ISO 20187:2016

Fabrics shall be flame retardant.
<https://standards.iteh.ai/catalog/standards/sist/7c5d7f77-4e46-4e2f-808e-7212a5a6940a/iso-20187-2016>

Fabrics and joints in fabrics shall be of adequate tear and tensile strength for the weight of the intended user and have sufficient air retention to enable the inflatable, when pressurized to the level specified in the operations manual, to resume its shape after distortion under load.

The following fabrics shall be used in those structural parts of the inflatable where force or stress is applied by the user:

- a) minimum tear strength 350 N (see test method Annex E);
- b) minimum tensile strength 1 850 N (see ISO 1421);
- c) minimum coating adhesion 100 N (see ISO 2411).

4.1.2 Thread

Threads shall be non-rotting yarn and at least 88 N tensile strength. Stitching shall be lock-stitch. The length of individual stitches shall be a minimum of 3 mm and a maximum of 8 mm.

4.1.3 Netting

Retention netting is commonly used to define the playing area to contain the users and to retain items of mobile play equipment, such as balls. Retention netting shall not significantly impair visibility. Retention netting shall be strong enough to contain the largest/heaviest user for whom the inflatable is designed.

In order to prevent users from climbing retention netting the mesh size, where the netting is more than 1 m vertical height and accessible to the user, shall be 30 mm or less to exclude users' feet.

Where netting is used for roofs and is accessible to the user, the mesh size shall be small enough to prevent the 8 mm finger rod from passing through (see [Figure 2](#)).

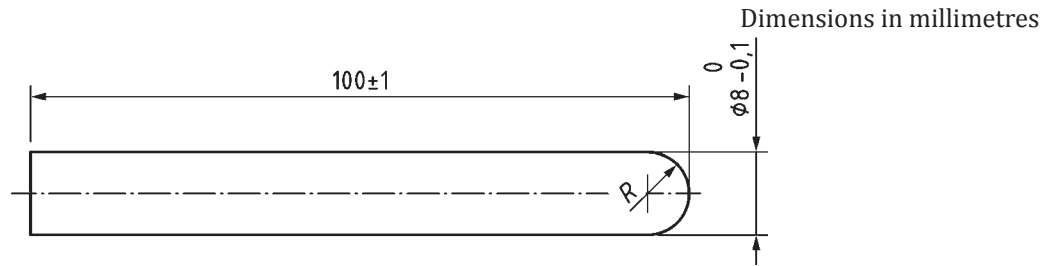

Figure 2 — 8 mm finger rod

Clamber netting (commonly laid on slopes to form foot and hand holds) shall be securely fixed to prevent lifting by the user. The rope from which it is made shall be at least 12 mm in diameter and shall be securely knotted. Strand ends shall be treated to prevent fraying. Care shall be taken when heat sealing so as not to form hard or sharp edges.

4.1.4 Ropes

Ropes shall be fixed at both ends and the total amplitude of swing shall not exceed 20 % of the distance between the fixing points, such that it shall not be possible to make a loop in the rope of large enough diameter to allow probe E to pass through (see [Figure D.1](#)).

NOTE This requirement is intended to remove the risk of strangulation.

The rope diameter shall be between 18 mm and 45 mm.

Fibre ropes (textile type) shall conform to ISO 9554 or ISO 2307. Alternatively, a works certificate shall be supplied stating the material used and the safe working load. Monofilament plastics ropes shall not be used.

4.1.5 Zips

Zips shall withstand air pressures and tension generated within the structure. Zips used for entrances and exits shall be reliable, easy to use, able to open from both sides, and shall allow access and egress by adults. Zips used for deflation purposes shall have the puller hidden from view (e.g. by a flap or pocket).

4.1.6 Dangerous substances and decorative finishes

Dangerous substances shall not be used for inflatable play equipment in such a way that they can cause adverse health effects to the user. Paints and other decorative finishes shall conform to ISO 8124-3.

NOTE Attention is drawn to the provisions of European Regulation (EC) No. 1907/2006.^[4] Such materials include, for example, asbestos, lead, formaldehyde, coal tar oils, carbolineums, and polychlorinated biphenyls (PCBs).

4.2 Design

4.2.1 Anchorage

The inflatable shall be provided with an anchorage and/or ballast system and any necessary accessories enabling the inflatable to be securely fixed to the ground. Each inflatable shall have at least six anchorage points.

The number of anchorage points shall be calculated in accordance with Annex A. They shall be distributed around the perimeter of the inflatable (see also [4.2.3](#)) and shall be fitted with metal ends.

The maximum wind-speed in which inflatables shall be used outdoors is 38 km/h (Force 5 on the Beaufort Scale; see Annex B).

When used outdoors, the inflatable shall be secured to the ground, preferably with ground stakes where the ground is suitable. Each anchorage point on the inflatable and all of the components of the anchorage and/or ballast system, e.g. ropes, webbings, metal attachments, stakes, and weights shall withstand a force of 1 600 N. The direction of the exerted force shall be at an angle to the ground of 30° to 45°. Ground stakes shall incline away from the direction of the exerted force. Ground stakes shall be a minimum of 380 mm in length and a minimum of 16 mm in diameter and their tops shall be rounded. The system shall expose no more than 25 mm of the stake above ground level (see [Figure 3](#)).

When the inflatable is used indoors, the anchorage and/or ballast system should be used, when necessary, to maintain stability.

Dimensions in millimetres

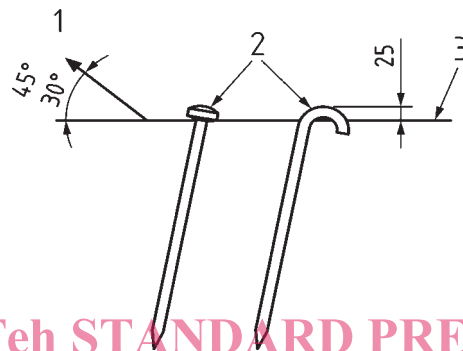

iTeh STANDARD PREVIEW
(standards.iteh.ai)

Key

- 1 direction of force
- 2 rounded tops
- 3 ground level

ISO 20187:2016
<https://standards.iteh.ai/catalog/standards/sist/7c5d7f77-4e46-4e2f-808e-7212a5a6940a/iso-20187-2016>

Figure 3 — Examples of ground stakes

On hard standing where ground stakes cannot be used, the inflatable shall be secured to the ground by equally effective method, e.g. attaching each of the anchorage points to fittings already in the ground, or to sandbags or other weights, if these are capable of supporting the 1 600 N load. If the inflatable is secured to a vehicle or other movable machinery, such vehicles or machinery shall be immobilized and be under the control of an operator.

4.2.2 Structural Integrity

The minimum air pressure inside the structural parts of the inflatable shall be 1 kPa (100 mm water gauge). Inflated chambers that are entered by the user are not considered to be structural parts of the inflatable, e.g. enclosed dome type inflatables. Pressure in the playing area of soft mountains shall be no greater than 0,25 kPa (25 mm water gauge), but shall maintain a pressure sufficient to prevent grounding. Pressure in the surrounding safety apron of soft mountains shall be at least 1 kPa (100 mm water gauge; see [Figure 4](#)).

The depth of the trough on the surface of any platform shall be a maximum of 33 % of the width of the adjacent panel measured when inflated (see [Figure 5](#)).

Containing walls shall be vertical (90 ± 5)°. Towers that support containing walls shall be in the same plane. Containing walls and towers shall be strong enough to contain the largest and/or heaviest user for whom the inflatable is designed.

Playing areas, surrounding safety aprons, steps, and/or ramps shall support the weight of the largest and/or heaviest user for whom the inflatable is designed without grounding (see Annex C for the test method).

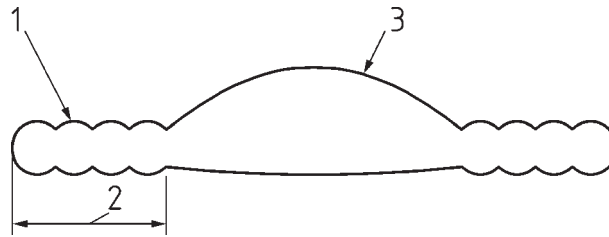
**Key**

- 1 surrounding safety apron
- 2 tread depth
- 3 playing area

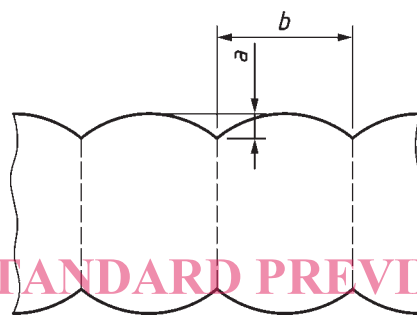
Figure 4 — Section through a soft mountain**Key**

a depth of trough — measured when inflated

b width of adjacent panel

ISO 20187:2016
<https://standards.iteh.ai/catalog/standards/sist/7c5d7f77-4e46-4e2f-808e-7212a5a6940a/iso-20187-2016>

Figure 5 — Trough depth**4.2.3 Access/Egress**

A step or ramp shall be wide enough to cover the entire access/egress aperture with overlap according to [Figure 6](#).

A step or ramp shall have a tread depth of a minimum of 1,5 times the height of the adjacent playing area platform to which it is attached (see [Figure 6](#)).

The playing area of soft mountains shall be completely surrounded by an inflated safety apron. This safety apron shall have a minimum tread depth of 1,6 m times or 0,5 times the height of the playing area measured from the ground when inflated and in the unloaded condition, whichever is greater.

In the event of air supply failure, the deflation time shall be sufficient to allow users of the inflatable to be evacuated safely.

NOTE Deflation time can be considerably lengthened by inserting a non-return flap in the outlet nozzle of the blower or at the joint of the connection tube and structure.

Inflatables shall be designed to ensure that adults are able to gain access in order to assist users.

On any open side, the free height of fall shall be no greater than 630 mm from the ground in the unloaded condition (600 mm in the loaded condition).

On any open side, the extent of the impact area shall be at least 1,2 m. The surface in the impact area shall meet the requirements for impact attenuation so that the critical fall height of the surfacing, according to EN 1177 or National equivalent impact attenuation test method, is at least 630 mm. The impact areas

of adjacent inflatables and/or other play equipment shall not overlap. Materials such as soil, turf, and sand have some impact-attenuating properties. Impact-absorbing mats may be used (see [Figure 7](#)).

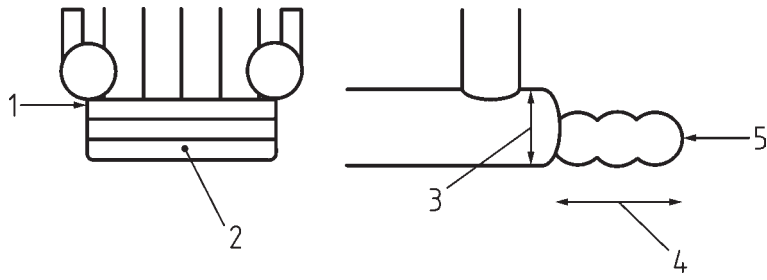

a) step detail

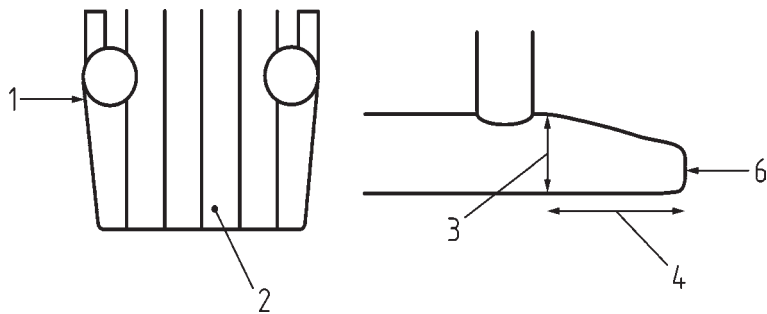

b) ramp detail

iTeh STANDARD PREVIEW
(standards.iteh.ai)

Key

- | | | | |
|---|--|---|-------------|
| 1 | overlap | 4 | tread depth |
| 2 | open side | 5 | step |
| 3 | height of adjacent playing area platform | 6 | ramp |

Figure 6 — Step or ramp detail

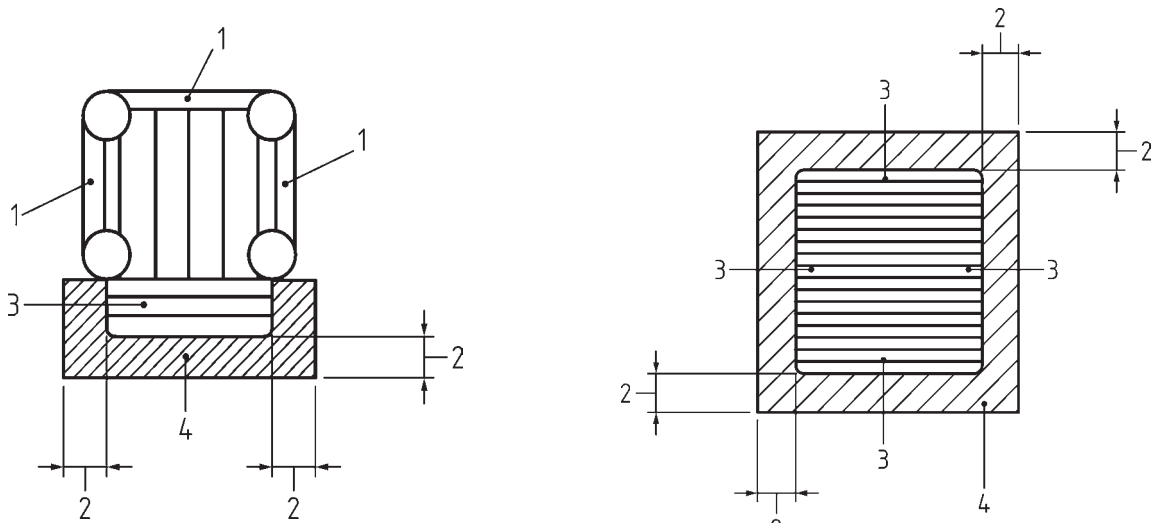

a) Castle type

b) Flat-bed

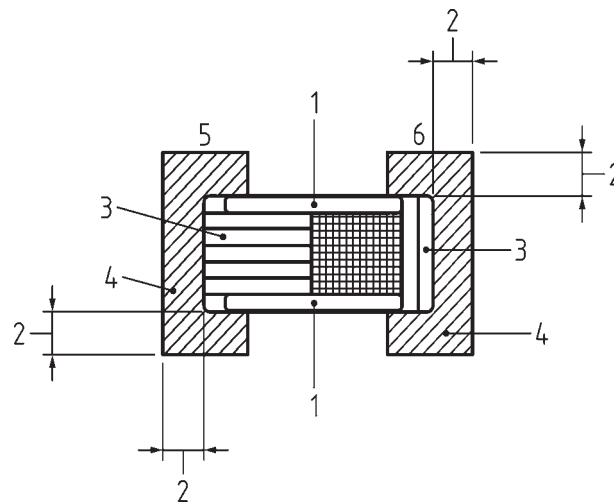

c) Up and over slide

Key

- | | | | |
|---|----------------|---|-------------|
| 1 | walled side | 4 | impact area |
| 2 | at least 1,2 m | 5 | exit |
| 3 | open side | 6 | entrance |

Figure 7 — Impact area
(standards.iteh.ai)

Anchorage points in impact areas shall be avoided if possible, but where necessary, anchorage points shall be connected to the bottom perimeter edge or seam of the inflatable and shall extend as short a distance as practicable from the inflatable (see Figure 8).

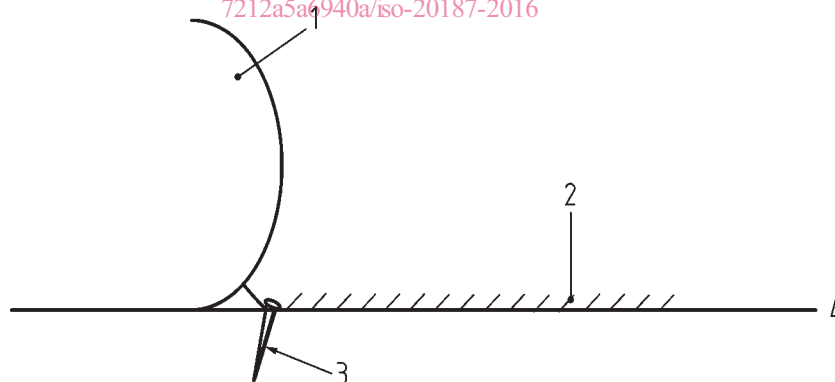

Key

- | | |
|---|---|
| 1 | side of inflatable |
| 2 | impact area |
| 3 | anchorage stake as close as practicable to the side of the inflatable |
| 4 | ground level |

Figure 8 — Anchorage in an impact area

Totally enclosed inflatables shall have signs indicating exits which shall be visible in all circumstances. When designed for more than 15 users, there shall be more than one exit and users shall never be more than 5 m from an exit.