



Designation: D5265 – 03 (Reapproved 2009)

## Standard Test Method for Bridge Impact Testing<sup>1</sup>

This standard is issued under the fixed designation D5265; the number immediately following the designation indicates the year of original adoption or, in the case of revision, the year of last revision. A number in parentheses indicates the year of last reapproval. A superscript epsilon ( $\epsilon$ ) indicates an editorial change since the last revision or reapproval.

### 1. Scope

1.1 This test method is intended to determine the capability of a long package with a narrow cross-section to resist impact near its center when the package is supported only at its ends. This test method allows the user to select from two test options: Option A employs the use of a free-fall drop tester (see Exhibit B), and Option B employs the use of simulated mechanical impact testing equipment (SMITE; see Exhibit A). The two optional procedures are designed to impart the same amount of kinetic energy at impact; therefore, each procedure yields equal damage-producing potential.

1.2 The values stated in SI units are to be regarded as the standard. The values given in parentheses are for information only.

1.3 *This standard does not purport to address all of the safety problems, if any, associated with its use. It is the responsibility of the user of this standard to establish appropriate safety and health practices and determine the applicability of regulatory limitations prior to use.*

### 2. Referenced Documents

#### 2.1 ASTM Standards:<sup>2</sup>

- D644 Test Method for Moisture Content of Paper and Paperboard by Oven Drying
- D685 Practice for Conditioning Paper and Paper Products for Testing
- D996 Terminology of Packaging and Distribution Environments
- D4332 Practice for Conditioning Containers, Packages, or Packaging Components for Testing
- E122 Practice for Calculating Sample Size to Estimate, With Specified Precision, the Average for a Characteristic of a Lot or Process

<sup>1</sup> This test method is under the jurisdiction of ASTM Committee D10 on Packaging and is the direct responsibility of Subcommittee D10.22 on Physical Test Methods.

Current edition approved March 1, 2009. Published March 2009. Originally approved in 1992. Last previous edition approved in 2003 as D5265 – 03 DOI: 10.1520/D5265-03R09.

<sup>2</sup> For referenced ASTM standards, visit the ASTM website, www.astm.org, or contact ASTM Customer Service at service@astm.org. For Annual Book of ASTM Standards volume information, refer to the standard's Document Summary page on the ASTM website.

### 3. Terminology

3.1 *Definitions*—The terms and definitions used in this test method may be found in Terminology D996.

3.2 *Definitions of Terms Specific to This Standard:*

3.2.1 *elongate package*—a package that is long in proportion to width and thickness, with lengths at least three times their width or height.

### 4. Significance and Use

4.1 Materials shipped in long, narrow packages, with lengths at least three times their width or height, are liable to damage as a result of impact near their midpoint when only the ends are supported. This type of damage can occur during the shipment of packaging of mixed dimensions. It is particularly prevalent during conveyer line transport and sortation. This test method provides a means of determining resistance to such damage.

### 5. Apparatus

5.1 *Option A—Free-Fall Drop Tester*, conforming to the conditions specified in 10.2.1 (see Fig. 1).

5.1.1 *Impactor*, composed of a dense hardwood, with a mass of  $5.7 \pm 0.2$  kg<sub>w</sub> ( $12.54 \pm 0.4$  lb), length of approximately 610 mm (24 in.), and width of 178 mm (7 in.). The depth can be adjusted to obtain the desired weight as stated above. The long edges of the impactor shall be rounded to a radius of  $6 \pm 2$  mm ( $\frac{1}{4} \pm \frac{1}{16}$  in.).

NOTE 1—If a lighter wood is used, the depth can be adjusted to achieve the correct mass.

5.1.2 *Support Blocks*, made from hardwood, nominal 150 by 150 mm (6 by 6 in.), long enough to support the full width of the largest package to be tested.

5.2 *Option B—Commercial SMITE Tester*, using a guided impactor and velocity meter to calculate the theoretical free-fall drop of the missile (see Fig. 2).

5.2.1 *SMITE Tester Impactor (missile)*, fabricated in a U-shape cross-section from a steel flat plate, with a mass of  $22.68 \pm 0.2$  kg<sub>w</sub> ( $50 \pm 0.4$  lb) and length of approximately 760 mm (30 in.). The long edges of the missile shall be rounded to a radius of  $6 \pm 2$  mm ( $\frac{1}{4} \pm \frac{1}{16}$  in.).

NOTE 2—The standard SMITE tester is equipped with a variety of interchangeable missiles, providing impact options ranging from flat drop,

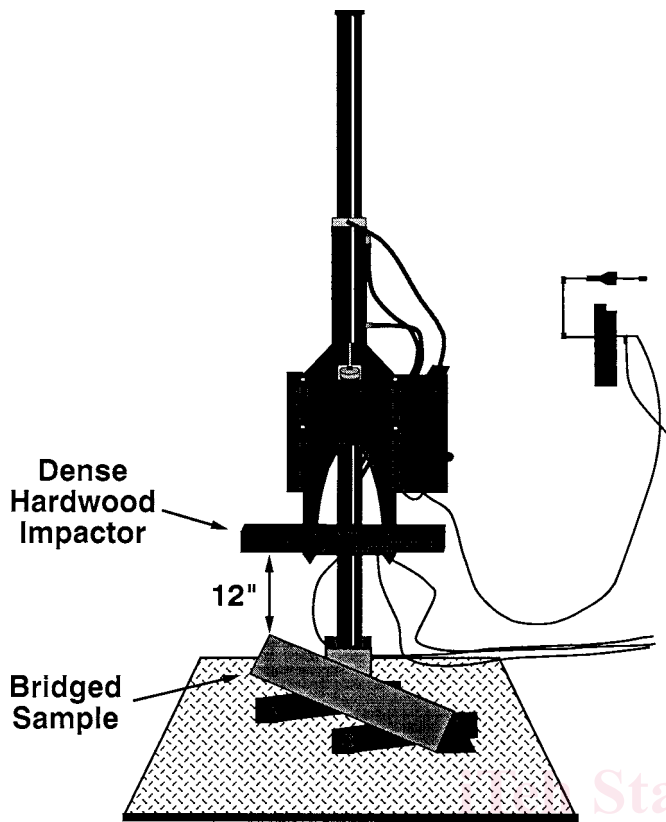

FIG. 1 Vertical Drop Tester

5.2.2 *Support Blocks*, made from dense hardwood, nominal 150 by 150 mm (6 by 6 in.), long enough to support the full width of the largest package to be tested.

## 6. Sampling

6.1 The test specimens and number of samples shall be chosen to permit an adequate determination of representative performance. For large production runs, lot sampling for quality control in accordance with Practice E122 is advised.

6.2 In the absence of any sampling plan, at least three representative specimens should be selected for performance evaluation.

## 7. Test Specimens

7.1 When the protective capability of a package is to be evaluated, it is preferable to pack the package with the actual contents for which it was designed (Note 3). When the capability of a box to withstand rough handling is to be evaluated, pack the container with either the actual contents or a load simulating the contents. Regardless of which procedure is used, close the container in the same manner that will be used in preparing it for shipment.

NOTE 3—Where the use of actual contents is not feasible because of excessive cost or danger, a dummy load simulating the contents with respect to dimensions, center of gravity, moment of inertia, density, flow characteristics, etc. shall be used.

7.2 When comparing the performance of various elongated package designs, it is preferable to test empty erected cartons, which are closed and sealed in the same manner that will be used in preparing it for shipment.

7.3 Close and seal the container in the normal manner. Dry and age sufficiently so that any adhesive, protective coatings, sealing tape, etc. will have reached their final normal condition.

## 8. Conditioning

8.1 Depending on the purpose of the tests, packages may be conditioned prior to the bridge impact test by either a different physical test, water immersion, exposure to water spray, or exposure to standard or other fixed conditions of air temperature or humidity.

8.2 Unless otherwise specified, fiberboard packages shall be conditioned in accordance with Method D685 or Practice D4332. Other packages shall be conditioned in accordance with Practice D4332.

8.3 The moisture content of paperboard and fiberboard packages should be determined in accordance with Test Method D644.

## 9. Acceptance Criteria

9.1 Acceptance criteria must be established prior to testing and should consider the required condition of the product upon receipt. The organizations conducting the test may choose any acceptance criteria suitable for their purpose. It is advisable to compare the type and quantity of damage that occurred to the test specimens with the damage that occurs during actual distribution and handling, or with the test results of similar containers whose shipping history is known.

9.2 In many cases, the acceptance criteria can be one of the following:

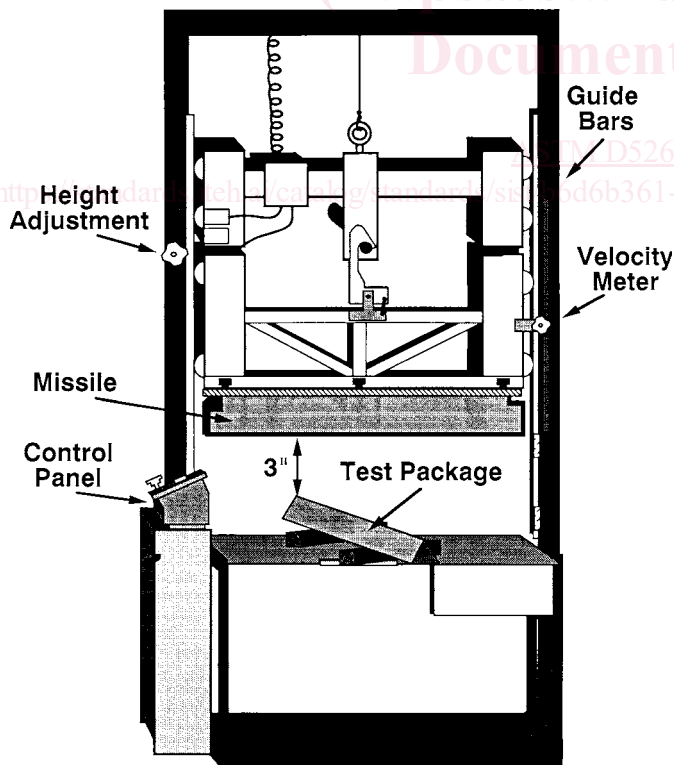

FIG. 2 Simulated Mechanical Impact Testing Equipment (SMITE)

angle edge drop, half round, half ball, and corner. The total missile assembly, regardless of which face is used, will weigh 22.68 kg (50 lb). Knowing this, the mass of a SMITE tester is always 22.68 kg.