



Designation: D 5656 – 01

Standard Test Method for Thick-Adherend Metal Lap-Shear Joints for Determination of the Stress-Strain Behavior of Adhesives in Shear by Tension Loading¹

This standard is issued under the fixed designation D 5656; the number immediately following the designation indicates the year of original adoption or, in the case of revision, the year of last revision. A number in parentheses indicates the year of last reapproval. A superscript epsilon (ϵ) indicates an editorial change since the last revision or reapproval.

1. Scope

1.1 This test method covers the preparation and testing of thick-adherend lap-shear samples for the determination of the stress-strain behavior of adhesives.

1.2 This test method covers data reduction and analysis of stress-strain curves obtained using thick-adherend lap-shear samples.

1.3 The values stated in SI units are to be regarded as the standard. The inch-pound units in parentheses are for information only.

1.4 *This standard does not purport to address all of the safety concerns, if any, associated with its use. It is the responsibility of the user of this standard to establish appropriate safety and health practices and determine the applicability of regulatory limitations prior to use.* Specific precautionary statements are given in 7.3.

2. Referenced Documents

2.1 *ASTM Standards:*

D 907 Terminology of Adhesives²

D 2651 Guide for Preparation of Metal Surfaces for Adhesive Bonding²

E 4 Practices for Force Verification of Testing Machines³

3. Terminology

3.1 *Definitions:*

3.1.1 Many terms in this test method are defined in Terminology D 907.

3.2 *Definitions of Terms Specific to This Standard:*

3.2.1 *knee*—inflection point on a load-deflection curve; the point at which plastic yielding of the adhesive begins to dominate the deformation response of the load-deflection curve.

3.2.2 *panel*—two plates of a rigid material having the same dimensions that are adhesively bonded together on one face such that the thickness of the panel is approximately twice the thickness of each individual plate.

4. Summary of Test Method

4.1 This test method consists of testing thick-adherend lap-shear samples whereby a tensile load is applied to the sample but the adhesive is placed in shear. Since the adherends used are thick and rigid, peel forces are minimized and the shear stress-strain properties of the adhesive are obtained.

NOTE 1—The peel forces generated during testing are a function of the bending deformation in the adherends. Greater adherend stiffness results in less bending and smaller peel forces.

5. Significance and Use

5.1 This test method can be used to determine the stress-strain properties of an adhesive in shear and to establish the proportional-limit of the stress-strain relationship. This data may be useful for the design and analysis of adhesively bonded joints.

5.2 This test method is not intended to determine adhesion characteristics of an adhesive to a particular substrate; rather this test method is intended to characterize the adhesive properties that may be relevant for design considerations.

5.3 This test method has been developed and applied using bonded aluminum adherends. At this time no assumptions regarding the validity of this test method with non-aluminum adherends can be made.

6. Apparatus

6.1 Testing machine conforming to the requirements of Practices E 4. Select the testing machine so that the breaking load of the specimens falls between 15 and 85 % of the full-scale capacity. Ensure that the machine is capable of maintaining a rate of loading of 2455 N (550 lbf)/min, or, if the rate is dependent on cross-head motion, set the machine to approach this rate of loading. Use a suitable pair of self-aligning grips to hold the specimen. Ensure that the grips and attachments are so constructed that they will move into alignment with the test specimen as soon as the load is applied,

¹ This test method is under the jurisdiction of ASTM Committee D14 on Adhesives and is the direct responsibility of Subcommittee D14.80 on Metal Bonding Adhesives.

Current edition approved Oct. 10, 2001. Published December 2001. Originally published as D 5656 - 95. Last previous edition D 5656 - 95(2000).

² *Annual Book of ASTM Standards*, Vol 15.06.

³ *Annual Book of ASTM Standards*, Vol 03.01.

so that the long axis of the test specimen will coincide with the direction of the applied pull through the center line of the grip assembly.

NOTE 2—The cross-head speed setting required to approach the specified loading rate is dependent on the modulus of the adherends and the adhesive being evaluated.

6.2 Use two three-point displacement sensors/(linear variable differential transformers) extensometers with the capability of measuring displacements in the adhesive bond overlap area, and a sensitivity sufficient to measure displacements with an accuracy of 1 part/1000.

7. Sample Preparation

7.1 Suitably prepare the bonding surfaces of two 229 by 229-mm (9 by 9-in.) by 9.5 ± 0.05-mm (0.375 ± 0.002-in.) rigid adherends which do not deflect during testing, such as 2024-T3 aluminum, for the adhesive being used. For aluminum, solvent degreasing and acid etching, such as Method G of Guide D 2651, are recommended for removing the oxide coating from the aluminum surfaces to be bonded.

7.2 Apply the adhesive in a uniform layer to one face of one of the adherend plates. In the case of paste adhesives and unsupported film adhesives, metal wires or shims may be used to control the bondline thickness. In this case, take care to ensure that the shims are outside of the lap area or are located in the trim region around the panel perimeter so that they do not affect the test results. Place the other adherend plate on top of the adhesive-coated plate in accordance with Fig. 1. To achieve the desired adhesive thickness, apply sufficient pressure to cause the adhesive to flow between the plates such that the plates are in contact with the shims if they are being used. Cure the adhesive in accordance with the manufacturer’s recommended practices for the adhesive being tested.

NOTE 3—The use of glass beads in the adhesive to control the bondline thickness is not recommended, since their use will have an effect on the calculated values of modulus, strain, and strength.

7.3 After cure, saw-cut 25.4-mm (1.0-in.) wide test samples from the bonded panel, or if machined edges are preferred saw-cut the samples to 27.5-mm widths and machine the saw cut edges to a sample width of 25.4 mm (1.0 in.). Use an end mill to machine notches through the glue line in accordance with Fig. 2. Drill holes for inserting support pins and steel bushings for testing in accordance with Fig. 2. (**Warning**—Exercise caution during machining of the notches to minimize the buildup of stresses and thermal degradation of the adhesive in this region.)

7.4 Using a vernier caliper or other suitable measuring device, measure the width of the overlap area to the nearest 0.003 mm (0.001 in.) for each test sample.

7.5 Using an optical comparator or other suitable measuring device, measure the overlap length to the nearest 0.003 mm (0.001 in.) for each test sample.

7.6 Using an optical comparator or other suitable measuring device, measure the adhesive thickness in the overlap region to the nearest 0.0003 mm (0.0001 in.) for each test sample.

8. Calibration of Extensometers

8.1 Connect the extensometers to an amplifier with two signal inputs and one signal output which is the average of the two input signals. Connect the amplifier output to a strip-chart recorder that will be used during testing. Allow sufficient time for the amplifier to warm up to minimize signal drift.

8.2 Using a micrometer gage or similar device, adjust the amplifier gain such that 0.0254 mm (0.001 in.) of extensometer displacement is equal to 50.8 mm (2.0 in.) of chart travel.

8.3 Repeat the procedure for the remaining extensometer.

9. Conditioning

9.1 The accuracy of the results of strength tests of adhesive bonds depends on the conditions under which the bonding process is carried out. Unless otherwise agreed upon between the manufacturer and the purchaser, use the bonding conditions prescribed by the manufacturer of the adhesive. In order to ensure that complete information is available to the individual conducting the tests, obtain numerical values and other specific information from the manufacturer of the adhesive for each of the following variables:

9.2 Procedure for preparation of surfaces prior to application of the adhesive, the cleaning and drying of adherend surfaces, and special surface treatments, such as sanding, that are not specifically limited by the pertinent test method,

9.2.1 Complete mixing directions for the adhesive,

9.2.2 Conditions for application of the adhesive, including the rate of spread or thickness of film, number of coats to be applied, whether to be applied to one or both surfaces, and the conditions of drying where more than one coat is required,

9.2.3 Assembly conditions before application of pressure, including the room temperature, relative humidity, and length of time,

9.2.4 Curing conditions, including the amount of pressure to be applied, the length of time under pressure, method of applying pressure (pressure bag, press platens, etc.), heat-up rate, and the temperature of the assembly when under pressure.

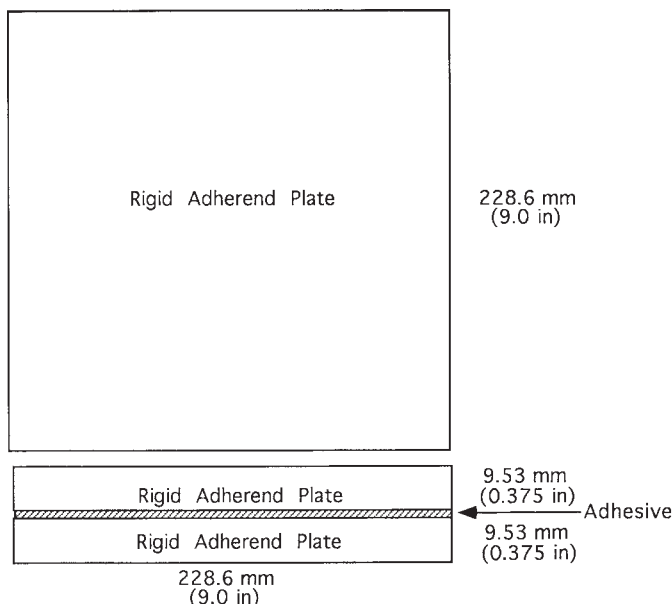
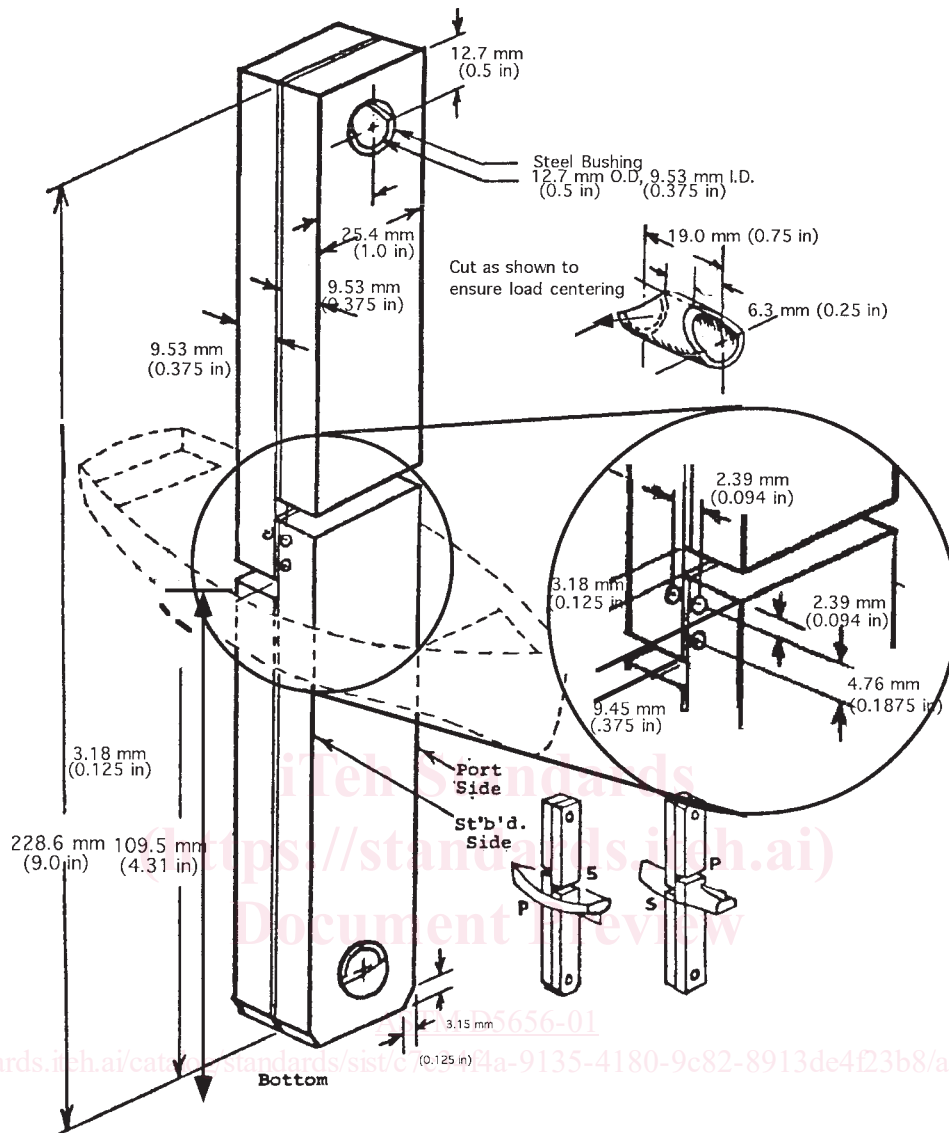

FIG. 1 Bonded Adherend Plates



NOTE 1—Asymmetry obviates “left-right” convention. Ship terms retain identity of test site when specimen is rotated or inverted.

FIG. 2 Thick Adherend Lap Shear Test Specimen

Ensure that it is stated whether this temperature is that of the bondline or of the atmosphere at which the assembly is to be maintained,

9.2.5 Conditioning procedure before testing, unless a standard procedure is specified, including the length of time, temperature, and relative humidity.

9.3 A range may be prescribed for any variable by the manufacturer of the adhesive if it can be assumed by the test operator that any arbitrarily chosen value within such a range or any combination of such values for several variables will be acceptable to both the manufacturer and the purchaser of the adhesive.

10. Procedure

10.1 Connect two extensometers to the signal amplifier and the averaged signal output from the amplifier to the strip-chart recorder. Allow sufficient time for the amplifier to warm up to minimize signal drift.

10.2 Set the chart range such that the expected output signals during testing from the extensometer is between 15 and 85 % of full scale.

10.3 Using a solid bar of adherend material machined to the same overall dimensions and geometry as the test sample, attach one of the extensometers to each edge of the bar, in accordance with Fig. 3.

10.4 Mount the bar in the test machine by placing a steel bushing through each of the drilled holes of the solid bar and inserting steel pins through the bushings and clevises attached to the test machine. Adjust the cross-head position of the test machine to zero, the initial load on the specimen. Load the bar to 4017 N (900 lbf) at a rate of 2455 N/min (550 lbf/min). Repeat the loading six times and record the load versus displacement for each loading.