



# SLOVENSKI STANDARD

## SIST EN 14488-3:2024

01-februar-2024

Nadomešča:  
SIST EN 14488-3:2006

---

**Preskušanje brizganega betona - 3. del: Upogibna trdnost (prvi vrh, končna in preostala) z vlakni armiranih prizmatičnih preskušancev**

Testing sprayed concrete - Part 3: Flexural strengths (first peak, ultimate and residual) of fibre reinforced beam specimens

Prüfung von Spritzbeton - Teil 3: Biegefestigkeiten (Erstriss-, Biegezug- und Restfestigkeit) von faserverstärkten balkenförmigen Betonprüfkörpern

Essais pour béton projeté - Partie 3 : Résistances à la flexion (au premier pic, ultime et résiduelle) d'éprouvettes parallélépipédiques en béton renforcé par des fibres

**Ta slovenski standard je istoveten z: EN 14488-3:2023**

<https://standards.iteh.ai/catalog/standards/sist/53a1db92-c728-403e-abc0-6c520f7371d5/sist-en-14488-3-2024>

---

**ICS:**

91.100.30	Beton in betonski izdelki	Concrete and concrete products
-----------	---------------------------	--------------------------------

**SIST EN 14488-3:2024**

**en,fr,de**



EUROPEAN STANDARD

EN 14488-3

NORME EUROPÉENNE

EUROPÄISCHE NORM

November 2023

ICS 91.100.30

Supersedes EN 14488-3:2006

English Version

## Testing sprayed concrete - Part 3: Flexural strengths (first peak, ultimate and residual) of fibre reinforced beam specimens

Essais pour béton projeté - Partie 3 : Résistances à la flexion (au premier pic, ultime et résiduelle) d'éprouvettes parallélépipédiques en béton renforcé par des fibres

Prüfung von Spritzbeton - Teil 3: Biegefestigkeiten (Erstriss-, Biegezug- und Restfestigkeit) von faserverstärkten balkenförmigen Betonprüfkörpern

This European Standard was approved by CEN on 30 July 2023.

CEN members are bound to comply with the CEN/CENELEC Internal Regulations which stipulate the conditions for giving this European Standard the status of a national standard without any alteration. Up-to-date lists and bibliographical references concerning such national standards may be obtained on application to the CEN-CENELEC Management Centre or to any CEN member.

This European Standard exists in three official versions (English, French, German). A version in any other language made by translation under the responsibility of a CEN member into its own language and notified to the CEN-CENELEC Management Centre has the same status as the official versions.

CEN members are the national standards bodies of Austria, Belgium, Bulgaria, Croatia, Cyprus, Czech Republic, Denmark, Estonia, Finland, France, Germany, Greece, Hungary, Iceland, Ireland, Italy, Latvia, Lithuania, Luxembourg, Malta, Netherlands, Norway, Poland, Portugal, Republic of North Macedonia, Romania, Serbia, Slovakia, Slovenia, Spain, Sweden, Switzerland, Türkiye and United Kingdom.

<https://standards.iteh.ai>  
SIST EN 14488-3:2024

<https://standards.iteh.ai/catalog/standards/sist/53a1db92-c728-403e-abc0-6c520f7371d5/sist-en-14488-3-2024>



EUROPEAN COMMITTEE FOR STANDARDIZATION  
COMITÉ EUROPÉEN DE NORMALISATION  
EUROPÄISCHES KOMITEE FÜR NORMUNG

CEN-CENELEC Management Centre: Rue de la Science 23, B-1040 Brussels

## Contents

	Page
European foreword.....	3
Introduction .....	4
<b>1 Scope.....</b>	<b>5</b>
<b>2 Normative references.....</b>	<b>5</b>
<b>3 Terms and definitions .....</b>	<b>5</b>
<b>4 Symbols and abbreviated terms .....</b>	<b>6</b>
4.1 Symbols.....	6
4.2 Abbreviations .....	7
<b>5 Principle .....</b>	<b>7</b>
<b>6 Method A: Four point bending test on beam .....</b>	<b>7</b>
6.1 Apparatus.....	7
6.1.1 Testing machine .....	7
6.1.2 Force application.....	8
6.1.3 Deflection measurement and control.....	9
6.2 Test specimen.....	9
6.2.1 General.....	9
6.2.2 Adjustment of test specimens.....	10
6.3 Procedures.....	10
6.3.1 Preparation and positioning of specimens.....	10
6.3.2 Loading.....	11
6.4 Expression of results.....	11
6.4.1 First peak and ultimate flexural strengths .....	11
6.4.2 Residual flexural strengths.....	12
6.5 Test report.....	13
6.6 Accuracy .....	13
<b>7 Method B: Three point bending test on square panel with notch .....</b>	<b>14</b>
7.1 Apparatus.....	14
7.1.1 Testing machine .....	14
7.2 Test specimens.....	15
7.2.1 Shape and size of test specimens.....	15
7.2.2 Manufacture and curing of test specimens .....	15
7.2.3 Notching of test specimens .....	15
7.3 Testing procedure.....	16
7.3.1 Preparation and positioning of test specimens .....	16
7.3.2 Bending test .....	19
7.4 Expression of results.....	19
7.4.1 Equivalence between CMOD and deflection .....	19
7.4.2 Limit of proportionality.....	20
7.4.3 Residual flexural tensile strength .....	20
7.5 Test report.....	22
7.6 Precision.....	22

## European foreword

This document (EN 14488-3:2023) has been prepared by Technical Committee CEN/TC 104 “Concrete and related products”, the secretariat of which is held by SN.

This European Standard shall be given the status of a national standard, either by publication of an identical text or by endorsement, at the latest by May 2024 and conflicting national standards shall be withdrawn at the latest by May 2024.

Attention is drawn to the possibility that some of the elements of this document may be the subject of patent rights. CEN shall not be held responsible for identifying any or all such patent rights.

This document supersedes EN 14488-3:2006.

EN 14488-3:2023 includes the following significant change in comparison with EN 14488-3:2006:

- Introduction of testing Method B, the three point bending test on spray square panel with notch to determine the flexural residual strength. The residual strength method can be prescribed when the concrete characteristics are used in a structural design model. This is especially useful for permanent sprayed concrete linings.

This document is part of a series concerned with testing sprayed concrete.

The EN 14488 series, *Testing sprayed concrete*, includes the following parts:

- *Part 1: Sampling fresh and hardened concrete*
- *Part 2: Compressive strength of young sprayed concrete*
- *Part 3: Flexural strengths (first peak, ultimate and residual) of fibre reinforced beam specimens*
- *Part 4: Bond strength of cores by direct tension*
- *Part 5: Determination of energy absorption capacity of fibre reinforced slab specimens*
- *Part 6: Thickness of concrete on a substrate*
- *Part 7: Fibre content of fibre reinforced concrete*

Any feedback and questions on this document should be directed to the users’ national standards body. A complete listing of these bodies can be found on the CEN website.

According to the CEN-CENELEC Internal Regulations, the national standards organizations of the following countries are bound to implement this European Standard: Austria, Belgium, Bulgaria, Croatia, Cyprus, Czech Republic, Denmark, Estonia, Finland, France, Germany, Greece, Hungary, Iceland, Ireland, Italy, Latvia, Lithuania, Luxembourg, Malta, Netherlands, Norway, Poland, Portugal, Republic of North Macedonia, Romania, Serbia, Slovakia, Slovenia, Spain, Sweden, Switzerland, Türkiye and the United Kingdom.

**EN 14488-3:2023 (E)****Introduction**

Classification of residual flexural strength of fibre reinforced sprayed concrete is made by specification of a strength level at a certain deformation range.

This could be done using the four point bending test described in Method A or using the three point bending test on square notched panel described in Method B of this document.

Methods A and B can be used for metallic fibres, synthetic or other fibres, or a combination of fibre types.

**iTeh Standards**  
**(<https://standards.iteh.ai>)**  
**Document Preview**

[SIST EN 14488-3:2024](https://standards.iteh.ai/catalog/standards/sist/53a1db92-c728-403e-abc0-6c520f7371d5/sist-en-14488-3-2024)

<https://standards.iteh.ai/catalog/standards/sist/53a1db92-c728-403e-abc0-6c520f7371d5/sist-en-14488-3-2024>

## 1 Scope

This document specifies methods (Methods A and B) for the determination of the first peak, ultimate and residual strength of specimens of hardened sprayed concrete.

## 2 Normative references

The following documents are referred to in the text in such a way that some or all of their content constitutes requirements of this document. For dated references, only the edition cited applies. For undated references, the latest edition of the referenced document (including any amendments) applies.

EN 12390-1, *Testing hardened concrete — Part 1: Shape, dimensions and other requirements for specimens and moulds*

EN 12390-2, *Testing hardened concrete — Part 2: Making and curing specimens for strength tests*

EN 12390-4, *Testing hardened concrete — Part 4: Compressive strength — Specification for testing machines*

EN 14487-1, *Sprayed concrete — Part 1: Definitions, specifications and conformity*

EN 14488-1, *Testing sprayed concrete — Sampling fresh and hardened concrete*

## 3 Terms and definitions

For the purposes of this document, the following terms and definitions apply.

ISO and IEC maintain terminology databases for use in standardization at the following addresses:

- IEC Electropedia: available at <https://www.electropedia.org/>
- ISO Online browsing platform: available at <https://www.iso.org/obp/>

### 3.1

#### **crack mouth opening displacement**

linear displacement measured by a transducer installed on a specimen subjected to a central line load  $F$

### 3.2

#### **deflection**

linear displacement measured by a transducer installed on a specimen subjected to a central line load  $F$

### 3.3

#### **limit of proportionality**

stress at the tip of the notch which is assumed to be exerted, in the case of a linear stress distribution, in an uncracked section at mid-span of a prism subjected to a centred load  $F_L$  (Method A) or  $F_{LS}$  (Method B)

### 3.4

#### **residual flexural tensile strength according to Method A**

residual strength on the beam calculated from the minimum load on the flexural stress/deflection curve between 0,5 mm and 1 mm, 2 mm and 4 mm

### 3.5

#### **residual flexural tensile strength according to Method B**

fictitious stress at the tip of the notch which is assumed to act in an uncracked mid-span section, with linear stress distribution, of a plate subjected to the central line load  $F_j$  corresponding to  $CMOD_j$  where  $CMOD_j > CMOD_{F_L}$  or to  $\delta_j$  where  $\delta_j > \delta_{F_L}$  ( $j = 1,2,3,4$ )

**EN 14488-3:2023 (E)****4 Symbols and abbreviated terms****4.1 Symbols**

For the purposes of this document, the following symbols apply.

$CMOD_{F_{LS}}$	CMOD at LOP
$CMOD_{j_s}$	value of CMOD, $j = 1, 2, 3$ or $4$
$F$	load
$F_{j_s}$	load value, $j = 1, 2, 3$ or $4$
$F_L$	load at LOP (according to Method A)
$F_{L_S}$	load at LOP (according to Method B)
$L$	length of test specimen
$M$	bending moment
$M_{j_s}$	bending moment value, $j = 1, 2, 3$ or $4$
$M_{L_S}$	bending moment corresponding to the load at LOP
$b$	width of test specimen
$f_{R,j}$	residual flexural strengths determined from sawn beams according to Method A, where $j = 1, 2$ or $4$
$f_{R,j_s}$	residual flexural tensile strengths determined from panels according to Method B, where $j = 1, 2, 3$ or $4$
$f_{ct,L_s}^f$	LOP
$F_{fp}$	first peak load
$F_{ult}$	maximum load
$h_{sp}$	is the distance, in mm, between the tip of the notch and the top of the beam (equal as the unnotched height).
$l$	length of span
$x$	width of notch
$y$	distance between bottom of test specimen and axis of displacement transducer
$\delta$	deflection
$\delta_{F_{L_S}}$	deflection at LOP
$\delta_{j_s}$	deflection value, $j = 1, 2, 3$ or $4$



## 4.2 Abbreviated terms

For the purposes of this document, the following abbreviated terms apply.

CMOD crack mouth opening displacement

LOP limit of proportionality

## 5 Principle

Specimens are subject to a bending moment by the application of load through upper and lower rollers. The first peak, maximum and residual loads sustained are recorded and the corresponding flexural strengths calculated.

A fibre reinforced specimen, sawn from a test panel in accordance with EN 14488-1 is subject to a bending moment by the application of load through upper and lower rollers under deflection control to obtain its load/deflection response (the latter exclusive of non-bending deformations). The first peak, ultimate and residual flexural strengths (Method A) or the limit of proportionality and the residual flexural tensile strength (Method B) are determined from the load/deflection curve.

## 6 Method A: Four point bending test on beam

### 6.1 Apparatus

#### 6.1.1 Testing machine

The test shall be carried out using a test machine in accordance with EN 12390-4 for all articles relevant for bending tests.

The stiffness and control system of the testing machine shall be such that the test can be deflection controlled.

The stiffness of the load system (including frame, load cell, loading block and support frame) shall be at least 200 kN/mm.

A steel or aluminium yoke (Figure 1).

A calibrated electronic transducer with a resolution of at least 0,02 mm.

An electronic data logger or XY plotter.

## EN 14488-3:2023 (E)

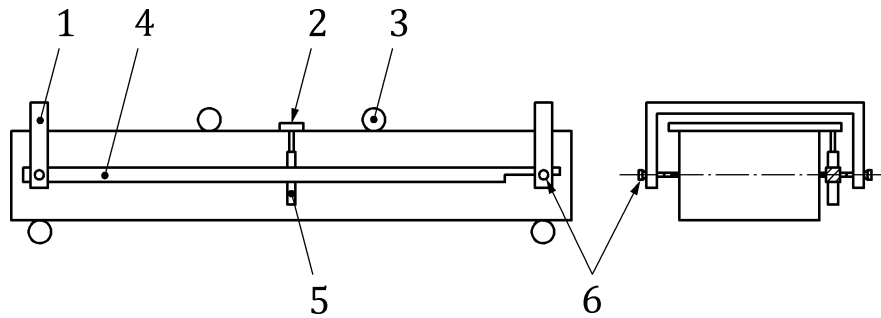
**Key**

- 1 clamp
- 2 reference bar (clamped or glued)
- 3 loading roller
- 4 yoke
- 5 transducer
- 6 locating screw

A yoke/transducer may be fixed at each side of the beam, instead of at only one as it is represented in the section of the beam.

**Figure 1 — Arrangement of yoke for bending deflection measurement**

### 6.1.2 Force application

The device for applying loads (see Figure 2) shall consist of:

- two supporting rollers;
- two upper rollers carried by an articulated cross member, which divides the load applied by the machine equally between the two rollers.

All rollers shall be manufactured from steel and shall have a circular cross-section with a diameter of 20 mm to 40 mm. They shall be at least 10 mm longer than the width of the test specimen.

Three rollers, including the two upper ones, shall be capable of rotating freely around their axes and of being inclined in a plane normal to the longitudinal axis of the test specimen.

The distance,  $l$ , between the outer rollers (i.e. the span) shall be equal to  $6d$ , where  $d$  is 75 mm. The distance between the inner rollers shall be equal to  $2d$ . The inner rollers shall be equally spaced between the outer rollers as shown in Figure 2. All rollers shall be adjusted to the positions illustrated in Figure 2 to an accuracy of  $\pm 2,0$  mm.