



Designation: ~~D4675-06~~<sup>e2</sup> Designation: D 4675 – 09

## Standard Guide for Selection and Use of Flat Strapping Materials<sup>1</sup>

This standard is issued under the fixed designation D 4675; the number immediately following the designation indicates the year of original adoption or, in the case of revision, the year of last revision. A number in parentheses indicates the year of last reapproval. A superscript epsilon ( $\epsilon$ ) indicates an editorial change since the last revision or reapproval.

*This standard has been approved for use by agencies of the Department of Defense.*

---

~~<sup>1</sup>Note—The term “polyolefin” was replaced with “polypropylene” throughout editorially in January 2007.~~

~~<sup>2</sup>Note—Section 2.2 was editorially corrected in December 2008.~~

---

### INTRODUCTION

This guide covers two common categories of strapping materials: flat carbon steel and nonmetallic strapping. Within each of these two broad categories, there are distinct types that lend themselves to particular applications to differing degrees.

The goal of this guide is to help the user focus on the desired elements of performance or service, and the unique properties of each strapping material in order to judge which of these strapping materials is best suited for the application. Contact your supplier for further information.

It is recognized that there are other materials (not covered) that may also offer acceptable solutions or may be used in conjunction with flat strapping. Also, examples of ancillary materials are shown in Fig. 1.

Strapping may be recyclable. Contact your supplier for further information.

### 1. Scope

1.1 This guide covers information on flat strapping materials (steel or nonmetallic) for the prospective user wanting initial guidance in selecting a strapping material and applied configuration for use in packaging (closing, reinforcing, baling, unitizing, or palletizing) and loading (load unitization and securement to transport vehicle) applications. The use applies to handling, securement, storage, and distribution systems.

1.2 Carrier associations have established certain packaging and loading requirements that in some cases specify a type of strap, the minimum size or strength, or both, and type of joint or seal, or both, that must be used for certain types of shipments or under certain conditions. Users should consult with their carriers initially to determine if there are applicable, published requirements. Individual carriers may establish their own requirements (see 2.2).

1.3 *Limitations*— This guide is not intended to give specific information as to how strapping must be used in any particular packaging or loading situation. Rather it is intended to be informational in nature and is offered as a starting point for testing. The need for thorough user testing is to be emphasized as is a review of pertinent regulations that can influence the selection of sizes, types, and possibly, application methods.

1.4 The sections in this guide appear in the following order:

---

<sup>1</sup> This guide is under the jurisdiction of ASTM Committee D10 on Packaging and is the direct responsibility of Subcommittee D10.25 on Palletizing and Unitizing of Loads.

Current edition approved Oct. 1, 2006. Published October 2006. Originally approved in 1987. Last previous edition approved in 2003 as D4675-03.

Current edition approved March 1, 2009. Published March 2009. Originally approved in 1987. Last previous edition approved in 2006 as D 4675 – 06 <sup>e2</sup>.

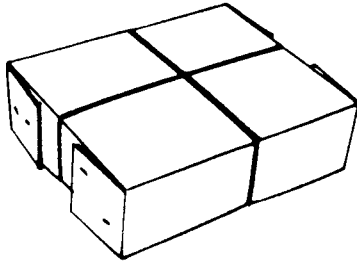

(a) Fiberboard Box Closure

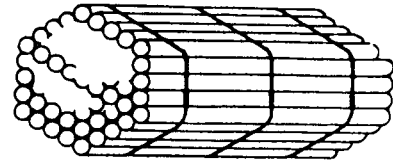

(b) Bundles of Tubing

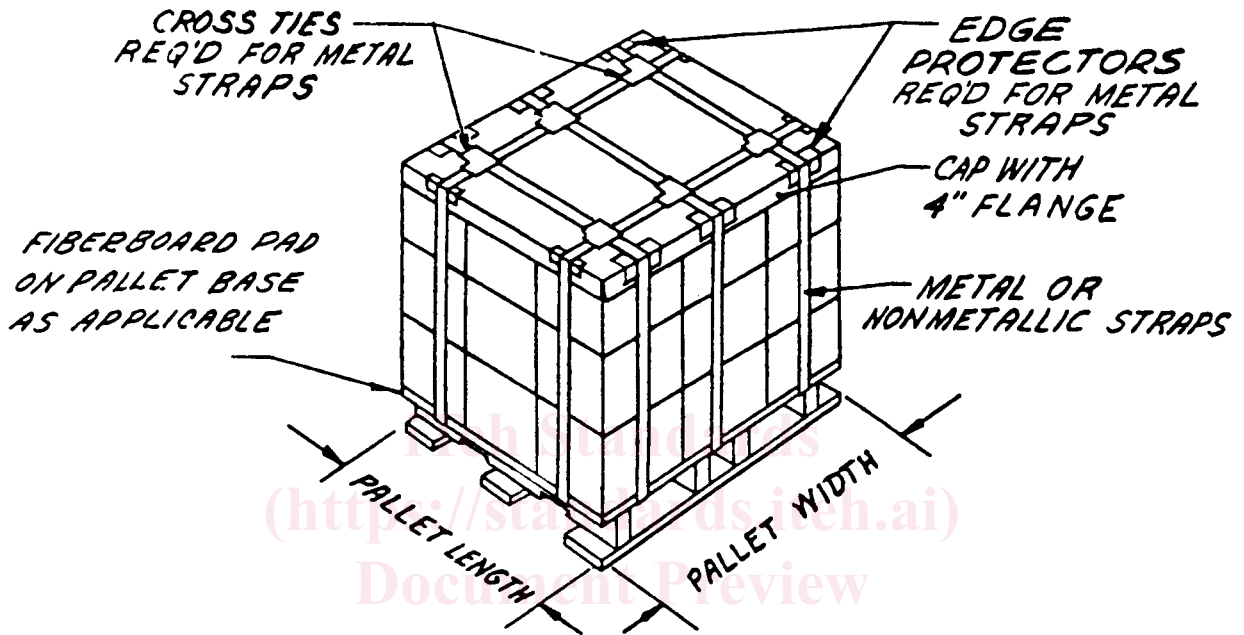

LOAD WITH CAP AND STRAPPING.

(c) Pallet

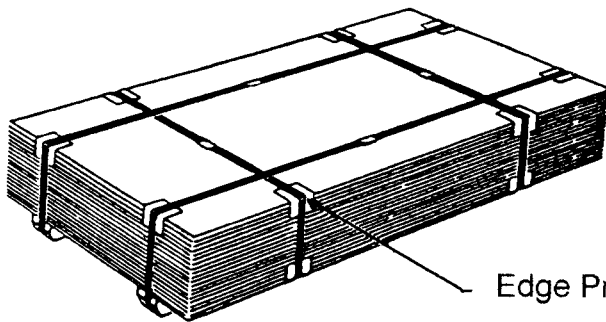

(d) Unitized Sheets

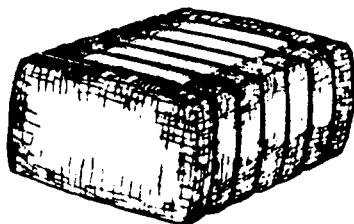

(e) Bales of Textile Fiber

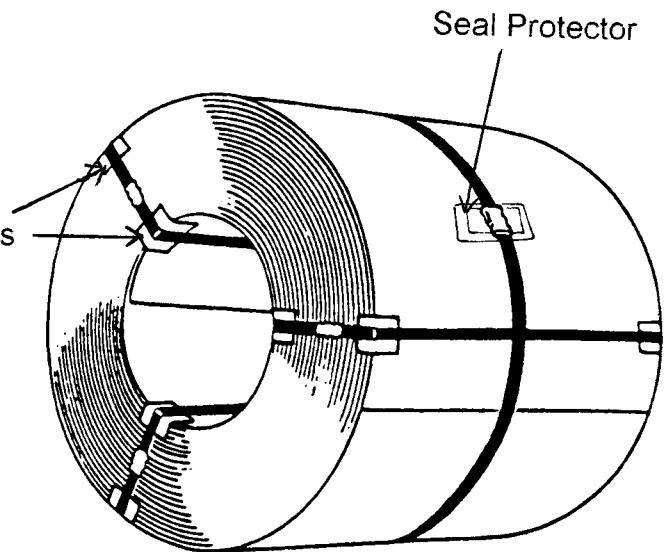

(f) Coils

FIG. 1 Applications for Steel and Nonmetallic Strapping

	Section
Scope	1
Referenced Documents	2
Terminology	3
Significance and Use	4
Safety Hazards	5
General Considerations:	
Properties of Strap Types	6
General Uses	7
Strap Tension	8
Packaging Design:	
Distribution	9
Package Configuration	10
Strap Selection	11
Joining Methods and Properties	
Joint Methods and Properties (except loop joint)	12
Loop Joint and Seal Properties	13
Coatings:	
Strap Coatings and Purposes	14
Application:	
Equipment for Strap Application	15
Strap Application	16
Testing and Evaluation:	
Testing and Developing Final Package Design	17
Evaluation of Strap Failure	18
Keywords	19
Supplementary Guideline	S1

1.5 The values stated in inch-pound units are to be regarded as the standard. The SI units given in parentheses are for information only.

1.5 The values stated in inch-pound units are to be regarded as standard. The values given in parentheses are mathematical conversions to SI units that are provided for information only and are not considered standard.

1.6 This standard does not purport to address all of the safety concerns, if any, associated with its use. It is the responsibility of the user of this standard to establish appropriate safety and health practices and determine the applicability of regulatory limitations prior to use. Specific safety hazard statements are given in Section 5 and Note 13.1 and 15.3.

## 2. Referenced Documents

### 2.1 ASTM Standards:<sup>2</sup>

- D 996 Terminology of Packaging and Distribution Environments
- D 3950 Specification for Strapping, Nonmetallic (and Joining Methods)
- D 3953 Specification for Strapping, Flat Steel and Seals
- D 4169 Practice for Performance Testing of Shipping Containers and Systems

### 2.2 Other Standards:

- Uniform Freight Classification Code, Rule 41, Section 9<sup>3</sup>
- National Motor Freight Classification 100-L, Item 222, Section 7<sup>4</sup>
- ISTA, International Safe Transit Association, Pre-Shipment Test Procedures<sup>5</sup>
- Association of American Railroads— Railing<sup>6</sup>

## 3. Terminology

3.1 *Definitions*— For general definitions of packaging and distribution environments, see Terminology D 996.

3.2 *Definitions of Terms Specific to This Standard:* The following refer to the characteristics and properties of strapping materials. These can be objectively measured to some extent and are used to rank the relative effectiveness of different strapping materials in different applications. The definitions given here are for the purposes of this guide only and do not necessarily reflect general usage or ASTM standard definitions. Some properties are common to both steel and nonmetallic strapping. Other properties are peculiar to nonmetallic only, or to steel only.

3.2.1 *break strength, n*—the longitudinal tensile force that must be applied to cause a strap to rupture. (See Specifications D 3950 and D 3953.)

3.2.2 *corner break strength, n*—the reduced break strength due to the strap being bent around an edge. (See Specification D 3953.)

<sup>2</sup> For referenced ASTM standards, visit the ASTM website, [www.astm.org](http://www.astm.org), or contact ASTM Customer Service at [service@astm.org](mailto:service@astm.org). For *Annual Book of ASTM Standards* volume information, refer to the standard's Document Summary page on the ASTM website.

<sup>3</sup> Available from National Railroad Freight Classification, available from Uniform Classification Committee, 222 South Riverside Plaza, Chicago, IL 60606.

<sup>4</sup> Available from National Motor Freight Traffic Association (NMFTA), 1001 N. Fairfax St., Alexandria, VA 22314, <http://www.nmfta.org>.

<sup>5</sup> Available from International Safe Transit Association (ISTA), 1400 Abbot Road, Suite 160, East Lansing, MI 48823-1900, <http://www.ista.org>.

<sup>6</sup> Available from Association of American Railroads—Railing, Association of American Railroads—Railing Highwoods Center, 7001 Weston Parkway, Suite 200, Cary, NC 27513.

3.2.3 *dead stretch (creep)*, *n*—permanent deformation, resulting from the application of tension over time.

3.2.4 *ductility in bending (resistance to “work hardening”)*, *n*—ductility is the opposite of “brittleness”. This quality is related to corner break strength and closely allied with strength and elongation in determining impact resistance. It is also important in tensioning applications requiring the strap to be bent double, and in loop joint applications. (Specification D 3953 contains test procedures and specifications.)

3.2.5 *elongation at break*, *n*—the increase in strapping length due to tensile load at the time of break. (See Specifications D 3950 and D 3953.)

3.2.6 *energy to break*, *n*—the maximum force required to break a strap as measured by the area under the stress-strain curve.

3.2.7 *environmental resistant properties (see Table 1)* :

3.2.8 *atmospheric contamination*, *n*—the presence of chemicals in the atmosphere which degrades strap properties. (See Section 14.)

3.2.9 *mechanism*, *n*—includes application, tool, tooling, tensioner, sealer, and power strap equipment.

3.2.10 *moisture sensitivity*, *n*—the degradation of properties caused by presence of moisture or moisture vapor.

3.2.11 *temperature sensitivity*, *n*—the deterioration of properties caused by high or low temperatures.

3.2.12 *ultraviolet light sensitivity*, *n*— the degradation of strapping caused by ultraviolet rays from sunlight or electric lamps.

3.2.13 *joint efficiencies*, *n*—joint strength divided by the minimum acceptable breaking strength of the strap, expressed as a percentage. (See Specifications D 3950 and D 3953 for minimum acceptable percentage values.)

3.2.14 *joint strength*, *n*—the highest longitudinal tensile force that must be applied to cause a strap joint to fail.

3.2.15 *notch sensitivity*, *n*—a measure of the ability of a strapping material to resist “nick or cut” propagation.

3.2.16 *settling tolerance*, *n*—the ability of a strap to remain taut when used to confine a settling unit load.

3.2.17 *shear plane*, *n*—a shear plane is the surface area between two contiguous items that will allow the items to slide relative to each other when a force is applied.

3.2.18 *tension transmission*, *n*—the ability of strapping to transmit tension around an edge.

3.2.19 *yield point*, *n*—when a strap is subjected to load beyond its elastic limit, the point at which a strap reaches permanent deformation or continues to deform without an increase in load.

#### 4. Significance and Use

4.1 This guide assists the user in selecting a strapping material and configuration for initial handling, transit, and storage tests. It describes general unit (load) types, strapping properties, unit-strapping interaction, weight considerations, unit shear planes, component frictional characteristics, and unit geometry.

#### 5. Safety Hazards

5.1 *Cutting Strap*— All working strapping is under tension when in use. Sudden release of this tension will produce a hazard when the loose ends snap free after being intentionally or accidentally cut, frayed, or otherwise released. Contents under restraint or the strap itself, or both, may spring toward operator when strap tension is suddenly released. *Cutting tensioned strap is hazardous*. Use caution and follow approved safety procedures.

5.1.1 When cutting a tensioned strap, always stand to one side of the strap being cut, pressing the strap against the package above the cutter.

5.2 Excessive tensioning may cause strap breakage. Always position yourself to one side of strap being tensioned. Never stand directly over or in front of a strap being tensioned.

5.3 Never operate the tool in such a manner that a hand could slip resulting in a loss of balance.

5.4 *Reuse*—Since mechanical properties of strapping may be altered by tensioning or during physical distribution cycles, the reuse of strapping is discouraged.

5.5 *Altering or Improper Use of Tensioners*—Do not extend length of handle on manual tensioner, nor exceed the manufacturer’s recommended maximum air pressure on pneumatic tensioners to gain increased strap tension. To do so could result

**TABLE 1 Strapping Preference as a Function of Handling Severity of Elements**

Type	Specification D 3953			Specification D 3950				
	Regular-Duty Steel	Regular-Duty High Strength Steel	Heavy-Duty Steel	Bonded Rayon Cord	Bonded or Woven Polyester Cord	Polypropylene Plastic	Nylon Plastic	Polyester Plastic
Ultraviolet <sup>A</sup>	x	x	x	...	x	...	...	...
Moisture	x	x	x	...	x	x	...	x
Elevated temperatures	x	x	x	x	x	...	x	x
Low temperatures	x	x	x	x	x	...	x	x
Exposure to corrosives	...	...	...	x	x	x	x	x
Concern for damage to unit surface	...	...	...	x	x	x	x	x

<sup>A</sup> UV inhibitors are available for polypropylene, nylon, and polyester plastics.

in sudden strap failure or breakage of tensioner with potential severe injury to the operator.

5.6 *Improper Use*— Strapping should be used only as intended.

5.6.1 *Punching or Nailing*—Never punch strapping with nails, staples, or other sharp objects. This may cause premature strap failure. Also, attempting to nail through steel strapping may present a hazard especially when power nailing or stapling. Type 2 steel strapping has pre-punched holes intended for nail-on applications.

5.6.2 *Pulling or Dragging*—Never use strapping as a means of pulling or dragging any packages or unit.

5.6.3 *Lifting*—Never use strapping as a means of lifting unless applied using the Unit Strap Lifting Method (USLM) system.

5.7 *Unit Strap Lifting Method (USLM) Hazards*—USLM is a specialized application of USLM steel strapping for overhead lifting and transport of large, heavy packages. Before considering a USLM application consult a USLM system vendor and transportation or port regulatory authorities for rules and considerations in application. Note the following warnings:

5.7.1 *Compliance and Training*—Compliance with all safety aspects of USLM application is critical to protect personnel. Always train all users before using the USLM or handling USLM loads.

5.7.2 *Specified Strapping and Seals*—Always use correctly marked USLM steel strapping and seals (see Specification D 3953). Strapping and seals must be applied so that markings are visible.

5.7.3 *Lifting Capacity*—Consult transport or port regulations and your USLM system supplier to determine the lifting capacity of strapping. Do not exceed the calculated lifting capacity.

5.7.4 *Damaged or Used Straps or Seals*—Never use damaged or used USLM strap or seals.

5.7.5 *Stand Clear*—Before lifting, be sure all personnel are away from the unit load. Never stand underneath or near a load being lifted.

5.7.6 *System Audit*—USLM systems require periodic performance audit. Consult your USLM system vendor.

## GENERAL CONSIDERATIONS

### 6. General Properties of Strap Types (See Table 2 and, Table 3, and Table 4)

6.1 *Steel Strapping*— This product is described in Specification D 3953 and is generally classified into regular-duty, regular-duty high strength and heavy-duty strapping. Of all the types of strapping, steel strapping has the highest tensile strength (break strength for a given cross-sectional area) and resistance to tension decay or creep. It is better suited to expanding or rigid units than it is to units that settle because it has a low settling tolerance. Regular-duty high strength strap is suggested for applications where high strength alone is the overriding consideration. Heavy-duty and USLM steel strapping are suggested for applications where both break strength and elongation are overriding considerations. Heavy-duty steel strapping is also suggested for high-temperature applications.

6.2 *Nonmetallic Strapping:*

6.2.1 *Corded Strapping (Type I and IA)*—These products are described in Specification D 3950. Corded strapping consists of two basic types, rayon (Type I) and polyester (Type IA).

6.2.1.1 Of all types of strapping, polyester corded has high energy to break for a given cross section. Heavy-duty and extra-heavy-duty polyester corded strappings are suggested for applications where break strength and energy to break are overriding considerations. Polyester corded strapping is more resistant to weathering and moisture than rayon corded strapping. Use wire buckles where maximum joint efficiency is required. Corded strapping may also be joined using plastic buckles, seals, or hand-tied knots.

6.2.2 *Polypropylene (Type II)*—Polypropylene strapping is described in Specification D 3950. Polypropylene strapping is used to describe strapping made from two closely related materials, polypropylene homopolymer and polypropylene copolymer. While these materials have excellent resistance to moisture they are the least heat-resistant of all the common strapping materials and also have the greatest tension decay or creep of any of the common materials. Of the nonmetallic strapping materials, they are the most easily heat sealed or fusion joined. They tend to be more suitable for light to medium duty applications.

6.2.3 *Nylon (Type III)*—Nylon strapping is described in Specification D 3950. Nylon strapping has the highest elongation recovery of any strapping material, that, combined with a relatively low dead stretch, gives it the highest settling tolerance. With loads where severe settling is the major consideration, nylon would be the preferred strapping material. In terms of break strength, it is comparable to that of the polypropylene and polyester strapping material. It has the best cold-temperature performance of the nonmetallic group, but is most susceptible to moisture degradation.

6.2.4 *Polyester (Type IV)*—Polyester strapping is described in Specification D 3950. Polyester has the lowest elongation in the working range and the least tension decay or “creep” of all the nonmetallic strappings. This makes it somewhat more suitable for rigid and expanding loads. Polyester strapping generally exhibits good resistance to the effects of temperature and moisture.

### 7. General Uses

7.1 Strap may be used to secure a handling base (skids, platforms, pallets, runners, spacers, etc.) to a unit to expedite handling, for example, 2 by 4-in. (5.08 by 10.16 mm) runners strapped to a concrete or steel slab to allow a fork lift or crane and cable handling or to secure other packaging materials (battens, stiffeners, wrappings, etc.), or both, in position. (See Fig. 1.)

7.2 Strap may be used for load securement to or within the transport vehicle. It is then applied under tension to restrain or control the movement of lading, and thus must accommodate in-transit shocks or irregular movements. Carrier regulations provide guidelines or minimum requirements, or both.

**TABLE 2 Strapping Applications Commonly Used for Packaging, Unitization, and Load Securement**

Industry	Product	ASTM D3953-Standard Specification for Strapping Flat Steel and Seals			ASTM D3950-Standard Specification for Strapping Nonmetallic (and Joining Methods)				
		Hand or Machine Applied			Hand Applied	Hand or Machine Applied			
		Type I Steel Regular Duty	Type I Steel Regular Duty High Strength	Type I Steel Heavy Duty	Type IA Bonded, Woven or Composite Polyester Cord	Type I Bonded Rayon Cord	Type II Polypropylene (Plastic)	Type III Nylon (Plastic)	Type IV Polyester (Plastic)
	Moderate Tensile Strength Low Elongation High Retained Tension	High Tensile Strength Low Elongation High Retained Tension	High Tensile Strength Moderate Elongation High Retained Tension	Good Tensile Strength Moderate Elongation Good Retained Tension High Energy-to-Break Good Notch Sensitivity	Moderate Tensile Strength Moderate Elongation Good Notch Sensitivity	Low Tensile Strength High Elongation Low Retained Tension Good Tension Recovery	Moderate Tensile Strength Good Elongation Good Retained Tension Good Tension Recovery	Good Tensile Strength Moderate Elongation Good Retained Tension High Energy-to-Break	
General	Appliances	3/8" & 1/2"					7/16"	7/16"	5/8"
	Carton Closure					3/16", 1/4" & 3/8"	1/4" & 3/8"	3/8"	
	Flat Glass		5/8" & 3/4"		5/8" & 3/4"				5/8" & 3/4"
	PVC Pipe	3/4"	5/8" & 3/4"		1/2" to 3/4"		7/16"	7/16"	1/2", 5/8" & 3/4"
Agriculture	Food Products in Wood Bins			3/4"	5/8" & 3/4"				5/8"
	Hay Baling						1/2"		1/2"
	Cotton			3/4"					3/4"
	Tobacco			1/2", 5/8" & 3/4"			1/2"		
Beverage	Fibers (Manmade & Natural)	5/8" & 3/4"	5/8" & 3/4"	1/2", 5/8" & 3/4"					5/8" & 3/4"
	PET Bottles							3/8"	3/8"
	Cans							3/8"	3/8"
Corrugated	Glass Bottles						7/16" & 1/2"		7/16" & 1/2"
	KD Boxes	3/8"					7/16"		7/16"
Graphic Arts	Corrugated Sheet Load	3/8", 5/8" & 3/4"					7/16"		7/16"
	Signature Logs						7/16" & 1/2"		7/16" & 1/2"
	Magazines						5mm, 3/16" & 1/4"		
	Newspapers						5mm, 3/16" & 1/4"		
Masonry	Palletized Printed Loads		1/2" & 5/8"		1/2" & 5/8"				7/16", 1/2" & 5/8"
	Brick		1/2"	1/2"					5/8"
	Block/Pavers		1/2" & 5/8"	1/2" & 5/8"					5/8" & 3/4"
Forest Products	Roof Tiles						7/16"		
	Lumber	5/8" & 3/4"	1/2", 5/8" & 3/4"	5/8" & 3/4"	5/8", 3/4", 1" & 1-1/4"				5/8" & 3/4"
	Hardwoods	3/4"		3/4"	5/8" & 3/4"				3/4" & 1"
	Hardboard Siding	5/8" & 3/4"		5/8" & 3/4"	5/8" & 3/4"				5/8"
	Pressure Treated Lumber	5/8" & 3/4"	5/8" & 3/4"	5/8" & 3/4"	5/8" & 3/4"				5/8"
Panel Products	Landscape Timbers	3/4"		3/4"	5/8", 3/4" & 1"				5/8"
	Flakeboard, MDF, OSB, Particleboard & Plywood		5/8"	5/8"	5/8" & 3/4"				5/8" & 3/4"
Engineered Wood Products	I-Joists, LVL, PSL & LSL			3/4" & 1-1/4"	5/8", 3/4", 1" & 1-1/4"				5/8" & 3/4"
	Paper	3/8" & 1/2"							7/16"
Metals	Paper Rolls					3/16", 1/4" & 3/8"	1/4" & 3/8"	3/8"	
	Copy Paper in Cartons								
	Aluminum Ingots			3/4" & 1-1/4"					5/8", 3/4", 1" & 1-1/4"
	Aluminum Billets			3/4"					3/4", 1" & 1-1/4"
	Aluminum Extrusions			5/8" & 3/4"	1/2", 5/8" & 3/4"				5/8"
	Scrap Aluminum			5/8" & 3/4"					5/8" & 3/4"
	Aluminum Rod			3/4" & 1-1/4"	5/8", 3/4" & 1"				3/4" & 1"
	Coiled Copper Rod			1-1/4"	3/4", 1" & 1-1/4"				3/4" & 1"
	Steel Wire			1-1/4"	3/4", 1" & 1-1/4"				5/8" & 3/4"
	Steel Structural Shapes			3/4" & 1-1/4"	5/8", 3/4", 1" & 1-1/4"				3/4" & 1"
	Cut-to-Length Flat Sheet Stock			5/8", 3/4" & 1-1/4"	5/8", 3/4", 1" & 1-1/4"				5/8", 3/4", 1" & 1-1/4"
Steel Tubing			5/8", 3/4" & 1-1/4"	5/8", 3/4", 1" & 1-1/4"				3/4" & 1"	
Steel Coils	1/2", 5/8" & 3/4"		5/8", 3/4" & 1-1/4"	3/4", 1" & 1-1/4"				5/8", 3/4" & 1"	
Load Securement	Truck & Railcar Unitization			3/4" & 1-1/4"	3/4", 1" & 1-1/4"				
	Truck Tie Down			1-1/4"					
	Railcar Doorway Protection			3/4" & 1-1/4"	1-1/4" & 1-1/2"				
	Open Top Railcar Tie Down			3/4", 1-1/4" & 2"					
Unit Strap Lifting Method				1-1/4" USLM					

**TABLE-2 3 Strapping Preference as a Function of Unit Type**

Strapping Type	Unit Type				
	Severely <sup>A</sup> Settling	Moderately <sup>B</sup> Settling	Rigid	Moderately Expanding	Severely Expanding
<i>Specification D 3953:</i> Steel Strapping Regular Duty, Regular-Duty High Strength or Heavy Duty	...	...	C	C	D
<i>Specification D 3950:</i> Type I Cord Strapping (Rayon) (Regular Duty)	E	C	C	C	...
Type IA Cord Strapping (Polyester)	E	C	C	C	C
Polypropylene Plastic Strapping	E	C	C	...	...
Nylon Plastic Strapping	E	C	C	...	...
Polyester Plastic Strapping	E	C	C	C	C

<sup>A</sup> Severe—A perimeter change of 2 % or more.  
<sup>B</sup> Moderate—A perimeter change of less than 2 %.  
<sup>C</sup> Generally recommended.  
<sup>D</sup> Best choice, other factor being equal.  
<sup>E</sup> With buckles, can be retensioned.

**TABLE-3 4 Minimum Sizes of Steel and Plastic Strapping for Fiberboard Boxes**

Gross Weight of Container and Contents, lb	Specification D 3953, Type 1, in.	Nonmetallic <sup>A</sup> Specification D 3950	
		Type II, in.	Type III, in.
0 to 35	5/8 by 0.010	3/8 by 0.015 1/4 by 0.025	7/16 by 0.017 1/2 by 0.015
35 to 70, incl	3/8 by 0.015	3/8 by 0.015 1/4 by 0.025 7/16 by 0.025	7/16 by 0.017 1/2 by 0.015
70 to 110, incl	3/8 by 0.020 1/2 by 0.015	1/2 by 0.015 3/8 by 0.020 7/16 by 0.025	1/2 by 0.015 7/16 by 0.017
Over 110 to 225, incl	1/2 by 0.020 5/8 <sup>A</sup> by 0.015	1/2 by 0.020 3/8 by 0.015 7/16 by 0.025	7/16 by 0.023 1/2 by 0.020

<sup>A</sup> Other type and sizes may be applicable.

7.3 Strapping may be used for lifting only if applied using the Unit Strap Lifting Method (USLM). Consult transportation or port regulatory authorities and a USLM system supplier for application requirements. USLM is a system for lifting unitized loads with specialized lifting gear and USLM steel strapping and seals, applied with specialized tensioners and sealers. USLM is used on a variety of bulk cargos, for example, wood pulp, logs, and metal billets.

7.4 Strap also may provide security against accidental loss or theft of the contents or indicate a loss or theft.

7.5 Strap functions best when all resultant forces act directly parallel, in line, with the direction of the strap.

## 8. Strap Tension

8.1 Strap primarily functions under tension. This tension basically:

8.1.1 Imposes circumferential (peripheral) compressive forces to resist a change in configuration, for example, tubing secured in hexagonal or round unit, scrap paper secured in bales, etc., or the following, or both. (See Fig. 1.)

8.1.2 Increases the frictional forces between the adjacent surfaces within the unit, for example, between cartons on a pallet and between the cartons and the pallet.

## PACKAGING DESIGN

### 9. Distribution

9.1 Identify receivers (consignees) and their locations relative to shipping point(s) (consignors).

9.2 Determine receiver's needs and requirements. This will provide information on handling equipment and practices, storage practices and conditions, and possible specific requirements of individual users.

9.3 Determine applicable transportation modes: air, water, rail, or truck. This will further define the shipping conditions and applicable rules and regulations. See 2.2.

9.4 Contact potential carriers within each mode and determine if there are any general or specific rules and regulations.

9.5 The carriers can provide information as to the type of equipment that will best suit specific needs.

## 10. Package Configuration

10.1 Generally, the “ideal” package configuration is one that:

- 10.1.1 Can be safely handled in the distribution system,
- 10.1.2 Protects the security of the contents,
- 10.1.3 Meets the receiver’s requirements,
- 10.1.4 Secures easily on or to transportation equipment,
- 10.1.5 Maximizes use of space in warehouses and transportation equipment, and
- 10.1.6 Can be easily assembled and disassembled.

10.2 The configuration used should have its center of gravity as low as practical for maximum stability during handling, transit, and storage.

## 11. Strap Selection

11.1 Strap size, type, placement, and number required are all a function of the work to be done, that is determined by a number of factors. These factors include: number and direction of shear planes, friction of contact surfaces between all shear planes, size, shape and weight of unit load, expected severity of handling, nature of transport equipment, and exposure to environmental conditions, particularly if prolonged outdoor exposure is anticipated. (See Table 1.)

11.2 Contents have a tendency to react in one of three ways. They can expand, remain rigid, or settle. Contents may appear to be one type and later with different conditions exhibit the characteristic of another type. Strap selection must accommodate anticipated content reaction.

11.2.1 *Expanding Contents:*

- 11.2.1.1 Natural and synthetic fibers, or scrap paper that are compressed prior to strap placement,
- 11.2.1.2 Lumber that is dry when strapped will tend to expand if it gets wet, or
- 11.2.1.3 Any “springy” material such as rolls of concrete reinforcing mesh, compressed coils of metal rod, or corrugated fiberboard sheets in bundles.

11.2.2 *Settling Contents:*

- 11.2.2.1 Powders in cartons, bags, or other soft containers,
- 11.2.2.2 Jars or cans packed with corrugated or fiberboard interleaves, or,
- 11.2.2.3 Lumber that is wet or green when strapped.

11.2.3 *Rigid Contents:*

- 11.2.3.1 Concrete or metal slabs,
- 11.2.3.2 Exterior grade plywood, or
- 11.2.3.3 Primary metal products.

11.3 *Shear Planes*—The number of shear planes within a load affects strap selection and placement. Generally the more shear planes within a load, the more restraint required to maintain package integrity. Supplementary materials such as edge protectors and battens may be used to augment the strap effectiveness. (See Fig. 1.)

11.3.1 *Examples of Flat Surface Shear Planes:*

- 11.3.1.1 Multiple horizontal only; plywood sheathing,
- 11.3.1.2 Multiple horizontal and unidirectional vertical; dimensioned lumber, and
- 11.3.1.3 Multiple horizontal and bidirectional vertical; brick.

11.3.2 *Curved Surface Shear Planes*—Cylindrical objects that are not stacked vertically have a complex (curved) shear plane that tends to restrict sliding to horizontally in the lengthwise direction only. If cylindrical objects are stacked vertically, the shear planes are multiple in all directions.

11.4 *Coefficient of Friction*—The coefficient of friction of the contact surfaces is also a major consideration. A package of rough cut 2-by-4’s does not require as much restraint as an identical load of surfaced (finished) 2-by-4-in. (5.08 by 10.16-mm) lumber. A similar example would be dry metal sheets versus heavily oiled sheets. A function of a strap is to increase friction between internal surfaces. If the coefficient of friction is high, less force applied by the strap is required for equivalent integrity. Friction will also help offset the loss of integrity caused by multiple shear planes.

## JOINING METHODS AND PROPERTIES

### 12. Joint Methods and Properties (Except Loop Joints)

12.1 *Joints*—Joints are generally the weakest link in the completed strap system. It is therefore very important that all elements contributing to form a joint are compatible. These elements follow:

12.1.1 *Strap*—Size, type, and coating or finish,

12.1.2 *Seal*—Must be compatible with strap and sealing mechanism. Seals for steel and nonmetallic strap, although similar, are not interchangeable.

12.1.3 *Sealing Mechanism*—Must be compatible with strap and seal and must be in good mechanical condition. Sealing mechanisms for steel and nonmetallic strap, although similar, are not interchangeable.



12.1.4 *Operator Technique*—Combine above elements together properly, as designed.

12.1.5 *Periodic Testing of Joints* —To ensure that all parts of the system are functioning properly, sample joints must periodically be tested. Test joints should be taken from applied production straps. A joint may have all the appearances of a good joint, but have less than required strength.

12.2 *Lap Joint*—The jointing of two ends of strapping around a unit for securement with one of the listed procedures that follow: other than loop joint. (For loop joint see 13.3.)

12.3 *Notch Joint and Seals (Steel)* :

12.3.1 A notch joint is a mechanical interlocking of the overlapping strap ends that are within a seal. The interlocking consists of tabs that are formed in pairs on either side by shearing and bending partially through the seal and strap edges.

12.3.2 Sealing mechanisms may be designed to form either up-cut or down-cut tabs. Up-cut tabs are to minimize gouging surface contents and containers. (See Fig. 2.)

12.3.3 Effectiveness of notch joints is a function of:

- 12.3.3.1 Yield/tensile ratio of strap,
- 12.3.3.2 Depth and number of pairs of notches,
- 12.3.3.3 Mechanical properties of seal, and
- 12.3.3.4 Design and condition of sealing mechanism, and operator technique.

12.3.4 The joint will always be something less than 100 % of actual strap break strength because the effective strap cross section is reduced in the shearing action to form the tabs. A single pair of notches is required to produce a minimum joint efficiency of

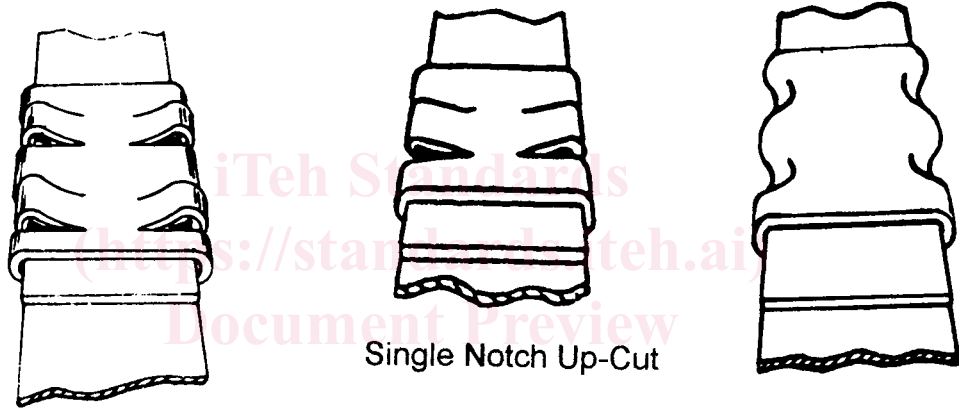

Double Notch Up-Cut

Single Notch Up-Cut

Double-Friction Crimp

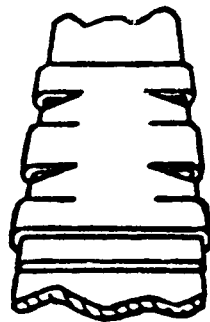

Double Notch Down-Cut



Three Key Sealless Locking Joint



Four Key, Reverse Sealless Locking Joint

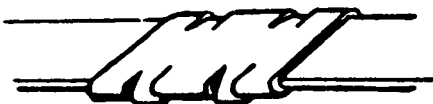

FIG. 2 Joints for Metal Strapping

45 % and two pairs of 75 %. Straps having a cross section greater than 1¼ by 0.035 in. (31.75 by 0.89 mm) may require additional seals or pairs of notches to obtain maximum joint efficiency, and the seals must be heavier gage; approaching the thickness of parent strapping.

12.3.5 When properly made notch joints fail, they usually fail by the strap breaking at the notch, causing sudden and total release of the strap tension. However, if notches are poorly formed, seal is too weak, or the sealing mechanism is badly worn, the joint may fail by the strap pulling out at a lower load value.

12.4 *Crimp, Friction, Joint, and Seals*—Friction is developed in a crimp joint (see Figs. 2 and 3) by pairs of deformations in the edges or top of the seals, and the overlapped strap ends. Since the strap is not cut, the maximum potential joint strength can approach the parent strap strength. The finish on the strap will affect its lubricity and consequently the number of crimp pairs required.

12.4.1 Some styles of crimp seals are available with a “grit” (abrasive material), knarled or scored, internal surface that augments the friction to provide higher joint strengths on lubricated metal strapping. The same is true on polypropylene, polyester, and nylon nonmetallic strapping.

12.4.2 Crimp joints tend to fail by slipping, but may allow some retention value to be maintained. This is the “slip and hold” characteristic.

12.5 *Welded Joint (Nonmetallic Strap)* —All types except corded strap can be heat-sealed or friction-welded. Joint strengths vary with the type of strapping and means of application.

12.6 *Buckle Joints for Nonmetallic Strapping*—Wire buckles are suggested for corded strapping to obtain maximum joint strength. Nonmetallic and wire buckles may also be used for other types of nonmetallic strapping. (See Fig. 4.)

12.7 *Interlocking Joint (Steel Strap Only)*—Sometimes referred to as “seal-less” joint. Overlapping ends are aligned and simultaneously die cut to form a mechanical interlock. Potential joint strength is less than that of the parent strap.

12.8 *Seals End-Use Applications Determine Style*—The use of a particular style depends on the application and the sealing mechanism used. The length of the seals vary depending on whether they will be notched or crimped one or more times, and according to the manufacturer’s standards. Material thickness and hardness contribute to performance. The seal must be able to be notched, if notch type, or crimped, if crimp type, without tearing or cracking.

12.8.1 *Style I—Snap-On (Open or Semi-Open)*—Style I can be applied either during or after tensioning. This style is used primarily with feed-wheel (rotary dog) type tensioning tools, on flat strapping surfaces, where strap is fed direct from coil. (See Fig. 5 and Fig. 6.)

12.8.2 *Style II—Thread On or Closed*—Style II is normally used to help maintain strap alignment during tensioning. This style is normally used on flat surfaces with windless type (slotted drum) tensioning tools. Strap must be pre-threaded through the seal before draping around load, and threading in tensioning tool. (See Fig. 7 and Fig. 8.)

12.8.3 *Style III—Push Type*—Style III is used for applications involving round- or irregular-shaped units or bundles such as coils, pipe, coiled rod, and small surfaces using pusher-type tensioning tool. Strap is generally used direct from the coil, threaded through the seal, and formed into a “lasso” or slip loop that is then cinched around the unit, hand tight. Pusher bar nose of tool pushes against rear end of seal as tension is applied, thus the name “push type”. (See Fig. 9 and Fig. 10.)

12.8.4 *Style IV—Magazine Feed* —Style IV seals are loaded into the magazine and mechanically fed to the sealing position

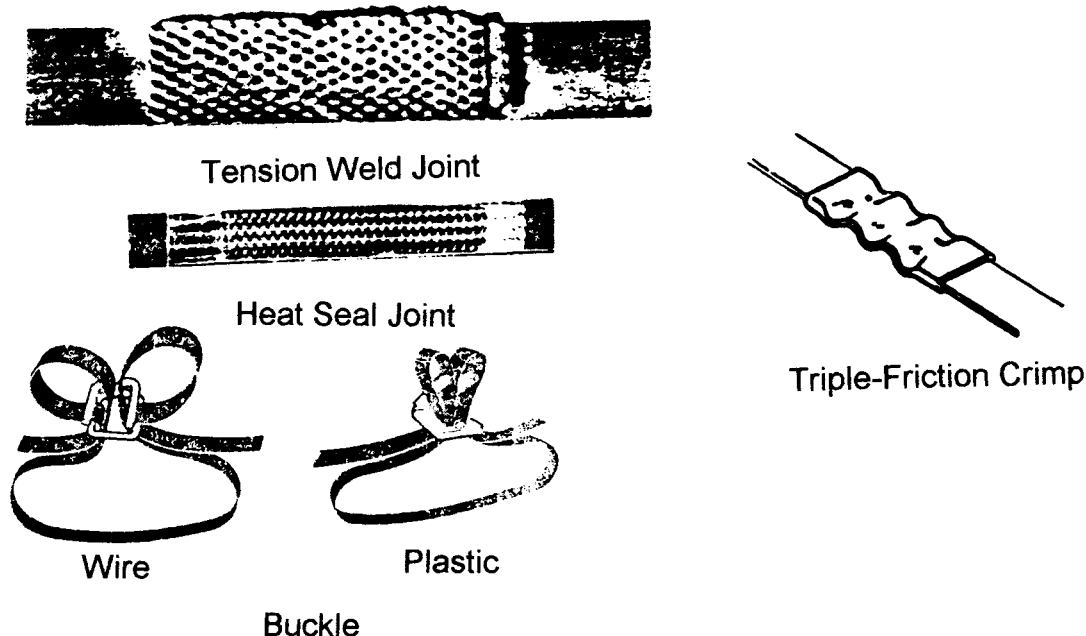

FIG. 3 Joints for Nonmetallic Strapping