**Mechanical pencils and leads
for general use — Classification,
dimensions, quality and test
methods —**

Part 1:

Mechanical pencils

iTeh STANDARD PREVIEW

(standards.iteh.ai)
*Porte-mines et mines pour usage général — Classification,
dimensions, qualité et méthodes d'essai —*

Partie 1: Porte-mines

<https://standards.iteh.ai/catalog/standards/sist/9c148144-9372-422f-be28-4b6c257cec50/iso-20318-1-2019>



iTeh STANDARD PREVIEW
(standards.iteh.ai)

ISO 20318-1:2019

<https://standards.iteh.ai/catalog/standards/sist/9c148144-9372-422f-be28-4b6c257cec50/iso-20318-1-2019>



COPYRIGHT PROTECTED DOCUMENT

© ISO 2019

All rights reserved. Unless otherwise specified, or required in the context of its implementation, no part of this publication may be reproduced or utilized otherwise in any form or by any means, electronic or mechanical, including photocopying, or posting on the internet or an intranet, without prior written permission. Permission can be requested from either ISO at the address below or ISO's member body in the country of the requester.

ISO copyright office
CP 401 • Ch. de Blandonnet 8
CH-1214 Vernier, Geneva
Phone: +41 22 749 01 11
Fax: +41 22 749 09 47
Email: copyright@iso.org
Website: www.iso.org

Published in Switzerland

Contents

	Page
Foreword	iv
Introduction	v
1 Scope	1
2 Normative references	1
3 Terms and definitions	1
4 Classification	2
4.1 General.....	2
4.2 Type according to mechanism.....	2
4.3 Type according to marking diameter.....	2
5 Dimensions	4
5.1 Bore size.....	4
6 Quality	5
6.1 Performance.....	5
7 Test methods	5
7.1 Test conditions.....	6
7.2 Bore size dimension.....	6
7.3 Operability.....	6
7.4 Lead holdability (clamping force).....	6
7.5 Residual length of lead.....	6
7.6 Tip load.....	7
7.7 Shock resistance.....	8
7.8 Durability.....	8
8 Designation	8
Bibliography	9

Foreword

ISO (the International Organization for Standardization) is a worldwide federation of national standards bodies (ISO member bodies). The work of preparing International Standards is normally carried out through ISO technical committees. Each member body interested in a subject for which a technical committee has been established has the right to be represented on that committee. International organizations, governmental and non-governmental, in liaison with ISO, also take part in the work. ISO collaborates closely with the International Electrotechnical Commission (IEC) on all matters of electrotechnical standardization.

The procedures used to develop this document and those intended for its further maintenance are described in the ISO/IEC Directives, Part 1. In particular, the different approval criteria needed for the different types of ISO documents should be noted. This document was drafted in accordance with the editorial rules of the ISO/IEC Directives, Part 2 (see www.iso.org/directives).

Attention is drawn to the possibility that some of the elements of this document may be the subject of patent rights. ISO shall not be held responsible for identifying any or all such patent rights. Details of any patent rights identified during the development of the document will be in the Introduction and/or on the ISO list of patent declarations received (see www.iso.org/patents).

Any trade name used in this document is information given for the convenience of users and does not constitute an endorsement.

For an explanation of the voluntary nature of standards, the meaning of ISO specific terms and expressions related to conformity assessment, as well as information about ISO's adherence to the World Trade Organization (WTO) principles in the Technical Barriers to Trade (TBT) see www.iso.org/iso/foreword.html.

This document was prepared by Technical Committee ISO/TC 10, *Technical product documentation*.

A list of all parts in the ISO 20318 series can be found on the ISO website.

Any feedback or questions on this document should be directed to the user's national standards body. A complete listing of these bodies can be found at www.iso.org/members.html.

Introduction

This document was developed in response to the recent increase in popularity of mechanical pencils and their leads among students who use them for general writing, and where varieties of both hardness degrees and thickness (designated as marking diameter) of leads have been expanding in response to different types of usage. It should be noted that the entire production volume of mechanical pencils has been increasing every year, whereas the production of mechanical pencils for technical drawings has been decreasing.

Despite these recent trends, ISO 9177-1 was revised in 2011 with a scope limited to technical drawing usage only.

Therefore, it is clear that this document is necessary for general use and that it should be independent of technical drawings. The ISO 20318 series consists of two parts: mechanical pencils and black leads.

A set of a mechanical pencil and lead of the same marking diameter should be completely complementary, and should be compatible even with pencils and lead from different manufacturers.

It should also be noted that there are two issues which have not been resolved since the first relevant standard was published. First, on marking of labelling the diameters on mechanical pencils and cases of leads, two designations coexist: 0,35 and 0,3 and 1 and 0,9. This document attempts to clarify this designation issue by defining diameters precisely. Second, a scientific definition of hardness degree of leads is not yet available. Even though this document tried to establish a solely quantitative evaluation method, qualitative evaluation turned out to be inevitable. The issue, therefore, remains unresolved.

The title of the 2016 third edition of ISO 9177-1 was revised to distinguish it clearly from this document with the addition of “for technical drawings”.

iTeh STANDARD PREVIEW
(standards.iteh.ai)
ISO 20318-1:2019
<https://standards.iteh.ai/catalog/standards/sist/9c148144-9372-422f-bc28-4b6c257cec50/iso-20318-1-2019>

iTeh STANDARD PREVIEW
(standards.iteh.ai)

ISO 20318-1:2019

<https://standards.iteh.ai/catalog/standards/sist/9c148144-9372-422f-be28-4b6c257cec50/iso-20318-1-2019>

Mechanical pencils and leads for general use — Classification, dimensions, quality and test methods —

Part 1: Mechanical pencils

1 Scope

This document specifies classification, dimensions, quality and test methods for hand-held mechanical pencils which hold and feed out a lead, and are used for general writing. It is also applicable to multi-function pens equipped with a mechanical pencil unit. However, those pencils attached to machinery instruments such as a plotter are excluded.

2 Normative references

The following documents are referred to in the text in such a way that some or all of their content constitutes requirements of this document. For dated references, only the edition cited applies. For undated references, the latest edition of the referenced document (including any amendments) applies.

ISO 20318-2, *Mechanical pencils for general use — Classification, dimensions, quality and test methods — Part 2: Black leads*

3 Terms and definitions

For the purposes of this document, the terms and definitions given in ISO 20318-2 and the following apply.

ISO and IEC maintain terminological databases for use in standardization at the following addresses:

- ISO Online browsing platform: available at <https://www.iso.org/obp>
- IEC Electropedia: available at <http://www.electropedia.org/>

3.1

mechanical pencil

writing instrument which holds and feeds out a lead

3.2

multi-function pen

writing instrument which can be equipped with two or more writing units (mechanical pencil unit and refills of gel ink ball pen or ball-point pen)

Note 1 to entry: At least one of these units is a mechanical pencil unit.

3.3

marking diameter

numerical symbol used for classification of mechanical pencils

Note 1 to entry: This corresponds to the classification of leads for mechanical pencils specified in ISO 20318-2.

3.4

nose cone

front part of a mechanical pencil

Note 1 to entry: Varieties include a nose cone without a guide pipe, a nose cone with a fixed guide pipe and a nose cone with a moving guide pipe.

Note 2 to entry: See Figures 1 and 2.

3.5

bore size

inside diameter of the guide pipe or a nose cone without a guide pipe, through which a lead emerges

3.6

residual length of lead

length of a lead remaining in a nose cone when approaching a state where writing is impossible as a result of dislocation of the lead from the chuck by pushing

4 Classification

4.1 General

Mechanical pencils shall be classified according to the type of mechanism (see [Table 1](#) and [Figures 1](#) and [2](#)) and the marking diameter (see [Table 2](#)). The classification, quality, dimensions and test methods of the lead for mechanical pencils shall be in accordance with ISO 20318-2.

4.2 Type according to mechanism

The type according to mechanism shall be in accordance with [Table 1](#).

<https://standards.iteh.ai/catalog/standards/sist/9c148144-9372-422f-be28-577777777777/iso-20318-1-2019>

Table 1 — Type according to mechanism

Mechanism	Type	Description	Relevant figure
Push-type	F	Mechanical pencil in which the lead, housed in a barrel, is fed out by a specified length by actuating a push mechanism	Figure 1
Mechanical pencil unit	M	Same as type F but equipped in a multi-function pen	Figure 2

4.3 Type according to marking diameter

The type according to marking diameter shall be in accordance with [Table 2](#).

Table 2 — Type according to marking diameter

Dimensions in millimetres

Marking diameter for mechanical pencil	Diameter of ISO 20318-2		Informative	
	Marking diameter	Range of actual diameter	Nominal diameter according to ISO 9177-1 and ISO 9177-2	Line width according to ISO 128-20
0,2	0,2	0,27 to 0,29	—	0,25
0,3	0,3	0,37 to 0,39	0,35	0,35
0,4	0,4	0,46 to 0,48	—	—
0,5	0,5	0,55 to 0,58	0,5	0,5
0,7	0,7	0,69 to 0,73	0,7	0,7

Table 2 (continued)

Marking diameter for mechanical pencil	Diameter of ISO 20318-2		Informative	
	Marking diameter	Range of actual diameter	Nominal diameter according to ISO 9177-1 and ISO 9177-2	Line width according to ISO 128-20
0,9	0,9	0,88 to 0,92	1	1
1,3	1,3	1,25 to 1,32	—	—
1,4	1,4	1,37 to 1,44	—	1,4
2	2	1,95 to 2,05	2	2

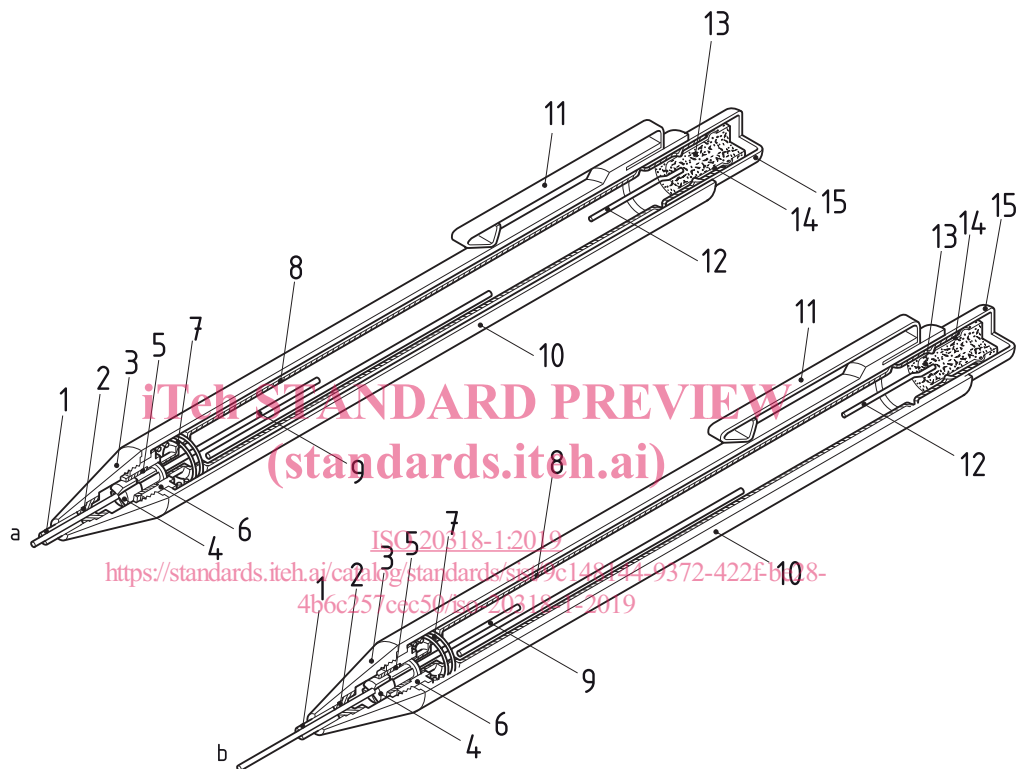

Key

- | | | | |
|---|---------------|----|---------------------------|
| 1 | guide pipe | 10 | barrel |
| 2 | lead retainer | 11 | clip |
| 3 | nose cone | 12 | cleaning pin |
| 4 | chuck | 13 | eraser |
| 5 | chuck ring | 14 | eraser ferrule |
| 6 | nipple | 15 | push button |
| 7 | spring | a | Lead in working position. |
| 8 | lead tube | b | Lead in feeding position. |
| 9 | lead | | |

Figure 1 — Mechanical pencil of push-type F