**Iron ores — Determination of sulfur
content —**

**Part 3:
Combustion/infrared method**

Minerais de fer — Dosage du soufre —

Partie 3: Méthode par combustion et infrarouge

**iTeh STANDARD PREVIEW
(standards.iteh.ai)**

ISO 4689-3:2015

<https://standards.iteh.ai/catalog/standards/sist/4B808d5-c969-4514-8135-16e0f72e91B/iso-4689-3-2015>



iTeh STANDARD PREVIEW
(standards.iteh.ai)

[ISO 4689-3:2015](https://standards.iteh.ai/catalog/standards/sist/4f3808d5-c969-4514-8135-16e0f72e91f3/iso-4689-3-2015)

<https://standards.iteh.ai/catalog/standards/sist/4f3808d5-c969-4514-8135-16e0f72e91f3/iso-4689-3-2015>



COPYRIGHT PROTECTED DOCUMENT

© ISO 2015, Published in Switzerland

All rights reserved. Unless otherwise specified, no part of this publication may be reproduced or utilized otherwise in any form or by any means, electronic or mechanical, including photocopying, or posting on the internet or an intranet, without prior written permission. Permission can be requested from either ISO at the address below or ISO's member body in the country of the requester.

ISO copyright office
Ch. de Blandonnet 8 • CP 401
CH-1214 Vernier, Geneva, Switzerland
Tel. +41 22 749 01 11
Fax +41 22 749 09 47
copyright@iso.org
www.iso.org

Contents

	Page
Foreword.....	iv
Introduction.....	v
1 Scope.....	1
2 Normative references.....	1
3 Principle.....	1
4 Reagents.....	1
5 Apparatus.....	2
6 Sampling and samples.....	5
6.1 Laboratory sample.....	5
6.2 Preparation of predried test samples.....	5
7 Procedure.....	5
7.1 Number of determinations.....	5
7.2 Test portion.....	5
7.3 Blank test and check test.....	5
7.4 Determination.....	6
7.5 Preparation of calibration graph.....	6
8 Expression of results.....	7
8.1 Calculation of sulfur content.....	7
8.2 General treatment of results.....	7
8.2.1 Repeatability and permissible tolerance.....	7
8.2.2 Determination of analytical result.....	7
8.2.3 Between-laboratories precision.....	8
8.2.4 Check for trueness.....	8
8.2.5 Calculation of final result.....	9
9 Test report.....	9
Annex A (normative) Flowsheet of the procedure for the acceptance of analytical values for test samples.....	10
Annex B (informative) Derivation of repeatability and permissible tolerance equations.....	11
Annex C (informative) Precision data obtained by international analytical trial.....	12
Bibliography.....	13

Foreword

ISO (the International Organization for Standardization) is a worldwide federation of national standards bodies (ISO member bodies). The work of preparing International Standards is normally carried out through ISO technical committees. Each member body interested in a subject for which a technical committee has been established has the right to be represented on that committee. International organizations, governmental and non-governmental, in liaison with ISO, also take part in the work. ISO collaborates closely with the International Electrotechnical Commission (IEC) on all matters of electrotechnical standardization.

The procedures used to develop this document and those intended for its further maintenance are described in the ISO/IEC Directives, Part 1. In particular the different approval criteria needed for the different types of ISO documents should be noted. This document was drafted in accordance with the editorial rules of the ISO/IEC Directives, Part 2 (see www.iso.org/directives).

Attention is drawn to the possibility that some of the elements of this document may be the subject of patent rights. ISO shall not be held responsible for identifying any or all such patent rights. Details of any patent rights identified during the development of the document will be in the Introduction and/or on the ISO list of patent declarations received (see www.iso.org/patents).

Any trade name used in this document is information given for the convenience of users and does not constitute an endorsement.

For an explanation on the meaning of ISO specific terms and expressions related to conformity assessment, as well as information about ISO's adherence to the WTO principles in the Technical Barriers to Trade (TBT) see the following URL: [Foreword - Supplementary information](#).

The committee responsible for this document is ISO/TC 102, *Iron ore and direct reduced iron, Subcommittee*, Subcommittee SC 2, *Chemical analysis*.

This second edition cancels and replaces the first edition (ISO 4689-3:2004), of which 4.6 and 8.2.4 have been technically revised.

ISO 4689 consists of the following parts, under the general title *Iron ores — Determination of sulfur content*:

- *Part 1: Barium sulfate gravimetric method*
- *Part 2: Combustion/titration method*
- *Part 3: Combustion/infrared method*

Introduction

This part of ISO 4689 is a new procedure. ISO 4689-2 was originally published as ISO 4690:1986. Under a policy of rationalization of the numbering system used in ISO/TC 102, it has been decided to re-designate ISO 4690:1986 as ISO 4689-2. It was further decided to introduce a combustion/infrared method, numbered ISO 4689-3, i.e. this part of ISO 4689.

When next revised, ISO 4689:1986 will be re-designated as ISO 4689-1.

iTeh STANDARD PREVIEW
(standards.iteh.ai)

[ISO 4689-3:2015](https://standards.iteh.ai/catalog/standards/sist/4B808d5-c969-4514-8135-16e0f72e91B/iso-4689-3-2015)

<https://standards.iteh.ai/catalog/standards/sist/4B808d5-c969-4514-8135-16e0f72e91B/iso-4689-3-2015>

iTeh STANDARD PREVIEW
(standards.iteh.ai)

ISO 4689-3:2015

<https://standards.iteh.ai/catalog/standards/sist/4B808d5-c969-4514-8135-16e0f72e91B/iso-4689-3-2015>

Iron ores — Determination of sulfur content —

Part 3: Combustion/infrared method

WARNING — This part of ISO 4689 may involve hazardous materials, operations, and equipment. This part of ISO 4689 does not purport to address all of the safety problems associated with its use. It is the responsibility of the user of this part of ISO 4689 to establish appropriate health and safety practices and determine the applicability of regulatory limitations prior to use.

1 Scope

This part of ISO 4689 specifies a combustion/infrared method, using a high-frequency induction furnace, for the determination of the sulfur content of iron ores.

This method is applicable to sulfur contents between 0,002 % (mass fraction) and 0,25 % (mass fraction) in natural iron ores, iron ore concentrates and agglomerates, including sinter products. The method is not applicable to iron ores containing more than 1,0 % (mass fraction) of combined water. The apparatus, of which the metal filter is equipped with a heating device, can be applied to iron ores containing less than 3,0 % (mass fraction) of combined water.

2 Normative references

The following documents, in whole or in part, are normatively referenced in this document and are indispensable for its application. For dated references, only the edition cited applies. For undated references, the latest edition of the referenced document (including any amendments) applies.

ISO 648, *Laboratory glassware — Single-volume pipettes*

ISO 1042, *Laboratory glassware — One-mark volumetric flasks*

ISO 3082, *Iron ores — Sampling and sample preparation procedures*

ISO 7764, *Iron ores — Preparation of predried test samples for chemical analysis*

ISO Guide 35, *Reference materials — General and statistical principles for certification*

3 Principle

The sample is mixed with a flux containing iron, tin, and tungsten and heated in a high-frequency induction furnace, using oxygen as a supporting fuel and carrier gas.

The evolved sulfur dioxide is carried by oxygen into the cell of an infrared detector, where the absorption scale is read.

4 Reagents

During analysis, use only reagents of recognized analytical grade, and only distilled water or water of equivalent purity.

4.1 Metallic iron, particle size 0,2 mm to 1,2 mm containing less than sulfur.

- 4.2 **Magnesium perchlorate**, $Mg(ClO_4)_2$, anhydrous, free flowing, particle size 0,5 mm to 2 mm.
- 4.3 **Iron(III) oxide**, containing less than 0,003 % sulfur.
- 4.4 **Metallic tin**, particle size 0,2 mm to 1,2 mm containing less than 0,001 % sulfur.
- 4.5 **Metallic tungsten**, particle size 0,2 mm to 1,2 mm containing less than 0,001 % sulfur.
- 4.6 **Sodium hydroxide coated silica**, particle size 0,5 mm to 2 mm.
- 4.7 **Sodium hydroxide**, particle size 0,5 mm to 2 mm.
- 4.8 **Standard sulfur solution**, prepared as follows.

Dry 8 g of potassium sulfate (purity >99,99 % [mass fraction]) to constant mass at 105 °C to 110 °C and cool in a desiccator. Weigh the dried masses of potassium sulfate specified in [Table 1](#) and dissolve each portion in water. Cool, transfer each portion to separate 100 ml volumetric flasks and dilute to volume with water.

Table 1 — Sulfur standard solution (calibration series)

Solution No.	Mass of potassium sulfate g	Concentration of sulfur mg/ml
1	0,543 5	1,00
2	1,087 0	2,00
3	1,902 2	3,50
4	2,717 4	5,00

5 Apparatus

Ordinary laboratory apparatus, including one-mark pipettes and one-mark volumetric flasks complying with the specifications of ISO 648 and ISO 1042 respectively, as well as the following.

- 5.1 **Oxygen supply**.
- 5.2 **Absorption tower**, containing sodium hydroxide coated silica ([4.6](#)) or sodium hydroxide ([4.7](#)).
- 5.3 **Drying tower**, containing magnesium perchlorate ([4.2](#)).
- 5.4 **High-frequency induction furnace**, having a heating induction coil (height 30 mm to 55 mm, 4 to 5 rolls), capable of heating to a temperature of 1 200 °C.
An example of a combustion furnace, with combustion gas-refining section, is given in [Figure 1](#).
- 5.5 **Combustion tube**, quartz.
- 5.6 **Refractory combustion crucible**.

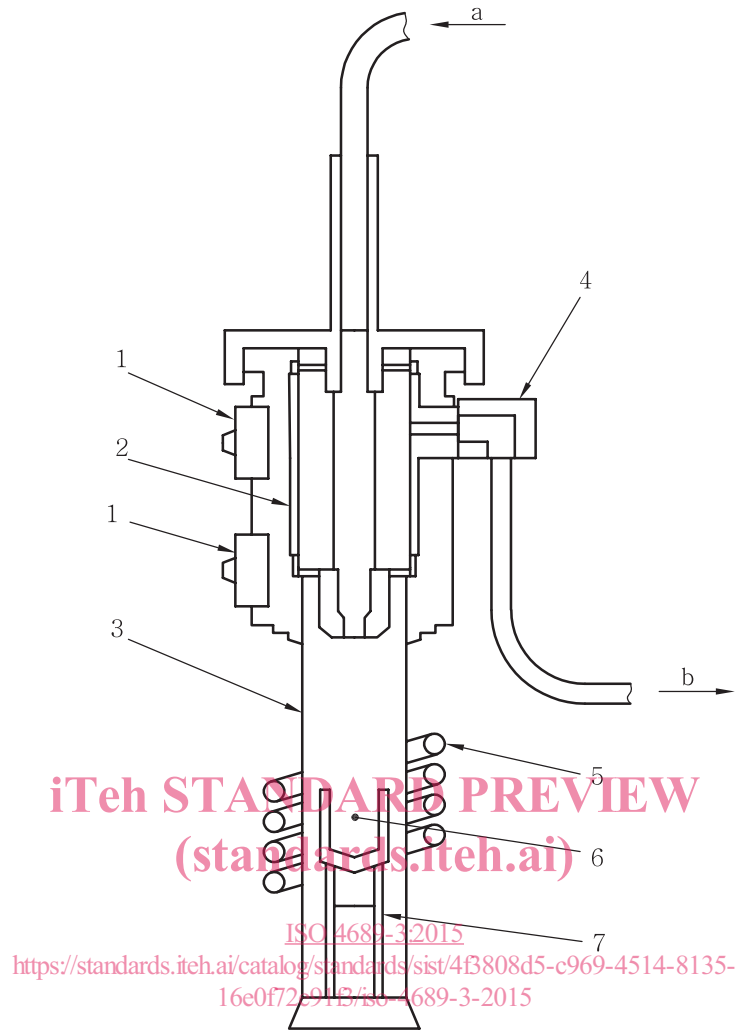
**Key**

- 1 metal filter
- 2 heating device
- 3 quartz combustion tube
- 4 dust trap
- 5 high-frequency induction coil
- 6 crucible
- 7 holder
- a Oxygen.
- b Combustion gas.

Figure 1 — Example of combustion furnace with combustion gas-refining section

5.7 Tin capsule.

The following dimensions may be used as guidelines.

Combustion tube		Combustion crucible		Tin capsule	
Length	140 mm to 220 mm	Length	26 mm	Diameter	6 mm
Outer diameter	30 mm to 44 mm	Outer diameter	10 mm	Height	18 mm
Inner diameter	26 mm to 37 mm	Inner diameter	26 mm	Mass	0,3 g
				Volume	0,4 ml

5.8 Metal filter.

5.9 Dust trap, containing glass wool.

5.10 Detector for infrared absorption, an example of which is shown in Figure 2.

5.11 Micro-pipette, capacity 100 µl, accurate to 1µl.

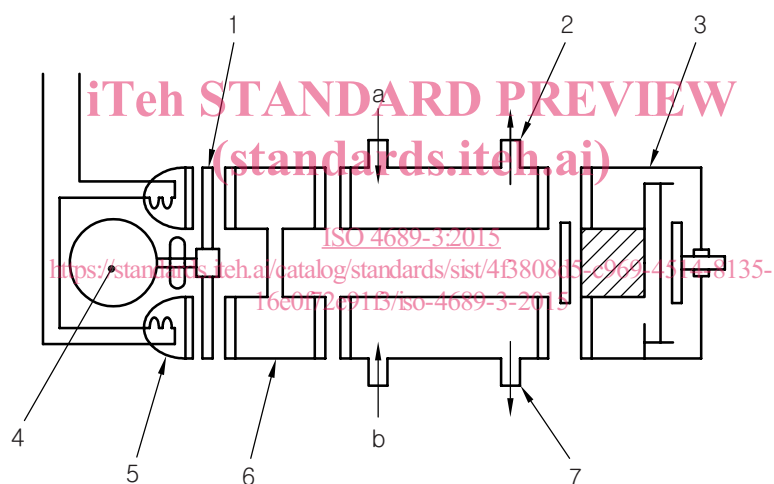

- Key**
- 1 chopper
 - 2 measuring cell
 - 3 infrared detector
 - 4 motor
 - 5 infrared source
 - 6 filter cell
 - 7 reference cell
 - a Combustion gas.
 - b Oxygen.

Figure 2 — Example of an infrared detection system

6 Sampling and samples

6.1 Laboratory sample

For analysis, use a laboratory sample of $-100\ \mu\text{m}$ particle size which has been taken and prepared in accordance with ISO 3082. In the case of ores having significant contents of combined water or oxidizable compounds, use a particle size of $-160\ \mu\text{m}$.

NOTE A guideline on significant contents of combined water and oxidizable compounds is incorporated in ISO 7764.

6.2 Preparation of predried test samples

Thoroughly mix the laboratory sample and, taking multiple increments, extract a test sample in such a manner that it is representative of the entire contents of the container. Dry the test sample at $105\ \text{°C} \pm 2\ \text{°C}$ as specified in ISO 7764. This is the predried test sample.

7 Procedure

7.1 Number of determinations

Carry out the analysis at least in duplicate in accordance with [Annex A](#), independently, on one predried test sample.

NOTE The expression “independently” means that the second and any subsequent result is not affected by the previous result(s). For this particular analytical method, this condition implies that the repetition of the procedure is carried out either by the same operator at a different time or by a different operator, including in either case, appropriate recalibration.

ISO 4689-3:2015

<https://standards.iteh.ai/catalog/standards/sist/4f3808d5-c969-4514-8135-16e0f72e91f3/iso-4689-3-2015>

7.2 Test portion

Taking several increments, weigh to the nearest 0,000 2 g, approximately 0,5 g of the predried test sample obtained in accordance with [6.2](#). For samples containing in excess of 0,1 % (mass fraction), sulfur should be taken.

The test portion should be taken and weighed quickly to avoid re-absorption of moisture.

7.3 Blank test and check test

In each run, one blank test and one analysis of a certified reference material of the same type of ore shall be carried out in parallel with the analysis of the ore sample(s) under the same conditions. A predried test sample of the certified reference material shall be prepared as specified in [6.2](#).

The certified reference material should be of the same type as the sample to be analysed and the properties of the two materials should be sufficiently similar to ensure that in either case no significant changes in the analytical procedure will become necessary.

Where the analysis is carried out on several samples at the same time, the blank value may be represented by one test, provided that the procedure is the same and the reagents are from the same reagent bottles.

Where the analysis is carried out on several samples of the same type of ore at the same time, the analytical value of one certified reference material may be used.