



SLOVENSKI STANDARD
oSIST prEN 12543-2:2019

01-junij-2019

Neporušitvene preiskave - Značilnosti goriščne površine v industrijskih rentgenskih sistemih za neporušitveno preskušanje - 2. del: Metoda s kamero z luknjico

Non-destructive testing - Characteristics of focal spots in industrial X-ray systems for use in non-destructive testing - Part 2: Pinhole camera radiographic method

Zerstörungsfreie Prüfung - Charakterisierung von Brennflecken in Industrie-Röntgenanlagen für die zerstörungsfreie Prüfung - Teil 2: Radiographisches Lochkamera-Verfahren

Essais non destructifs - Caractéristiques des foyers émissifs des tubes radiogènes industriels utilisés dans les essais non destructifs - Partie 2 : Méthode radiographique par sténopé

Ta slovenski standard je istoveten z: prEN 12543-2

ICS:

19.100 Neporušitveno preskušanje Non-destructive testing

oSIST prEN 12543-2:2019

en,fr,de

iTeh STANDARD PREVIEW
(standards.iteh.ai)

[kSIST FprEN 12543-2:2021](#)

<https://standards.iteh.ai/catalog/standards/sist/f3674dfb-c326-4347-8698-e6e470e07097/ksist-fpren-12543-2-2021>

EUROPEAN STANDARD
NORME EUROPÉENNE
EUROPÄISCHE NORM

DRAFT
prEN 12543-2

April 2019

ICS 19.100

Will supersede EN 12543-2:2008

English Version

Non-destructive testing - Characteristics of focal spots in industrial X-ray systems for use in non-destructive testing - Part 2: Pinhole camera radiographic method

Essais non destructifs - Caractéristiques des foyers émissifs des tubes radiogènes industriels utilisés dans les essais non destructifs - Partie 2 : Méthode radiographique par sténopé

Zerstörungsfreie Prüfung - Charakterisierung von Brennflecken in Industrie-Röntgenanlagen für die zerstörungsfreie Prüfung - Teil 2: Radiographisches Lochkamera-Verfahren

This draft European Standard is submitted to CEN members for enquiry. It has been drawn up by the Technical Committee CEN/TC 138.

If this draft becomes a European Standard, CEN members are bound to comply with the CEN/CENELEC Internal Regulations which stipulate the conditions for giving this European Standard the status of a national standard without any alteration.

This draft European Standard was established by CEN in three official versions (English, French, German). A version in any other language made by translation under the responsibility of a CEN member into its own language and notified to the CEN-CENELEC Management Centre has the same status as the official versions.

CEN members are the national standards bodies of Austria, Belgium, Bulgaria, Croatia, Cyprus, Czech Republic, Denmark, Estonia, Finland, Former Yugoslav Republic of Macedonia, France, Germany, Greece, Hungary, Iceland, Ireland, Italy, Latvia, Lithuania, Luxembourg, Malta, Netherlands, Norway, Poland, Portugal, Romania, Serbia, Slovakia, Slovenia, Spain, Sweden, Switzerland, Turkey and United Kingdom.

Recipients of this draft are invited to submit, with their comments, notification of any relevant patent rights of which they are aware and to provide supporting documentation.

Warning : This document is not a European Standard. It is distributed for review and comments. It is subject to change without notice and shall not be referred to as a European Standard.



EUROPEAN COMMITTEE FOR STANDARDIZATION
COMITÉ EUROPÉEN DE NORMALISATION
EUROPÄISCHES KOMITEE FÜR NORMUNG

CEN-CENELEC Management Centre: Rue de la Science 23, B-1040 Brussels

Contents	Page
European foreword	3
Introduction	4
1 Scope	5
2 Normative references	5
3 Terms and definitions	5
4 Test equipment	6
4.1 Essential characteristics of the pinhole	6
4.2 Alignment and position of the pinhole camera	7
4.3 Position of the radiographic image detector	7
4.4 Requirements on the radiographic image detector	9
4.5 Image processing equipment	9
4.6 Loading factors	10
5 Measurement and determination of the focal spot size	10
5.1 Measurement procedure	10
5.2 Measurement with digital technique (preferred method)	11
5.3 Evaluation with digital technique using Integrated Line Profiles (ILP)	12
5.4 Measurement of effective focal spot size visually using film radiographs	14
6 Classification and result of focal spot size measurement	15
Annex A (informative) Values for the classification of X-ray tube focal spot sizes	16
Bibliography	18

European foreword

This document (prEN 12543-2:2019) has been prepared by Technical Committee CEN/TC 138 “Non-destructive testing”, the secretariat of which is held by AFNOR.

This document is currently submitted to the CEN Enquiry.

This document will supersede EN 12543-2:2008.

iTeh STANDARD PREVIEW (standards.iteh.ai)

[kSIST FprEN 12543-2:2021](https://standards.iteh.ai/catalog/standards/sist/f3674dfb-c326-4347-8698-e6e470e07097/ksist-fpren-12543-2-2021)

<https://standards.iteh.ai/catalog/standards/sist/f3674dfb-c326-4347-8698-e6e470e07097/ksist-fpren-12543-2-2021>

prEN 12543-2:2019 (E)**Introduction**

In order to cover the large range of effective focal spot sizes, four different methods are described in EN 12543-2, EN 12543-4, EN 12543-5 and prEN 12543-6.

The pinhole method (EN 12543-2) is intended for effective focal spot sizes above 50 μm and mainly sealed standard- and mini focus tubes.

The penetrometer method of EN 12543-4 is intended for field applications when the users have to observe the effective focal spot on a regular basis and the pinhole method is non-practical.

The edge measurement method of EN 12543-5 is intended for measurement of effective focal spot sizes between 5 μm and 300 μm and mainly for the use with μ -Focus tubes (up to 100 μm) and mini focus tubes with spot sizes of 100 μm to 300 μm .

In the overlapping ranges, the different standard parts provide comparable values within $\pm 20\%$ tolerance.

ASTM E1165 describes the same procedure.

iTeh STANDARD PREVIEW (standards.iteh.ai)

[kSIST FprEN 12543-2:2021](https://standards.iteh.ai/catalog/standards/sist/f3674dfb-c326-4347-8698-e6e470e07097/ksist-fpren-12543-2-2021)

<https://standards.iteh.ai/catalog/standards/sist/f3674dfb-c326-4347-8698-e6e470e07097/ksist-fpren-12543-2-2021>

1 Scope

This document specifies a method for the measurement of effective focal spot dimensions above 0,1 mm of X-ray systems up to and including 1000 kV tube voltage by means of the pinhole camera method with digital evaluation. The tube voltage applied for this measurement is restricted to 200 kV for visual film evaluation.

The imaging quality and the resolution of X-ray images depend highly on the characteristics of the effective focal spot, in particular the size and the two dimensional intensity distribution as seen from the detector plane.

This test method provides instructions for determining the effective size (dimensions) of standard (macro focal spots) and mini focal spots of industrial X-ray tubes. This determination is based on the measurement of an image of a focal spot that has been radiographically recorded with a "pinhole" technique and evaluated with a digital method.

For the characterization of commercial X-ray tube types (i.e. for advertising or trade) it is advised that the specific FS values of Annex A are used.

2 Normative references

The following documents are referred to in the text in such a way that some or all of their content constitutes requirements of this document. For dated references, only the edition cited applies. For undated references, the latest edition of the referenced document (including any amendments) applies.

EN ISO 19232-5, *Non-destructive testing – Image quality of radiographs – Part 5: Determination of the image unsharpness and basic spatial resolution value using duplex wire-type image quality indicators (ISO 19232-5)*

[kSIST FprEN 12543-2:2021](https://www.iso.org/standards/catalog/standards/sist/f3674dfb-c326-4347-8698-e6e470e07097/ksist-fpren-12543-2-2021)

3 Terms and definitions

For the purposes of this document, the following terms and definitions apply.

ISO and IEC maintain terminological databases for use in standardization at the following addresses:

- IEC Electropedia: available at <http://www.electropedia.org/>
- ISO Online browsing platform: available at <http://www.iso.org/obp>

3.1

actual focal spot

X-ray producing area of the target as viewed from a position perpendicular to the target surface (see Figure 3)

Note 1 to entry: The actual focal spot is also called thermal focal spot in other literature.

3.2

effective focal spot

X-rays producing area of the target as viewed from the image plane of the detector (see Figure 3)

3.3

effective size of focal spot

focal spot size measured in accordance with this document

prEN 12543-2:2019 (E)

3.4

basic spatial resolution of a detector $SR_{b, \text{detector}}$

smallest degree of visible detail within a digital image, determined with the duplex wire IQI according to EN ISO 19232-5 located on the detector (magnification = 1), from the smallest number of the duplex wire pair with less than 20% modulation depth in a linearized profile and it corresponds to $\frac{1}{2}$ of the detector image unsharpness

4 Test equipment**4.1 Essential characteristics of the pinhole**

The pinhole camera shall consist of a diaphragm with a pinhole having following essential dimensions P and H according to Table 1 dependent from the actual focal spot size.

Table 1 — Dimensions of the pinhole

Focal spot size	Diameter P	Height H
mm	μm	μm
0,1 to 0,3	10 ± 5	50 ± 5
> 0,3 to 1,0	30 ± 5	75 ± 10
> 1,0	100 ± 5	500 ± 10

The essential dimensions P and H are shown in Figure 1.

<https://standards.iteh.ai/catalog/standards/sist/b3674dfb-c326-4347-8668-e6e470e07097/ksist-fpren-12543-2-2021> Dimensions in millimetres

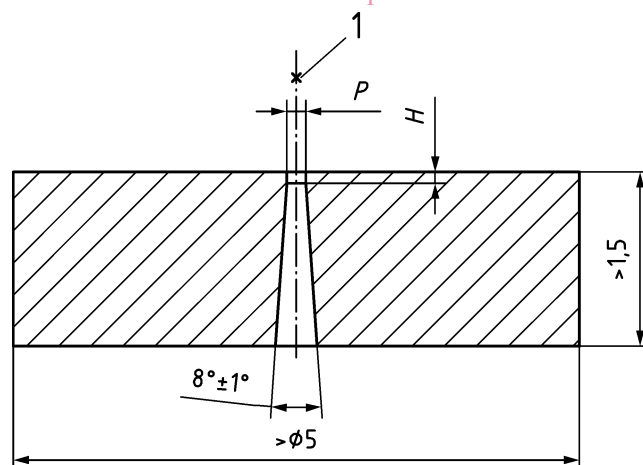
**Key**

1 focal spot

Figure 1 — Essential dimensions of a pinhole diaphragm

The pinhole diaphragm shall be made of tungsten or of a similar absorbent material.

4.2 Alignment and position of the pinhole camera

The angle between the beam direction and the pinhole axis (see Figure 2) shall be smaller than $\pm 1,5^\circ$. When deviating from Figure 2, the direction of the beam shall be indicated.

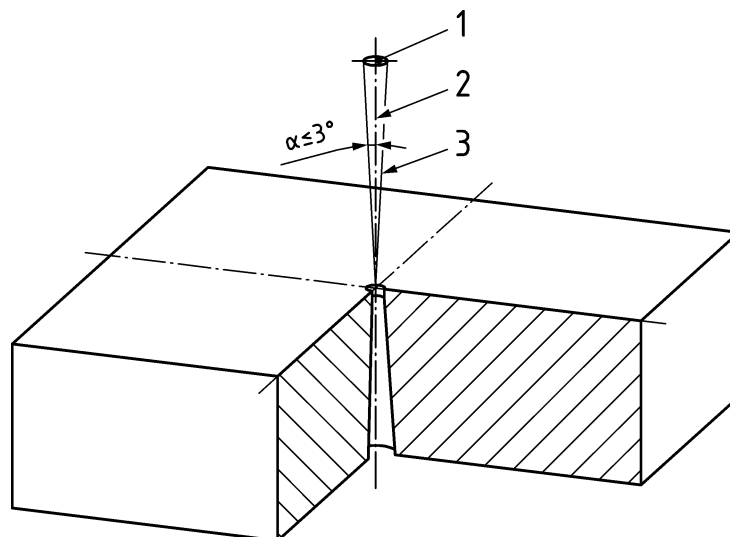

Key

- 1 focal spot
- 2 beam direction
- 3 maximum deviation of the axis of the pinhole

iTeh STANDARD PREVIEW
(standards.iteh.ai)

Figure 2 — Alignment of the pinhole camera

<https://standards.iteh.ai/catalog/standards/sist/b3674dfb-c326-4347-8698-664170a07097/sist-prn-12543-2-2021>

The incident face of the pinhole diaphragm shall be placed at a distance m from the focal spot so that the variation of the magnification over the extension of the actual focal spot does not exceed $\pm 5\%$ in the beam direction. In no case shall this distance be less than 100 mm.

4.3 Position of the radiographic image detector

The radiographic image detector (film, imaging plate or DDA) shall be placed normal to the beam direction at a distance n from the incident face of the pinhole diaphragm determined from the applicable magnification according to Figure 3 and Table 2.

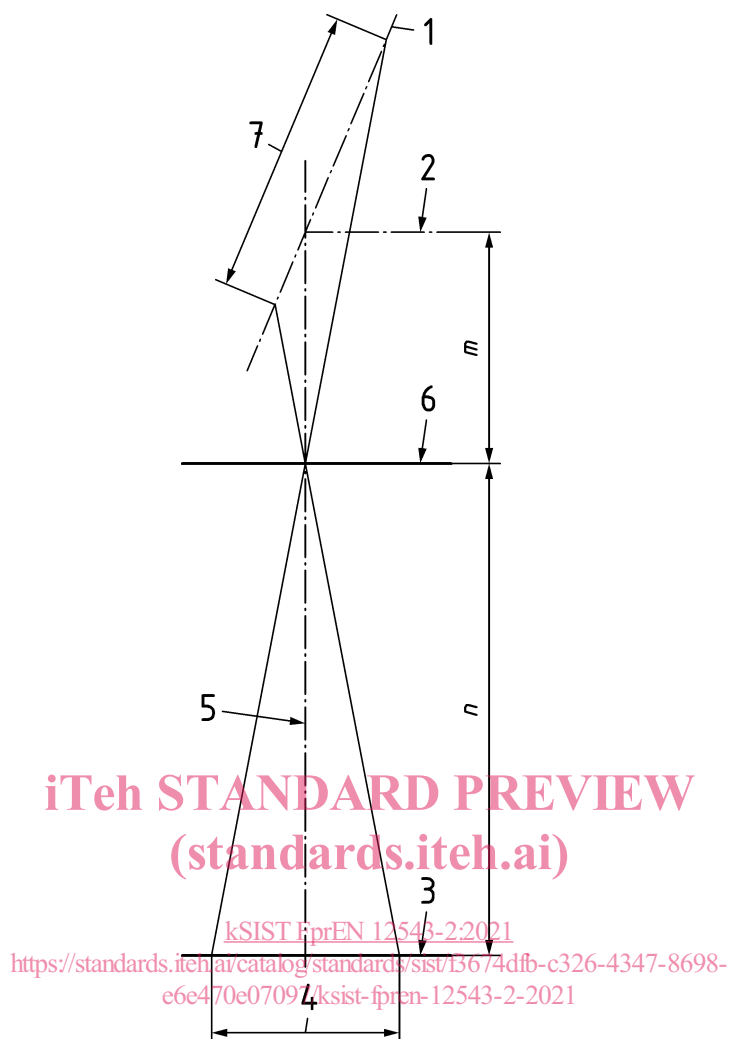
**Key**

- 1 plane of anode
- 2 reference plane
- 3 radiographic image detector
- 4 magnified length of the effective focal spot
- 5 beam direction
- 6 incident face of the diaphragm
- 7 physical length of the actual focal spot

Figure 3 — Beam direction dimensions and planes

Table 2 — Magnification for focal spot pinhole images

Anticipated Focal Spot Size d	Minimum Magnification	Distance between Focal Spot and Pinhole m	Distance between Pinhole and Detector n
[mm]	n/m	[m] ^a	[m] ^a
0,1 to 2,0	3: 1	0,25	0,75
> 2,0	1: 1	0,5	0,5

^a When using a technique that entails the use of enlargement factors and a 1 m focal spot to detector distance (FDD = m+n) is not possible (see 7.1), the distance between the focal spot and the pinhole (m) shall be adjusted to suit the actual focal spot to detector distance (FDD) used (for example, if a 600 mm FDD is used, m shall be 150 mm for 3:1 enlargement, 300 mm for 1:1 enlargement, and the like).

4.4 Requirements on the radiographic image detector

Analogue or digital radiographic image detectors can be used, provided sensitivity, dynamic range and detector unsharpness allow capturing of the full spatial size of the focal spot image without detector saturation. The maximum allowed basic spatial resolution (SR_b^{detector}) of the detector is determined from the pinhole diameter P and magnification n/m. It is calculated according to Formula (1).

$$SR_b^{\text{detector}} = \frac{P}{2} \cdot \left(1 + \frac{n}{m} \right) \quad (1)$$

The basic spatial resolution of the detector (SR_b^{detector}) shall be determined with the duplex wire IQI according to EN ISO 19232-5. For correct quantitative measurements the minimum projected length and width of the focal spot image should be covered always by at least the pixel number which is equivalent to $20 \times SR_b^{\text{detector}}$. The signal-to-noise ratio of the focal spot image (ratio of the maximum intensity value inside the focal spot and the standard deviation of the background signal outside) should be at least 70. The maximum intensity inside the focal spot should be above 30 %, but lower than 90 % of the maximum linear detector output value. The grey value resolution of the detector shall be at least 12 bit.

Imaging plate systems (Computed Radiography, CR) or digital detector arrays (e.g. based on CCD-, amorphous-Si- or CMOS-detectors coupled to an X-ray fluorescence screen, or direct converting detectors) may be used as digital image detectors. The pixel values (grey values) shall be linear to the dose.

If radiographic film is used as image detector, it should meet the requirements of the film system class C 4 or better according to ISO 11699-1 and shall be used without screens. The film shall be exposed to a maximum optical density between 1.5 and 2.5. The film shall be digitized with a maximum pixel size of 50 μm or a smaller size, which shall fulfil the requirements of the above SR_b^{detector} condition and be evaluated according to 5.1. If the user has no digital equipment the film may be evaluated visually; the procedure is shown in 5.4. The visual evaluation of film radiographs will be less accurate than the evaluation of digital images with the profile function as described in 5.3.

4.5 Image processing equipment

This apparatus is used to capture the images and to measure the intensity profile of the focal spot in the projected image. The image shall be a positive image (more X-ray dose shows higher grey values) and linear proportional to the dose.

The equipment shall be able: