



Designation: ~~E636-02~~ Designation: E 636 - 09

Standard Guide for Conducting Supplemental Surveillance Tests for Nuclear Power Reactor Vessels, E 706 (IH)¹

This standard is issued under the fixed designation E 636; the number immediately following the designation indicates the year of original adoption or, in the case of revision, the year of last revision. A number in parentheses indicates the year of last reapproval. A superscript epsilon (ϵ) indicates an editorial change since the last revision or reapproval.

1. Scope

~~1.1~~ 1.1 This guide discusses test procedures that can be used in conjunction with, but not as alternatives to, those required by Practices E 185 and E 2215 for the surveillance of nuclear reactor vessels. The supplemental mechanical property tests outlined permit the acquisition of additional information on radiation-induced changes in fracture toughness, notch ductility, and tensile yield strength properties of the reactor vessel steels.

1.2 This guide provides recommendations for the preparation of test specimens for irradiation, and identifies special precautions and requirements for reactor surveillance operations and postirradiation test planning. Guidance on data reduction and computational procedures is also given. Reference is made to other ASTM and ISO test methods for the physical conduct of specimen tests and for raw data acquisition.

2. Referenced Documents

2.1 ASTM Standards:

~~E 8~~ Test Methods for Tension Testing of Metallic Materials²

~~E 23~~ Test Methods for Notched Bar Impact Testing of Metallic Materials²

~~E 184~~ Practice for Effects of High-Energy Neutron Radiation on the Mechanical Properties of Metallic Materials, E706 (IB)-Test Methods for Notched Bar Impact Testing of Metallic Materials

~~E 185~~ Practice for Conducting Surveillance Tests for Light-Water Cooled Nuclear Power Reactor Vessels, E706 (IF)³-Practice for Design of Surveillance Programs for Light-Water Moderated Nuclear Power Reactor Vessels

~~E 399~~ Test Method for Plane-Strain Fracture Toughness of Metallic Materials²

~~E 482~~ Guide for Application of Neutron Transport Methods for Reactor Vessel Surveillance, E706 (HD)³

~~E 560~~ Practice for Extrapolating Reactor Vessel Surveillance Dosimetry Results, E706 (IC)³

~~E 616~~ Terminology Relating to Fracture Testing²

~~E 706~~ Master Matrix for Light-Water Reactor Pressure Vessel Surveillance Standards, E706 (O)³

~~E 1221~~ Test Method for Determining Plane-Strain Crack-Arrest Fracture Toughness, K_{Ia} , of Ferritic Steels²-Test Method for Linear-Elastic Plane-Strain Fracture Toughness K_{Ic} of Metallic Materials

~~E 1253~~ Guide for Reconstitution of Irradiated Charpy-Sized Specimens

~~E 1820~~ Test Method for Measurement of Fracture Toughness

~~E 1921~~ Test Method for Determination of Reference Temperature, T_0 , for Ferritic Steels in the Transition Range³-Test Method for Determination of Reference Temperature, T_0 , for Ferritic Steels in the Transition Range

~~E 2215~~ Practice for Evaluation of Surveillance Capsules from Light-Water Moderated Nuclear Power Reactor Vessels

2.2 Other Standards:

ASME Boiler and Pressure Vessel Code, Section III; Subsection NB (Class 1 Components)³

ISO 14556 Steel Charpy V-notch Pendulum Impact Test- Instrumented Test Method⁴

¹ This guide is under the jurisdiction of ASTM Committee E10 on Nuclear Technology and Applications and is the direct responsibility of Subcommittee E10.02 on Behavior and Use of Nuclear Structural Materials.

Current edition approved June 10, 2002. Published September 2002. Originally published as E636-83. Last previous edition E636-95.

Current edition approved Feb. 1, 2009. Published March 2009. Originally approved in 1983. Last previous edition approved in 2002 as E 636 - 02.

² For referenced ASTM standards, visit the ASTM website, www.astm.org, or contact ASTM Customer Service at service@astm.org. For *Annual Book of ASTM Standards* volume information, refer to the standard's Document Summary page on the ASTM website.

³ Annual Book of ASTM Standards, Vol 12.02.

³ Available from American Society of Mechanical Engineers, 345 E. 47th St., New York, NY 10017.

⁴ Available from American Society of Mechanical Engineers, 345 E. 47th St., New York, NY 10017.

⁴ Available from International Organization for Standardization (ISO), 1 rue de Varembe, Case postale 56, CH-1211, Geneva 20, Switzerland.

3. Significance and Use

3.1 Practices E 185 describes and E 2215 describe a minimum program for the surveillance of reactor vessel materials, specifically mechanical property changes that occur in service. Guide E 636 This guide may be applied in order to generate additional specific fracture toughness property information on radiation-induced property changes to better assist the determination of the optimum reactor vessel operation schemes.

4. Supplemental Mechanical Property Test

4.1 *Fracture Toughness Test*—This test involves the dynamic or static testing of a fatigue-precracked specimen during which a record of force versus displacement is used to determine material fracture toughness properties such as the plane strain fracture toughness (K_{Ic}), the J -integral fracture toughness (J_{Ic}), the J - R curve, and the reference temperature (T_0) (see Test Methods E 399, E 1820, and E 1921 E 399, E 1820, and E 1921, respectively). These test methods generally apply to elastic, elastic-plastic, ductile-to-brittle transition, or fully plastic behavior. The rate of specimen loading or stress intensity increase required for test classification as quasi-static or dynamic is indicated by the referenced test methods. Presently, only Test Methods E 399 and E 1820 All three test methods specify a lower limit on loading rate for dynamic test performed in the linear elastic regime. tests.

4.2 *Precracked Charpy Fracture Toughness Test at Impact Test Loading Rates*—This test involves impact testing of Charpy V-notch specimens that have been fatigue precracked. A force versus deflection or time record, or both, are is obtained during the test to determine an estimate of material dynamic fracture toughness properties. The test method applies to the brittle/ductile transition region. Currently, no standard test method is available for performing and analyzing this test; details on the recommended procedures are given in 7.1– 7.4 and Appendix Appendix X1.

4.3 *Instrumented Charpy V-Notch Test*—This test involves the impact testing of standard Charpy V-notch specimens using a conventional tester (Test Methods E 23) equipped with supplemental instrumentation that provides a load force versus deflection or time record, or both, to augment standard test data (ISO 145556). The test record is used primarily to estimate dynamic yield stress, fracture initiation and propagation energies, and to identify fully ductile (upper shelf) fracture behavior.

4.4 Other mechanical property tests-s not covered by ASTM standards, for example, miniature, nondestructive, nonintrusive, or in-situ testing techniques, can be utilized to accommodate limitations of material availability or irradiation facility configuration, or both. However, the user should establish the method's technical validity and correlation with existing test methods.

5. General Test Requirements

5.1 *Specimen Orientation and Preparation* :

5.1.1 *Orientation*— It is recommended that specimens for supplemental surveillance testing be taken from the quarter thickness location of plate and forging materials, as defined in NB 2300 of ASME Boiler and Pressure Vessel Code, Section III, and at a distance at least one material thickness from a quenched edge. Specimens from near surface material also may be considered for special studies, if required. For weld deposits, it is recommended that the specimens be taken from a thickness location at least 12.7 mm (½ in.) removed from the root and the surfaces of the weld. Consistent with Practice E 185, it is further recommended that the specimens be oriented to represent the transverse orientation (T-L, per Test Method E 399) in plate and forging materials. Specimens having the longitudinal orientation (L-T, per Test Method E 399) also may be used given sufficient material and space in the surveillance capsule. For weld deposits, the specimen shall be oriented to make the plane of fracture parallel to the welding direction and perpendicular to the weldment surface, with the direction of crack growth along the welding direction. Examples of specimen orientations are given in Fig. 1.

5.1.1.1 *Specimen Notch Orientation* —The specimen notch root in all cases shall be oriented normal to the plate, forging, or weldment surface. For weld deposits, the notch also should be located at the approximate weld deposit centerline. The centerline and the width of the weld deposit about the notch shall be determined from the weld fusion lines revealed by etching. It is recommended that the location of the weld fusion lines be permanently marked for reference for post-irradiation testing. The general appearance of the etched weld deposit in terms of individual weld bead size (large vs. small) and the number of weld beads across the weld deposit should be determined and recorded.

5.1.1.2 *Specimen Marking*— A suitable specimen identification, marking, and documentation system shall be used whereby the location and orientation of each specimen within the source plate, forging, or weldment can be traced. The traceability of weld specimens is particularly important because of the possibility for variations through the weldment thickness.

5.1.2 *Preparation*— All specimens shall be prepared from material that has been fully heat-treated, including stress-relief annealing, as recommended in Practice E 185.

5.1.2.1 *Reconstitution*—If reconstituted specimens are to be used, the procedures outlined in Guide E 1253 shall be followed for Charpy-sized specimens. For other specimen geometries, it must have been previously proven that the reconstitution procedure has no significant influence on the fracture toughness test result.

5.1.2.2 *Machining*—Specimens for irradiation should be finish machined on all sides to aid encapsulation in reactor experiments and to aid radiation temperature control and uniformity.

5.1.2.3 *Fatigue Precracking*—It is recommended that fatigue precracking of specimens, if required, should specimens be accomplished prior to irradiation to avoid difficulties of precracking following irradiation. However, fatigue precracking of a specimen following irradiation is acceptable if a suitable means of following crack extension in the specimen is established.

5.1.2.4 *Fatigue Precracking of Postirradiation Heat-Treated Specimens*—Some postirradiation heat treatments at temperatures

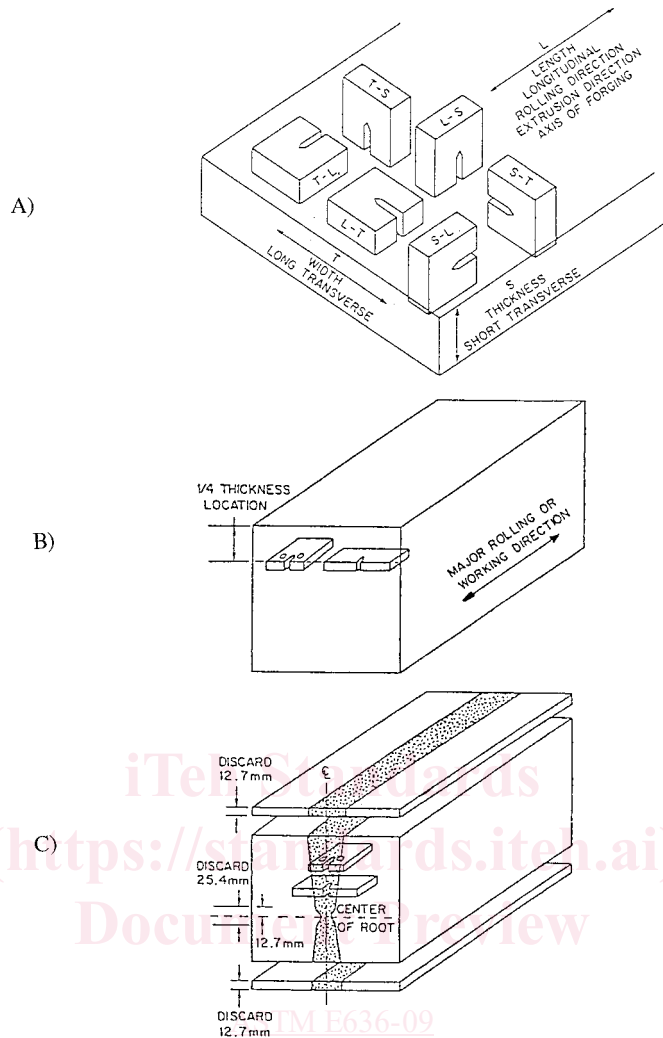

FIG. 1 Specimen Orientation and Location in Plate, Forging, and Weld Deposit Materials: A) Crack Plane Orientation Code; B) Plate and Forging Specimen Location and Orientation; C) Weld Specimen Location and Orientation

higher than the prior irradiation exposure can cause mechanical property recovery, including reductions in yield strength and tensile strength and an improvement in fracture toughness toward preirradiation levels. Compliance with Test Methods E 399, E 1820, and E1921, E 1921 requires that fatigue precracking be accomplished in the final heat treatment condition. This may be impractical for irradiated specimens. Fatigue precracking before postirradiation heat treatment is acceptable for low temperature heat treatment typical of reactor vessel annealing. It is believed that heat treatments fatigue precracking of ferritic material specimens prior to heat treatment below 482°C (900°F) does not alter the test results and that for the fatigue precracked tests represent the bulk material properties as intended.

5.2 Specimen Irradiation:

5.2.1 *General*—The recommendations of Practice E 185 concerning the encapsulation of specimens, temperature and neutron fluence monitoring, and irradiation exposure conditions should be followed. The larger size of some supplemental test specimens may require additional consideration of temperature gradients and neutron flux gradients within individual specimens and within the specimen capsules.

5.2.2 *Specimen Irradiation*—Supplemental test specimens may be irradiated in the same capsule as the specimens required by Practice E 185 when supplemental results are desired.

5.3 Specimen Handling and Remote Test Equipment:

5.3.1 *General*—For testing in a controlled area or in a hot cell facility, remote devices for accurately positioning the specimen in the test machine are generally required. For notched or precracked Charpy impact specimens, automatic devices to position the specimen on the test anvils are strongly recommended. Additional remote devices for specimen heating and cooling and for the attachment of measuring fixtures are also necessary. Remote testing equipment shall satisfy the tolerances and accuracy requirements of the applicable ASTM standards for the test method(s) employed.

5.4 *Specimen Testing*— It is recommended that postirradiation Charpy V-notch impact and tensile tests be performed in accordance with Practice E185E 2215 prior to supplemental specimen testing to establish a basis for selecting test temperatures for the supplemental specimens ~~provided~~tested under this method.

5.5 *Documentation:*

5.5.1 The report shall include the reporting requirements on material identification and irradiation history required by Practice E 185. Emphasis should be placed on the reporting of tensile properties with fracture toughness test results. See 6.1.3.2).

5.5.2 Names and models of testing and monitoring equipment, and the accuracy to which they operate, will be reported. Any special modifications (for example, ~~load~~force damping equipment, etc.) to the testing equipment must be indicated. Pertinent testing procedures used also shall be reported.

5.5.3 To aid in the interpretation of these supplemental surveillance results, data developed in accordance with Practice E185E 2215, including data from reference correlation monitor material or data from other supplemental surveillance mechanical property tests, should be included in the report or should be referenced suitably.

5.5.4 If reconstituted specimens have been used, information concerning the reconstitution technique shall be given in accordance with Guide E 1253.

6. Fracture Toughness Test

6.1 *Specimen Design and Possible Modifications:*

6.1.1 *Specimen*—The compact, single-edge bend or disk-shaped compact specimen of dimensions outlined in Test Method E 399, Test Method E 1820, or Test Method E 1921, allowing for design modification (see 6.1.2) for surveillance capsules, will be used for testing.

6.1.2 *Possible Design Modification* —Modified specimens are useful when test stock or irradiation space is limited, or when gamma heating or neutron flux gradients must be minimized. An example of reconstituted Charpy-type specimen is illustrated in Fig. 2. Specimens have also been modified after irradiation to improve their measuring capabilities. For example, many early PWR pressurized water reactors (PWR) contain ~~WOL size wedge-opening loaded (WOL)~~ fracture mechanics specimens. These specimens ~~originally~~ were originally intended for testing in the brittle fracture regimen. For ductile materials, bending can occur in the loading arms of these specimens and the tests become invalid. However, techniques have been developed to make these specimens useful for testing under ductile conditions. These include extension of the fatigue precrack ~~length~~ or modification of the specimen dimensions, or both (1) . Modified specimen designs may be employed for irradiation provided that it is shown in advance that their use will not significantly diminish the accuracy of the test or alter test results; if correlations with standard specimen test results have to be employed, their justification and accuracy have to be provided.

6.1.2.1 The pinhole spacings for compact specimens recommended in Test Method E 399 and Test Methods E 1820 or E 1921 are different. However, this difference does not significantly affect the stress field at the crack tip and, therefore, either pinhole spacing is acceptable for surveillance testing (2).

6.1.3 *Fatigue Precracking*—Fatigue precracking shall be performed in accordance with either Test Method E 399, Test Method E 1820, or Test Method E 1921as discussed in 6.1.3.1-6.1.3.3.

6.1.3.1 *Elastic and Elastic-Plastic Fracture Behavior*—When testing is expected to be performed at temperatures where the specimen ultimately fractures by cleavage, the crack ~~length-to-width~~size-to-width ratio, a/W , should range between 0.45 and 0.55,

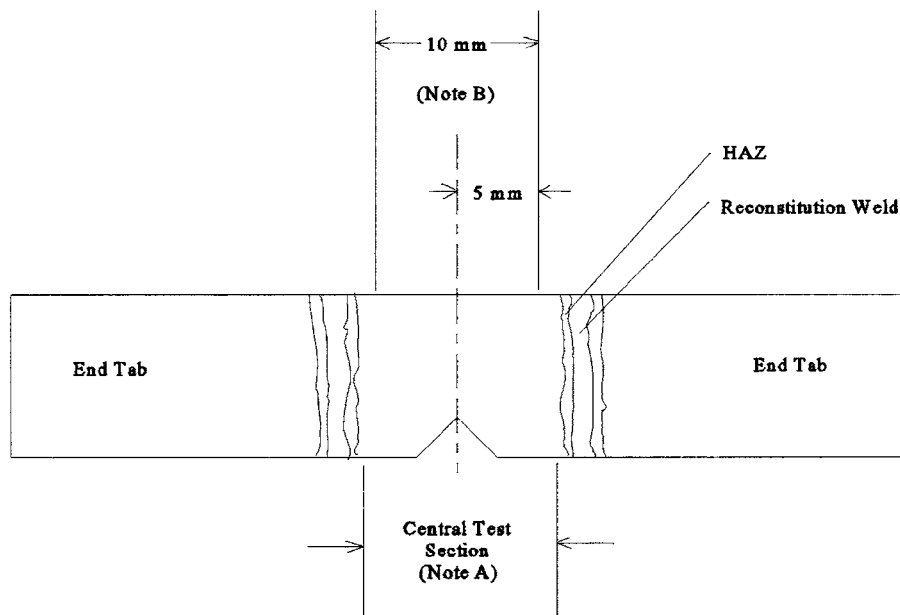

FIG. 2 Example of Reconstituted Charpy-type Specimen

and precracking should be accomplished in accordance with Test Method E 399 or Test Method E 1921.

6.1.3.2 *Fully Plastic Behavior*—When testing is expected to be performed in the region characteristic of fully plastic fracture behavior, compliance with Test Method E 1820 requires the a/W ratio to be between 0.45 and 0.70 and that the specimen thickness, B , and the initial remaining ligament, b_o , be greater than the value of $J_o/25 \sigma_{\text{flow}}$, where J_o is a provisional value of J_{Ic} , the plane-strain fracture toughness near the onset of stable crack extension, and σ_{flow} is the average of the yield strength and the tensile strength of the material at the test temperature.

6.1.3.3 *a/W ratio*—It is noted that a/W values between 0.45 and 0.55 will comply with both the requirements of Test Methods E 399 and E 1921 for testing elastic and ~~elastic-plastic~~ ductile-to-brittle transition fracture behavior (see 6.1.3.1) and Test Method E 1820 for testing fully plastic behavior (see 6.1.3.2).

6.2 *Special Requirements for Surveillance Application*—For a given neutron exposure level, the minimum number of specimens to be tested and the choice of test temperatures in relation to the expected fracture behavior are normally given in the relevant Test Methods.

NOTE 1—The specimens for characterization of elastic fracture behavior need not be of the same thickness as those required for ~~elastic-plastic~~ transition or fully plastic fracture behavior. See Test Methods ~~E 399, E 1820, and E 1921~~ E 399, E 1820, and E 1921 for size requirements.

6.2.1 *Tensile Data*—~~Yield-0.2 % offset yield~~ and ultimate tensile strength properties for the material are ~~requirements required~~ for the evaluation of fracture toughness test results.

6.2.2 *Postirradiation Preparation of Specimens:*

6.2.2.1 If end-tab welding (compound specimens) is to be performed (see Fig. 2), it must be verified that the temperature in the test region does not reach or exceed the irradiation temperature. Additionally, the procedure should minimize residual stresses that will affect the experimental results. To minimize the temperature in the notch region during welding, electron beam welding (two passes per weld, one on each side of the specimen) and the use of copper chill blocks are recommended. The irradiated material shall be of sufficient size to fully contain the plastic zone developed at maximum ~~load force~~. For information about determining the dimensions of irradiated material see Refs (6) and (7). A compound specimen fabrication procedure should not be used unless previously proven to have no significant influence on the fracture toughness test result.

6.2.2.2 If additional fatigue crack extension is performed after irradiation, the conditions outlined in 6.1.3 should be satisfied.

6.2.2.3 Side grooving of specimens, if required, may be performed after irradiation but should be performed following final fatigue crack extension.

6.2.3 *Postirradiation Specimen Testing*—If the recommendations of 6.2 on the sufficiency of test specimens cannot be satisfied, a decision on testing priorities will have to be made taking into consideration the results of the surveillance program described in Practice E 185 and other available information.

6.2.3.1 *Test Temperature Selection*—If fracture toughness properties in the transition region are of greatest need for measurements and correlations with the radiation-induced Charpy V-notch 41- J temperature shift, tests should be selected to define the reference temperature T_o , at which the median of the fracture toughness (K_{Jc}) distribution from IT size specimens will equal $100 \text{ MPa } \sqrt{m}$ ($91 \text{ ksi } \sqrt{\text{in.}}$). If fracture toughness in the fully plastic behavior region is of greatest need, J -integral tests should be performed at temperatures effecting fully plastic fracture behavior in the specimen.

6.2.3.2 *Loading Rates*—Test Method E 399 for plane strain fracture toughness testing defines a static test in the linear elastic regime as one carried out at a stress intensity rate, K , between 0.55 and $2.75 \text{ MPa } \sqrt{m}/s$ (0.5 and $2.5 \text{ ksi } \sqrt{\text{in.}}/s$). Test Methods E 1820 and E 1921 specify that specimen loading to 40% of the estimated maximum force must be completed in 0.1 to 10.0 min in static tests in the elastic-plastic and fully plastic regimes. Beyond these maximum limits, the tests can be considered dynamic. — The limits that define a conventional (quasi-static) test are specified in Test Methods E 399, E 1820 and E 1921 in case of elastic, elastic-plastic or fully plastic behavior, respectively.

6.3 *Data Development and Computational Procedures:*

6.3.1 *Elastic Behavior*—Test Method E 399 data development methods, computational procedures, and test validity criteria are to be applied for fully elastic test behavior.

6.3.2 ~~Elastic-Plastic Behavior~~ *Ductile-to-Brittle Transition Behavior*—Test Method E 1921 data development methods, computational procedures, and test validity criteria are to be applied for ~~fully elastic~~ ductile-to-brittle transition test behavior.

6.3.3 *Plastic Behavior*—The J -integral method or the J - R curve technique, or both, shall be applied as appropriate for the computation of fracture toughness when the material demonstrates fully plastic fracture behavior (Test Methods E 1820).

6.4 *Report:*

6.4.1 *Data*—In addition to the reporting requirements of 5.5 and Test Methods E 399, E 1820, and E 1921, the following shall be reported: force-deflection curve, specimen type and dimensions, method and location of displacement measurements, test temperature, specimen identification and orientation, measured fatigue precrack ~~crack length, size~~, amount of stable ductile tearing, and specimen loading rate (or stress-intensity rate). The validity criteria, the calculated fracture toughness, and the analytical method used also shall be reported. Specimen precracking records, original force-time curves, temperature records, analytical calculations, and photographs of the fracture surfaces of the broken specimens shall be kept on record by the test facility.

6.4.2 *Modified Specimen Reporting*—In addition to the reporting requirements of 6.4.1, when (reconstituted) specimens or other modified specimen types have been ~~made and~~ tested, the test specimen design shall be supplied.

7. ~~Precracked Charpy Impact Test~~

~~7.1 Presently, no test standard is available for the execution and analysis of precracked Charpy impact tests. Nevertheless, extensive literature is available on this topic Refs **Fracture Toughness Test at Impact Loading Rates**~~

~~7.1 Presently, no test standard is available for the execution and analysis of fracture toughness tests at impact loading rates on precracked Charpy specimens. Nevertheless, extensive literature is available on this topic Refs (3-9) ; what follows is intended to provide guidance to the user, based on the most widely used experimental and analysis procedures.~~

~~7.2 Specimen:~~

~~7.2.1 Design—The nominal dimensions and configuration of the specimen are given in Test Methods E 23 (Charpy Type A). The machined notch is extended (precracked) by fatigue cycling. Side grooving after precracking is optional.~~

~~7.2.2 Fatigue Precracking—The specimen shall be fatigue precracked to provide an a/W ratio between 0.45 and 0.55. Fatigue precracking will be in accordance with Test Methods E23 (Annex 4) ratio between 0.30 and 0.70. If the results in terms of J or δ are to be directly comparable to full-size standard fracture toughness values determined in accordance with Test Methods E 1820, Annexes A8-A12, a_c/W shall be in the range $0.45 < a_c/W < 0.70$. If the results in terms of K_{Ic} are to be directly comparable to full-size standard fracture toughness values determined in accordance with Test Method E 1921, a_c/W shall be in the range of $0.45 < a_c/W < 0.55$. Otherwise, shorter crack lengths ($0.30 < a_c/W < 0.45$) may be more advantageous. Fatigue precracking will be in accordance with Test Methods E 1820 or E 1921 in accordance with the parameter to be determined (that is, J/δ or K_{Ic}).~~

~~7.3 Special Requirements for Surveillance Applications—For a given neutron exposure level and material condition, a minimum of eight specimens is desirable to define the brittle/ductile transition.—For a given neutron exposure level and material condition, a minimum of eight specimens shall be tested in order to define the brittle/ductile transition. Ten specimens are recommended (two in addition to the eight tested) in the event retests are required.~~

~~7.3.1 Postirradiation Specimen Preparation, Fatigue Precracking—If fatigue precracking is performed after irradiation, the limits established in 7.2.2 shall not be exceeded.~~

~~7.3.2 Specimen Testing Equipment —The force measuring system (instrumented striker, amplifier, recording system) shall have a response of at least 100 kHz, which corresponds to a rise time (t_r) of no more than 3.5 μ s (ISO 14556). Furthermore, testing equipment the test should satisfy the following constraints:~~

~~Inertia Effects
Energy Criterion~~

~~$t \geq 3\tau$
 $W_0 \geq 3 W_m$~~

~~Damping Inertia Effects
Available Energy Criterion~~

~~$t^* \geq 3\tau$
 $W_0 \geq 3 W_m$~~

~~W_m~~

~~where:~~

~~$t-t^*$ = time to maximum or yield load, time to general yield force or specimen failure,~~

~~τ = period of the apparent specimen oscillation about the actual load force (τ is typically 40 μ s for a reactor vessel steel precracked Charpy specimen),~~

~~W_0 = total available energy of the pendulum during impact loading, and~~

~~W_m = energy corresponding to maximum force.~~

~~7.3.3 Postirradiation Specimen Testing :~~

~~7.3.3.1 Test Temperature Selection —Test temperatures should be chosen to enable assessment of the brittle/ductile transition region. The initial test temperature should coincide with the lower knee of the transition region determined from standard Charpy V-notch tests conducted in accordance with Practice E185E 2215.~~

~~7.3.3.2 Stress Intensity Rates During Loading—The initial loading rate should be 1.1×10^3 MPa \sqrt{m} /s (10³ ksi $\sqrt{in.}$ /s) or greater. A typical loading rate for impact testing of precracked Charpy specimens is 3.3×10^5 MPa \sqrt{m} /s. Upper and lower limits on loading rates are set by the inertial effects damping criterion ($t^* \geq 3 \tau$) and the energy criterion ($W_0 \geq 3 W_m$), respectively (3) .~~

~~7.3.3.3 Test Record— For each precracked Charpy test, a force vs. deflection or time record, or both, shall be generated. Fatigue crack length size shall be measured in accordance with Test Methods E23E 1820 (Annex 4).~~

~~7.3.3.4 Data Acquisition Equipment —Dynamic data acquisition is best accomplished using digital acquisition equipment. For these tests, data acquisition rates of the equipment should be capable of capturing at least one data point every two microseconds.~~

~~7.4 Data Development and Computation Procedures:~~

~~7.4.1 Elastic and Elastic-Plastic Behaviors—An ASTM standard method for determining dynamic fracture toughness for elastic and elastic-plastic fracture behavior (fracture occurs after general yielding) fracture behavior is not yet available for impact loading. A procedure used to approximate calculate the dynamic fracture toughness stress intensity factor from the energy absorbed up to maximum force specimen fracture is given in Appendix X1. Refs. **These values may be analyzed using the Master Curve approach of Test Method E 1921 in order to determine a dynamic value of the reference temperature. Refs (3-8) provide additional information on the data development methods, computational procedures, and test validity criteria.**~~