



Standard Test Method for Tumbler Test for Coke¹

This standard is issued under the fixed designation D 3402/D 3402M; the number immediately following the designation indicates the year of original adoption or, in the case of revision, the year of last revision. A number in parentheses indicates the year of last reapproval. A superscript epsilon (ϵ) indicates an editorial change since the last revision or reapproval.

1. Scope

1.1 This test method describes a procedure for obtaining a relative measure of the resistance to degradation of coke by impact and abrasion.

1.2 *Standard Procedure*—This procedure uses a coke sample sized to -75 mm (-3 in.) [-3 in.] and $+50$ mm ($+2$ in.) [$+2$ in.].

1.3 *Alternative Procedure*—This procedure using coke sized 50% of 63 by 50 mm ($2\frac{1}{2}$ by 2 in.) and 50% of 50 by 37.5 mm (2 by $1\frac{1}{2}$ in.).

1.4 The values stated in SI units shall be regarded as standard. Inch-pound units shall be accepted on an equivalent basis.—This procedure using coke sized 50 % of 63 by 50 mm [$2\frac{1}{2}$ by 2 in.] and 50 % of 50 by 37.5 mm [2 by $1\frac{1}{2}$ in.].

1.4 The values stated in either SI units or inch-pound units are to be regarded separately as standard. The values stated in each system may not be exact equivalents; therefore, each system shall be used independently of the other. Combining values from the two systems may result in non-conformance with the standard.

1.5 This standard does not purport to address all of the safety problems, if any, associated with its use. It is the responsibility of the user of this standard to establish appropriate safety and health practices and determine the applicability of regulatory limitations prior to use.

2. Referenced Documents

2.1 *ASTM Standards:*

D293 *Test Method for the Sieve Analysis of Coke*

D 294 *Tumbler Test for Coke—Method of Test for Tumbler Test for Coke*

D 346 *Practice for Collection and Preparation of Coke Samples for Laboratory Analysis²*

D4621 *Guide for Quality Management in an Organization that Samples or Tests Coal and Coke—Practice for Collection and Preparation of Coke Samples for Laboratory Analysis*

E 11 *Specification for Wire-Cloth Sieves for Testing Purposes*

E323 *Specification for Perforated-Plate Sieves for Testing Purposes²*—Specification for Wire Cloth and Sieves for Testing Purposes

3. Summary of Test Method

3.1 A sample of dry coke of designated size is tumbled in a rotating drum at a specified turning rate for a specified number of revolutions. Two indexes of its strength, the stability factor and the hardness factor, are determined by sieve analysis of the coke after treatment. Studies have indicated that there is no real difference in the stability factor as determined by the standard and alternative procedures. The alternative procedure produces hardness factor results averaging slightly higher than the standard procedure.

4. Significance and Use

4.1 Coke undergoes various degrees of degradation during removal from coke ovens, transportation, and its descent within a blast furnace to the combustion zone. These processes subject the coke to impact and abrasion. This test method is a relative measure of the resistance of coke to breakage when subjected to these degradation processes.

5. Apparatus

5.1 *Tumbler Machine* (see Fig. 1) —The tumbler machine consisting of a cylindrical steel drum 910 mm (36 in.) [36 in.] in inside

¹ This test method is under the jurisdiction of ASTM Committee D05 on Coal and Coke and is the direct responsibility of Subcommittee D05.15 on Plasticity and Swelling of Coal.

Current edition approved Jan. 15, 1993. Published March 1993. Originally published as D3402-75. Last previous edition D3402-81 on Metallurgical Properties of Coal and Coke.

Current edition approved Oct. 1, 2008. Published February 2009. Originally approved in 1975. Last previous edition approved in 2001 as D 3402 - 93(2001).

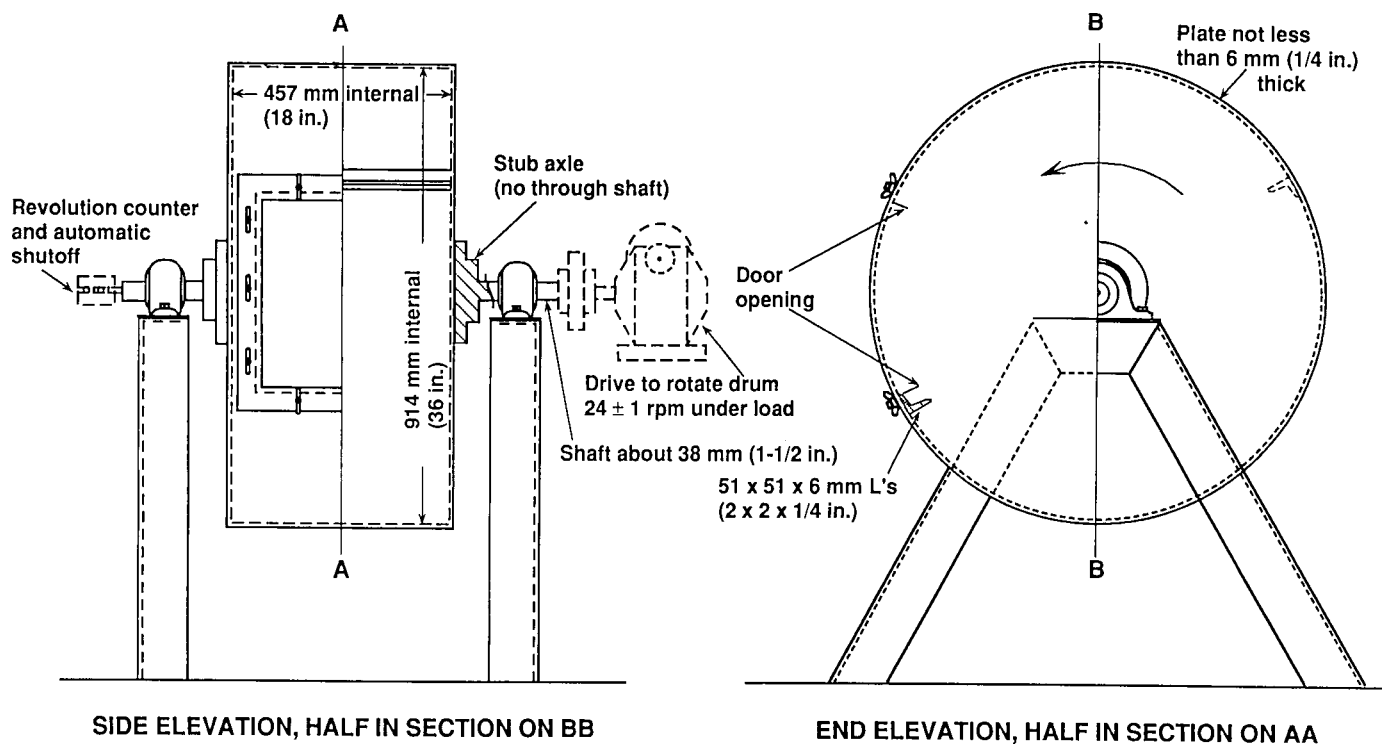

FIG. 1 Tumbler Test Apparatus

diameter and 455 mm (18 in.) in inside width and made of plate at least 6 mm (1/4 in.) thick. The machine may be constructed as a double drum mounted on a common shaft so that duplicate coke samples may be tested at the same time. Two equally spaced 50 by 50 by 6-mm (2 by 2 by 1/4-in.) steel angles extending across the width of each drum are solidly fastened inside each drum as shown. These angles are fastened to the shell so that the attached legs point away from the direction of rotation, thus giving a clear unobstructed shelf for lifting the coke. At least one door must be provided in each drum for charging and discharging the coke sample. This door preferably should extend nearly across the width of each drum. As an alternative, a door in the side of the drum is permissible. During the test the door must be fastened rigidly to the shell and must fit into the shell in order to have a smooth continuous inner surface. A dust-tight gasket must be provided to prevent loss of the abraded fines during the test. To provide for rotation, the drum is mounted on stub axles about 37.5 mm (1 1/2 in.) in diameter by means of flanges welded or bolted to the ends of the drum providing smooth inner surfaces. It is desirable that the apparatus be fitted with a revolution counter and preferably be equipped with an automatic device to stop the drum after the specified number of revolutions (1400). The tumbler drum must be replaced when the wear reduced the thickness to 3 mm (1/8 in.) in any area. The lift angles must be replaced when they wear to less than 48 mm (1 7/8 in.).

5.2 *Sieves*, for sieving the coke before and after the tumbler test. Square-mesh sieves having 75-mm (3-in.), 63-mm (2 1/2-in.), 50-mm (2-in.), 37.5-mm (1 1/2-in.), 25-mm (1-in.), and 63-mm (1/4-in.) actual openings between the wires to be used. The sieves shall conform to Specification E 11.

NOTE 1—User's attention is called to the fact that yields of certain sizes that determine the stability and hardness factors of 75 by 50-mm (3 by 2-in.) coke cannot be compared directly with results obtained by using sieves as specified prior to the 1950 revision of Method D 294 (predecessor of D3402). The stability factor (percent remaining on 25-mm (1-in.) sieve after tumbling) will be slightly higher than comparable previous results using the formerly specified 26.5-mm (1.06-in.) sieve.

5.3 *Weighing Scale*, capable of weighing 11 kg (25 lb), sensitive to 0.025 kg (0.05 lb).

6. Sampling

6.1 The gross sample of coke shall be collected in accordance with Specification D 346.

6.2 For the standard procedure, the quantity must be sufficient to obtain approximately 34 kg (75 lb) of coke passing a 75-mm (3-in.) and retained on a 50-mm (2-in.) square-mesh sieve.

6.3 For the alternative procedure sample, the quantity must be sufficient to obtain approximately 17 kg (38 lb) of coke passing a 63-mm (2 1/2-in.) and retained on a 25-mm (1-in.) square-mesh sieve and 17 kg (38 lb) of coke passing a 50-mm (2-in.) and retained on a 37.5-mm (1 1/2-in.) square-mesh sieve.

7. Preparation of Sample

7.1 Size the standard procedure sample on 75-mm (3-in.) and 50-mm (2-in.) square-mesh sieves, without crushing the larger pieces, in order to obtain a sample that will pass the 75-mm sieve and be retained on the 50-mm sieve. In sizing the