

International Standard



2020

INTERNATIONAL ORGANIZATION FOR STANDARDIZATION • МЕЖДУНАРОДНАЯ ОРГАНИЗАЦИЯ ПО СТАНДАРТИЗАЦИИ • ORGANISATION INTERNATIONALE DE NORMALISATION

Aerospace — Mechanical system parts — Preformed flexible steel wire rope for aircraft controls — Technical specification

Aéronautique et espace — Éléments de systèmes mécaniques — Câbles en acier souples préformés pour commandes d'aéronefs — Spécifications techniques

ITeH STANDARD PREVIEW

Second edition — 1984-11-01

(standards.iteh.ai)

ISO 2020:1984

<https://standards.iteh.ai/catalog/standards/sist/678e9cef-559f-4878-83af-c34aefb2f49/iso-2020-1984>

UDC 629.7.062 : 427

Ref. No. ISO 2020-1984 (E)

Descriptors : aircraft industry, aircraft equipment, control devices, cable controls, wire rope, specifications, dimensions, tests, performance tests, test equipment, packing, marking, designation.

Price based on 8 pages

Foreword

ISO (the International Organization for Standardization) is a worldwide federation of national standards bodies (ISO member bodies). The work of preparing International Standards is normally carried out through ISO technical committees. Each member body interested in a subject for which a technical committee has been established has the right to be represented on that committee. International organizations, governmental and non-governmental, in liaison with ISO, also take part in the work.

Draft International Standards adopted by the technical committees are circulated to the member bodies for approval before their acceptance as International Standards by the ISO Council. They are approved in accordance with ISO procedures requiring at least 75 % approval by the member bodies voting.

International Standard ISO 2020 was prepared by Technical Committee ISO/TC 20, *Aircraft and space vehicles*.

ISO 2020 was first published in 1973. This second edition cancels and replaces the first edition, of which it constitutes a technical revision.

iTeh STANDARD PREVIEW
(standards.iteh.ai)
ISO 2020:1984
<https://standards.iteh.ai/catalog/standards/sist/678e9cef-559f-4878-83af-cf34aefb2f49/iso-2020-1984>

Aerospace — Mechanical system parts — Preformed flexible steel wire rope for aircraft controls — Technical specification

1 Scope and field of application

This International Standard defines the technical requirements which shall be satisfied by flexible wire ropes of the “preformed” type, made either of carbon steel wire or of corrosion-resisting steel wire, for aircraft controls. The wire rope shall be capable of operation within a temperature range of -54 to $+121$ °C.

2 References

ISO 2408, *Steel wire ropes for general purposes — Characteristics*.

ISO 2532, *Steel wire ropes — Vocabulary*.

ISO 3108, *Steel wire ropes for general purposes — Determination of actual breaking load*.

3 Definitions

The definitions given in this clause only apply to this International Standard but, where appropriate, are in accordance with ISO 2532.

3.1 wire : Each cylindrical steel element.

3.2 strand : An element of rope consisting of an assembly of several wires of appropriate shape and dimensions laid helically in one or more layers over a straight centre wire.

3.3 wire rope : A construction of several strands wound helically in one or more layers over a straight centre strand.

3.4 preformed wire rope : A wire rope in which the wires in the strand and the strands in the rope are formed during rope manufacture into the shape that they will assume in the finished rope.

3.5 diameter :

3.5.1 nominal diameter : The value by which the diameter of the wire, strand or rope is designated.

3.5.2 measured (or actual) diameter : That diameter which is obtained by measuring in accordance with a specified method (see 7.2.2).

3.6 length of lay (or pitch) : The distance parallel to the axis of the strand or rope, in which a wire or strand makes one complete turn about the axis, is designated as the length of lay (or pitch) of the strand or wire rope.

3.7 core wire (king wire) : The centre wire of each strand.

3.8 centre or core strand (of a wire rope) : A straight strand composed of wire as for the other strands.

3.9 elongation : For the purpose of this International Standard only, that length by which the rope extends between defined upper and lower limits of load (i.e., between first and second reading), expressed as a percentage of the gauge length measured at the lower limit (see 7.4).

3.10 lot : A lot shall consist of not more than 6 000 m of wire rope of the same construction and diameter produced continuously by one machine or by one series of progressive processing machines.

4 Carbon steel wire for ropes

4.1 Wire manufacture

4.1.1 Steel

The steel shall be manufactured by any process other than the bottom blown converter process and the cast analysis shall be within the limits given in table 1.

Table 1 — Limits for the cast analysis

Element(s)	% (m/m)	
	min.	max.
Carbon	0,5	0,85
Silicon	—	0,35
Manganese	0,4	0,9
Phosphorus	—	0,04
Sulfur	—	0,04
Sulfur + phosphorus combined	—	0,065

4.1.2 Wire

The wire shall be cold drawn from rods free from harmful defects and shall be zinc coated at a suitable stage of manufac-

ture to meet the specified properties and performance of the finished rope. The wire shall also satisfy the additional requirements given in 4.2.

4.2 Additional requirements

4.2.1 Wire diameter tolerance

Table 2 — Wire diameter tolerance
Dimensions in millimetres

Nominal diameter		Tolerance ±
from	to less than	
0,15	0,40	0,010
0,40	1,00	0,015

4.2.2 Tensile strength

The wire tensile strength shall be specified by the ropemaker.

4.2.3 Zinc coating

The minimum amount of zinc coating on the finished wire shall correspond to the values in table 3.

Table 3 — Minimum amounts of zinc coating
Dimensions in millimetres

Wire diameter		Zinc coating min. g/m ²
from	to less than	
0,15	0,25	10
0,25	0,40	15
0,40	0,50	30
0,50	0,80	50

5 Corrosion-resisting steel wire for ropes

5.1 Wire manufacture

5.1.1 Steel

The steel shall be manufactured by an electric furnace process or any other process that will produce steel capable of meeting this specification. The cast analysis shall be within the limits given in table 4.

Table 4 — Limits for cast analysis

Element	% (m/m)	
	min.	max.
Carbon	—	0,15
Silicon	—	1,0
Manganese	—	2,0
Phosphorus	—	0,045
Sulfur	—	0,03
Chromium	17,0	20,0
Nickel	8,0	12,0

5.1.2 Wire

The wire shall be cold drawn from rods free from harmful defects and supplied in the cold drawn condition to meet the

specified properties and performance of the finished rope. The wire shall also satisfy the additional requirements given in 5.2.

5.2 Additional requirements

5.2.1 Wire diameter tolerance

Table 5 — Wire diameter tolerance
Dimensions in millimetres

Nominal diameter		Tolerance ±
from	to less than	
0,20	0,40	0,010
0,40	1,00	0,015

5.2.2 Tensile strength

The wire tensile strength shall be specified by the ropemaker.

6 Manufacture of wire rope

6.1 Types of construction

Wire ropes covered by this specification may be of two types (see table 6).

6.1.1 7 × 7 construction

This shall be composed of six outer strands each of seven wires laid in a right-hand direction around a centre strand of seven wires, with a length of lay of between six and eight times the nominal diameter of the rope.

The centre strand shall be composed of a layer of six wires laid in a right-hand direction around a core or king wire. It shall be of sufficient diameter to give full support to the outer strands, and shall have a length of lay not exceeding 60 % of the length of lay of the complete rope.

The six outer strands shall be composed of a layer of six wires laid in a left-hand direction around a core or king wire; they shall have a length of lay not exceeding 60 % of the length of lay of the complete rope.

6.1.2 7 × 19 construction

This shall be composed of six outer strands of 19 wires laid in a right-hand direction around a centre strand of 19 wires.

The centre strand shall be composed of a first layer of six wires laid in a right-hand direction around a core or king wire, and a second layer of 12 wires laid in a right-hand direction. It shall be of sufficient diameter to give full support to the outer strands.

The six outer strands shall be composed of a first layer of 6 wires and a second layer of 12 wires laid in a left-hand direction around a core or king wire.

The length of lay of the centre strand and of the outer strands shall be as follows :

- a) the inner layer of six wires shall have a length of lay of less than 60 % of the length of lay of the outer layer;
- b) the outer layer of 12 wires shall have a length of lay of less than 50 % of the length of lay of the rope;
- c) the six outer strands shall be closed around the centre strand with a length of lay between six and eight times the nominal diameter of the rope.

6.2 Joints

Tucked joints may be made in wires of diameter equal to or less than 0,20 mm. For wires of diameter greater than 0,20 mm the joints shall be made by electric welding or brazing. In the same strand, joints shall be not less than 6 m apart.

6.3 Lubrication

A satisfactory aircraft control wire lubricant will reduce the internal friction and prevent corrosion. Therefore a suitable type of friction-preventing compound having non-corrosive properties shall be applied so that each wire is coated. The lubricant shall have good lubrication properties at $-54\text{ }^{\circ}\text{C}$ as well as at $+121\text{ }^{\circ}\text{C}$. To ensure a satisfactory service life, the lubricant shall be resistant to oxidation and shall not induce corrosion.

6.4 Rope lengths

Ropes shall be delivered in minimum lengths of 300 m, except that up to 20 % of the rope ordered may be supplied in lengths between 150 and 300 m.

7 Inspection of wire rope

7.1 General procedure requirements

Before every inspection the inspector shall be satisfied that the measuring instruments are correctly calibrated. Inspections and tests referred to in this clause shall be carried out on each lot produced.

7.2 Inspection of production lengths

7.2.1 Visual examination

All details of workmanship and finish shall be in accordance with the best practice for high quality aircraft wire rope consistent with the requirements of this International Standard. The finished cable shall be uniform in construction and securely laid, free from kinks, loose wires, loose strands, or other defects. All wire rope shall be examined for workmanship and finish to determine compliance. For this purpose, the wire rope shall travel no faster than 30 m/min and shall be stopped for closer inspection when necessary. This inspection shall take place at the time the wire rope is wound on shipping reels. Any discard from the head or starting end of the manufacturing reel shall be removed prior to winding of the shipping reels.

7.2.2 Measurement of diameter

The actual diameter of the rope shall be measured after production with a measuring device with jaws broad enough to cover not less than two adjacent strands. At each of three points spaced at least 10 m apart, two measurements shall be taken at right angles to each other. The average of these six measurements shall fall within the maximum and minimum diameters indicated in table 6, columns 3 and 4. Each end of each manufactured length of wire rope shall be measured in this manner. These measurements shall be made on a straight portion of the rope under no tension.

7.2.3 Preforming test

The increase in the diameter of the wire rope after cutting shall not exceed the value indicated in table 6. The measurement shall be made as near as possible to the end of the rope on both pieces. (This test may be carried out at the time of sampling for the various mechanical tests.)

To avoid distorting the cable ends, it is recommended that cutting be carried out electrically or using cutters with constricting jaws.

7.3 Breaking strength of rope

The actual breaking strength of wire rope shall be determined in accordance with ISO 3108 with the exception that reference to ISO 2408 in that International Standard shall be replaced with table 6 of this International Standard.

7.4 Elongation and proof testing

7.4.1 Elongation test

For each lot of wire rope a sufficient length shall be selected to provide an unobstructed test length of 250 mm minimum between the jaws of the test machine. On the test length prepared the minimum gauge length of 250 mm shall be accurately measured, marked and recorded under an initial load equal to 1 % of the minimum breaking load of the rope. The load shall then be progressively increased until a load equal to 60 % of the specified minimum breaking load is reached, and this shall be maintained for a period of 1 min. The length between the gauge points shall again be measured. The difference between the two measurements is the elongation and shall be expressed as a percentage of the original length. Results of the elongation test shall indicate a change in length not exceeding 1,5 %.

NOTE — The manufacturer may use, at his discretion, other devices which have been developed to measure elongation. However the values of 1 % and 60 % of the specified minimum breaking load shall be retained.

7.4.2 Proof test

Using the same test length as for the preceding elongation test, the load shall be progressively increased until a value of 80 % of the specified minimum breaking load is reached and maintained for a minimum period of 5 s. This load shall then be released and the test length completely separated into its constituent wires and each wire shall be examined. The test length has passed the test if no single wire is broken.

NOTE — The manufacturer may use, at his discretion, electronic devices which have been developed to detect the breaking of wires while the above test is being carried out. However in the event of any conflict of evidence, the test method described above shall be used as the reference method.

7.5 Endurance test

An endurance test shall be carried out for each lot of wire rope. The number of reversals and the wire rope test load shall be as indicated in table 7. The test machinery shall conform to figure 1. The total travel of the cable in one direction shall be 343 mm. The test pulleys shall be made of steel and shall conform to the dimensions of figure 2 and table 8. The application of lubricant to the endurance test sample, in addition to the lubricant applied during the manufacture of wire rope, shall not be permitted either before or during the endurance test. After endurance testing the breaking strength of the wire rope shall be rechecked in accordance with 7.3 except for the following :

- a) the test specimen shall be that portion of the wire rope that passes over the test pulley during the endurance test;
- b) the breaking strength shall be equal to or greater than the values specified in table 7.

8 Re-test

If the requirements of clause 7 are not met, a re-test may be carried out taking two further test lengths from the end of the same production length. If both test lengths conform to the requirements of this International Standard, the relevant lot of wire rope shall be deemed to comply with requirements of this International Standard. A complete report of the tests shall be prepared and supplied with the dispatch documents for each test lot.

9 Qualification approval and certificate of conformity

9.1 Quality assurance approval

The quality assurance requirements shall be in accordance with the quality control and approval procedures in force in the country of the purchaser. The approval shall be carried out by the airworthiness authorities or their delegated representative who may be the prime contractor.

9.2 Product qualification testing approval

As each lot of wire rope produced in accordance with this International Standard shall pass all of the tests laid down in this International Standard, product qualification testing approval is not required.

9.3 Certificate of conformity

Each lot of wire rope supplied in conformity with this International Standard shall be accompanied by a certificate of conformity.

10 Designation

Each lot of wire rope ordered to the specifications given in this International Standard shall be designated in accordance with the following example :

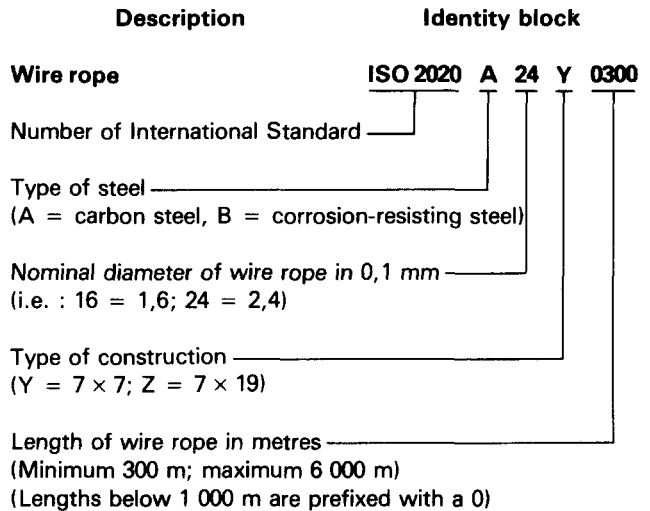

For call up purposes on drawings it is not normal to call up wire rope on its own as assemblies of wire rope and end fittings are usually shown. In this instance the designation in the list of parts need not show the length code.

11 Packing and marking

11.1 Packing

11.1.1 Ordinary packing

The rope shall be wound on a reel designed for the purpose. The diameter of the barrel of the reel shall exceed 40 times the diameter of the rope. The flanges and the barrel of the reel shall be covered with waterproof material before the rope is wound onto the reel. When it is fully wound, the exposed surface shall be covered with a layer of inert waterproof material held down by appropriate means.

11.1.2 Special packing

Any special packing shall be specified in the order.

11.2 Marking

A label shall be fixed on the reel bearing the following information :

- a) the designation shown in clause 10;
- b) the name of the manufacturer;
- c) the number of order;
- d) test report number(s) (lot numbers);
- e) inspection stamps.

Table 6 – Principal properties of wire rope

1 Nominal diameter of wire rope mm	2 Construction	3 Measured diameter		5 Minimum breaking strength		7 Increase in diameter after preforming test max. mm	8 Approximate mass per 100 m kg
		min. mm	max. mm	Carbon steel kN	Corrosion-resisting steel kN		
1,6	7 × 7	1,6	1,8	2,15	2,15	0,23	1,2
2,4		2,4	2,7	4,10	4,10	0,25	2,4
3,2	7 × 19	3,2	3,5	4,45	4,45	0,28	2,6
4,0		4,0	4,4	8,90	7,85	0,43	4,3
4,8		4,8	5,2	12,45	10,70	0,48	6,7
5,6		5,6	6,0	18,60	16,50	0,51	9,7
6,4		6,4	6,8	24,90	22,25	0,53	12,8
8,0		8,0	8,6	31,20	28,50	0,61	16,4
9,5		9,5	10,2	43,60	40,05	0,69	25,8
				64,10	53,40		36,2

Table 7 – Breaking strength after endurance test

Nominal diameter of wire rope mm	Construction	Wire rope test load ¹⁾ min. kN	Number of reversals ²⁾	Minimum breaking strength	
				Carbon steel ³⁾ kN	Corrosion-resisting steel ⁴⁾ kN
1,6	7 × 7	22	70 000	1,07	1,28
2,4		40		2,05	2,45
3,2	7 × 19	80	130 000	2,25	4,7
4,0		107		4,45	4,7
4,8		165		6,25	6,4
5,6		225		9,30	9,9
6,4		285		12,45	13,4
8,0		400		15,60	17,0
9,5		535		21,80	24,0
				32,05	32,0

- 1) The wire rope test load is equal to one half the weight which includes idler pulley and hanger.
- 2) 1 cycle = 2 reversals.
- 3) Minimum breaking strength equal to 50 % of the original minimum breaking strength, prior to the endurance test.
- 4) Minimum breaking strength equal to 60 % of the original minimum breaking strength, prior to the endurance test.

Table 8 – Dimensions of steel pulley used in endurance test

Nominal diameter of wire rope d	Construction	Pulley ratio ¹⁾ to 1	C 2)3)	D + 0,13 0	E_r + 0,05 0	G 2)
mm			mm	mm	mm	mm
1,6	7 × 7	12,0	24	19,05	0,914	10
2,4			36	28,58	1,32	
3,2	7 × 19	7,0	24	16,67	1,75	
4,0			32	22,22	2,20	
4,8		9,5	50	37,69	2,60	
5,6			60	45,24	3,00	
6,4			70	52,78	3,40	
8,0			80	60,32	4,24	
9,5			100	75,40	5,08	
			120	90,49		14

1) Ratio between pulley diameter D and diameter of wire rope d .

2) Reference numbers, not a mandatory dimension. Left to manufacturer's discretion.

3) $C \approx D + 3d$.

iTeh STANDARD PREVIEW
(standards.iteh.ai)

ISO 2020:1984

<https://standards.iteh.ai/catalog/standards/sist/678e9cef-559f-4878-83af-c34aefb2f49/iso-2020-1984>

Dimensions in millimetres

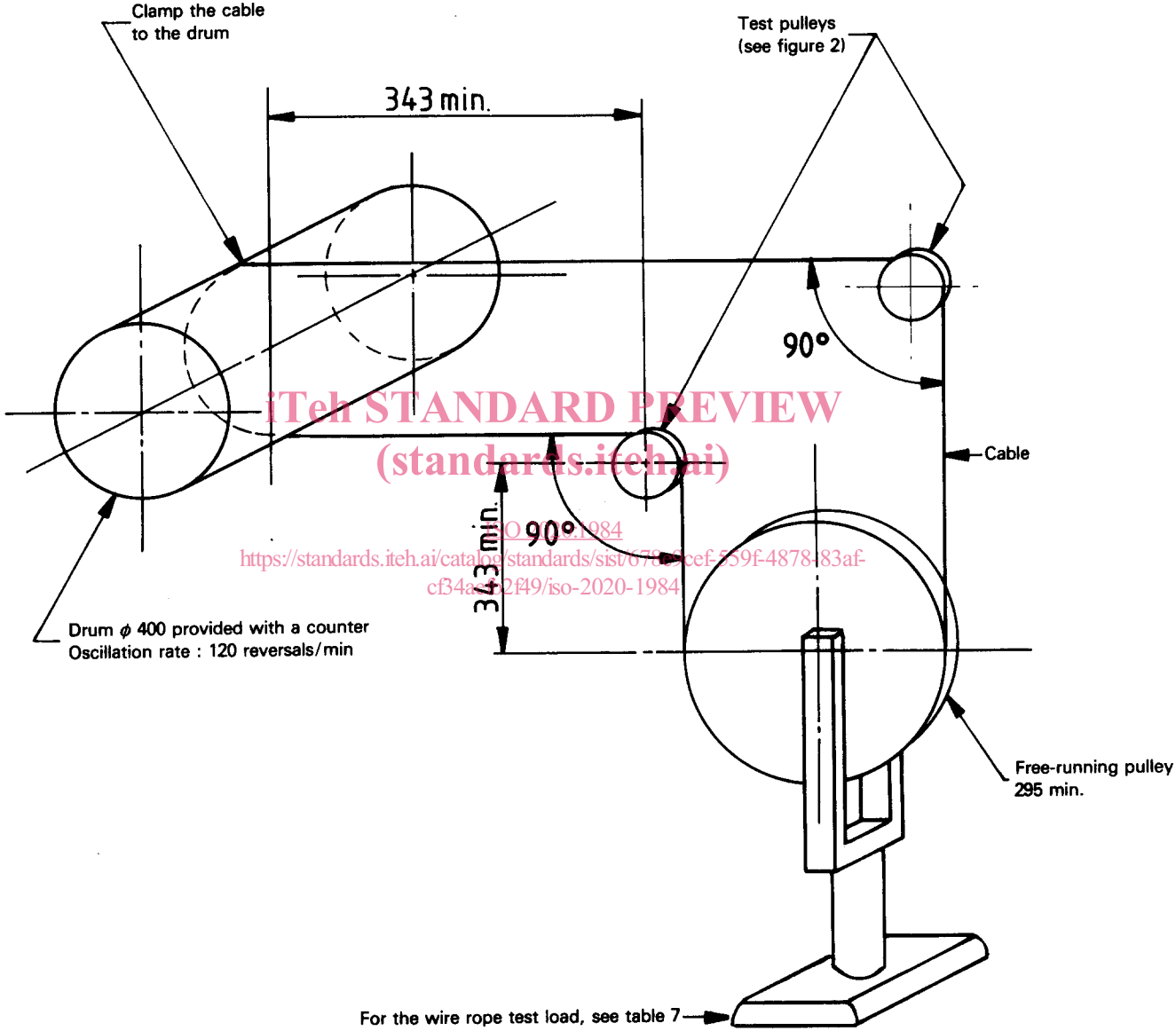

Figure 1 — Schematic diagram for endurance test — Equipment and test conditions