



Designation: E2618 – 09

Standard Test Method for Measurement of Particulate Emissions and Heating Efficiency of Outdoor Solid Fuel-Fired Hydronic Heating Appliances¹

This standard is issued under the fixed designation E2618; the number immediately following the designation indicates the year of original adoption or, in the case of revision, the year of last revision. A number in parentheses indicates the year of last reapproval. A superscript epsilon (ϵ) indicates an editorial change since the last revision or reapproval.

1. Scope

1.1 This test method applies to wood-fired or automatically fed biomass burning hydronic heating appliances, which the manufacturer specifies for outdoor installation or in structures not normally occupied by humans. These appliances transfer heat to the indoor environment through circulation of a liquid heat exchange media such as water or a water-antifreeze mixture.

1.2 The test method simulates hand loading of seasoned cordwood or fueling with a specified biomass fuel and measures particulate emissions and delivered heating efficiency at specified heat output rates based on the appliance's rated heating capacity.

1.3 Particulate emissions are measured by the dilution tunnel method as specified in Test Method E2515. Delivered efficiency is measured by determining the heat output through measurement of the flow rate and temperature change of water circulated through a heat exchanger external to the appliance and determining the input from the mass of dry fuel and its higher heating value. Delivered efficiency does not attempt to account for pipeline loss.

1.4 Products covered by this test method include both pressurized and non-pressurized heating appliances intended to be fired with wood or automatically fed biomass fuels. These products are hydronic heating appliances which the manufacturer specifies for outdoor installation or in structures not normally occupied by humans. They are often connected to an indoor heat exchanger by insulated pipes buried in the ground and normally include a pump to circulate heated liquid. They are used to heat structures such as homes, barns, and greenhouses and can heat domestic hot water, spas, or swimming pools.

1.5 Distinguishing features of products covered by this standard include:

1.5.1 Manufacturers specify outdoor installation or installation in structures not normally occupied by humans.

1.5.2 A firebox with an access door for hand loading of fuel or a hopper and automated feed system for delivery of particulate fuel such as wood pellets or solid biomass fuel to a burn pot or combustion chamber.

1.5.3 Typically a thermostatic control device that controls combustion air supply or fuel delivery, or both, to maintain the liquid in the appliance within a predetermined temperature range provided sufficient fuel is available in the firebox or hopper.

1.5.4 A chimney or vent that exhausts combustion products from the appliance.

1.6 The values stated are to be regarded as the standard whether in inch-pound or SI units. The values given in parentheses are for information only.

1.7 *This standard does not purport to address all of the safety concerns, if any, associated with its use. It is the responsibility of the user of this standard to establish appropriate safety and health practices and determine the applicability of regulatory limitations prior to use.*

2. Referenced Documents

2.1 *ASTM Standards*:²

[D4442 Test Methods for Direct Moisture Content Measurement of Wood and Wood-Base Materials](#)

[E631 Terminology of Building Constructions](#)

[E711 Test Method for Gross Calorific Value of Refuse-Derived Fuel by the Bomb Calorimeter \(Withdrawn 2011\)](#)³

[E2515 Test Method for Determination of Particulate Matter Emissions Collected by a Dilution Tunnel](#)

¹ This test method is under the jurisdiction of ASTM Committee E06 on Performance of Buildings and is the direct responsibility of Subcommittee E06.54 on Solid Fuel Burning Appliances.

Current edition approved Feb. 15, 2009. Published April 2009. Originally approved in 2008. Last previous edition approved in 2008 as E2618 – 08. DOI: 10.1520/E2618-09.

² For referenced ASTM standards, visit the ASTM website, www.astm.org, or contact ASTM Customer Service at service@astm.org. For *Annual Book of ASTM Standards* volume information, refer to the standard's Document Summary page on the ASTM website.

³ The last approved version of this historical standard is referenced on www.astm.org.

3. Terminology

3.1 *Definitions*—Definitions are in accordance with Terminology E631, unless otherwise indicated.

3.2 *Definitions of Terms Specific to This Standard:*

3.2.1 *burn rate*—the rate at which test fuel is consumed in an appliance measured in kilograms or pounds of fuel (dry basis) per hour.

3.2.2 *delivered efficiency*—the percentage of heat available in a test fuel charge that is delivered to a simulated heating load as specified in this test method. This test does not account for jacket losses or for transfer line losses which will vary with actual application.

3.2.3 *firebox*—the chamber in the appliance in which the test fuel charge is placed and combusted.

3.2.4 *hydronic heating*—a heating system in which a heat source supplies energy to a liquid heat exchange media such as water that is circulated to a heating load and returned to the heat source through pipes.

3.2.5 *manufacturer's rated heat output capacity*—the value in Btu/h (MJ/h) that the manufacturer specifies a particular model of hydronic heating appliance is capable of supplying at its design capacity as verified by testing, in accordance with Section 12.

3.2.6 *test fuel charge*—a full load of fuel as specified in Section 12 placed in the appliance at the start of the emission test run or the mass of fuel consumed by automatically fed appliance during a test run.

3.2.7 *test run*—an individual emission test which encompasses the time required to consume the mass of the test fuel charge.

3.2.8 *thermostatic control*—a control device that opens, closes or modulates a circuit to control the rate of fuel consumption in response to the temperature of the heating media in the heating appliance.

4. Summary of Test Method

4.1 *Dilution Tunnel*—Emissions are determined using the “dilution tunnel” method specified in Test Method E2515. The flow rate in the dilution tunnel is maintained at a constant level throughout the test cycle and accurately measured. Samples of the dilution tunnel flow stream are extracted at a constant flow rate and drawn through high efficiency filters. The filters are dried and weighed before and after the test to determine the particulate emissions catch and this value is multiplied by the ratio of tunnel flow to filter flow to determine the total emissions produced in the test cycle.

4.2 *Delivered Efficiency*—The efficiency test procedure takes advantage of the fact that this type of appliance delivers heat through circulation of the heated liquid (water) from the appliance to a remote heat exchanger and back to the appliance. Measurements of the water temperature difference as it enters and exits the heat exchanger along with the measured flow rate allow for an accurate determination of the useful heat output of the appliance. The input is determined by weight of the test fuel charge, adjusted for moisture content, multiplied by the higher heating value. Additional measurements of the

appliance weight and temperature at the beginning and end of a test cycle are used to correct for heat stored in the appliance.

4.3 *Operation*—Appliance operation is conducted on a hot-to-hot test cycle meaning that the appliance is brought to operating temperature and a coal bed is established prior to the addition of the test fuel charge and measurements are made for each test fuel charge cycle. The measurements are made under constant heat draw conditions within predetermined ranges. No attempt is made to modulate the heat demand to simulate an indoor thermostat cycling on and off in response to changes in the indoor environment. Four test categories are used. These are:

4.3.1 *Category I*—A heat output of 15 % or less of Manufacturer's Rated Heat Output Capacity.

4.3.2 *Category II*—A heat output of 16 to 24 % of Manufacturer's Rated Heat Output Capacity.

4.3.3 *Category III*—A heat output of 25 to 50 % of Manufacturer's Rated Heat Output Capacity.

4.3.4 *Category IV*—Manufacturer's Rated Heat Output Capacity.

5. Significance and Use

5.1 The measurement of particulate matter emission rates is an important test method widely used in the practice of air pollution control.

5.1.1 These measurements, when approved by federal or state agencies, are often required for the purpose of determining compliance with regulations and statutes.

5.1.2 The measurements made before and after design modifications are necessary to demonstrate the effectiveness of design changes in reducing emissions and make this standard an important tool in manufacturer's research and development programs.

5.2 Measurement of heating efficiency provides a uniform basis for comparison of product performance that is useful to the consumer. It is also required to relate emissions produced to the useful heat production.

5.3 This is a laboratory method and is not intended to be fully representative of all actual field use. It is recognized that users of hand-fired wood burning equipment have a great deal of influence over the performance of any wood-burning appliance. Some compromises in realism have been made in the interest of providing a reliable and repeatable test method.

6. Apparatus

6.1 *Scale*—A platform scale capable of weighing the appliance under test and associated parts and accessories when completely filled with water to an accuracy of ± 1.0 lb (± 0.5 kg).

6.2 *Heat Exchanger*—A water-to-water heat exchanger capable of dissipating the expected heat output from the system under test.

6.3 *Temperature Difference Measurement*—Thermocouples or a thermopile installed in thermowells shall be used to measure the temperature difference in water entering and leaving the heat exchanger. The temperature difference measurement shall have an uncertainty of $\pm 0.50^\circ\text{F}$ ($\pm 0.25^\circ\text{C}$).

6.4 *Water Flow Meter*—A totalizing type water flow meter with a resolution of 0.1 gal (0.025 L) and an accuracy of 0.5 % of volume recorded or a flow meter with an accuracy of ± 0.01 gal/min (± 0.0025 L/min).

6.5 *Recirculation Pump*—Circulating pump used during test to prevent stratification of liquid being heated.

7. Hazards

7.1 These tests involve combustion of solid fuel and substantial release of heat and products of combustion. The heating system also produces large quantities of very hot water and the potential for steam production and system pressurization. Pressurized (closed system) appliances must include an appropriately rated American Society of Mechanical Engineers (ASME) pressure relief device and a pressure vessel that complies with the ASME Pressure Vessel Code. Appropriate precautions must be taken to protect personnel from burn hazards and respiration of products of combustion.

8. Sampling, Test Specimens, and Test Appliances

8.1 Test specimens shall be supplied as complete appliances including all controls and accessories necessary for installation in the test facility. A full set of specifications and design and assembly drawings shall be provided when the product is to be placed under certification of a third-party agency. The manufacturer’s written installation and operating instructions are to be used as a guide in the set up and testing of the appliance.

9. Preparation of Apparatus

9.1 The appliance is to be placed on a scale capable of weighing the appliance fully loaded with a resolution of ± 1.0 lb (± 0.5 kg).

9.2 The appliance shall be fitted with the type of chimney recommended or provided by the manufacture and extending to 15 ± 0.5 ft (4.6 ± 0.15 m) from the upper surface of the scale. If no flue or chimney system is recommended or provided connect the appliance to a flue of a diameter equal to the flue

outlet of the appliance and extending 15 ± 0.5 ft (4.6 ± 0.15 m) from the top of the scale. For flue systems not provided by the manufacturer, the flue section from the appliance flue collar to 8 ± 0.5 ft (2.44 ± 0.15 m) above the scale shall be single wall stove pipe and the remainder of the flue shall be double wall insulated Class A chimney.

9.3 The manufacturer may request that a recirculation pump be installed between connections at the top and bottom of the appliance to minimize thermal stratification. The pump shall not be installed in such a way as to change or affect the flow rate between the appliance and the heat exchanger. As an alternative, the testing lab may employ a thermocouple tree to determine the average unit temperature.

9.4 Prior to filling the tank, weigh and record the appliance mass.

9.5 Plumb the unit to a water-to-water heat exchanger with sufficient capacity to draw off heat at the maximum rate anticipated. Route hoses and electrical cables and instrument wires in a manner that does not influence the weighing accuracy of the scale as indicated by placing dead weights on the platform and verifying the scale’s accuracy.

9.6 Locate thermocouples to measure the water temperature at the inlet and outlet of the heat exchanger in the supply line and return line from the cooling water system. Also install a calibrated water flow meter. If temperature differences are expected to be small, a differential thermopile should be used to measure the water delta-T. The water flow meter is to be installed on the cooling water inlet side of the heat exchanger so that it will operate at the same temperature as its calibration. Place the heat exchanger in a box with 2 in. (50 mm) of expanded polystyrene (EPS) foam insulation surrounding it to minimize heat losses form the heat exchanger. The reported efficiency and heat output rate shall be based on measurements made on the load side of the system. (See Fig. 1 and Fig. 2.)

9.7 Temperature instrumentation shall be installed in the output and return lines from the appliance (supply side). The

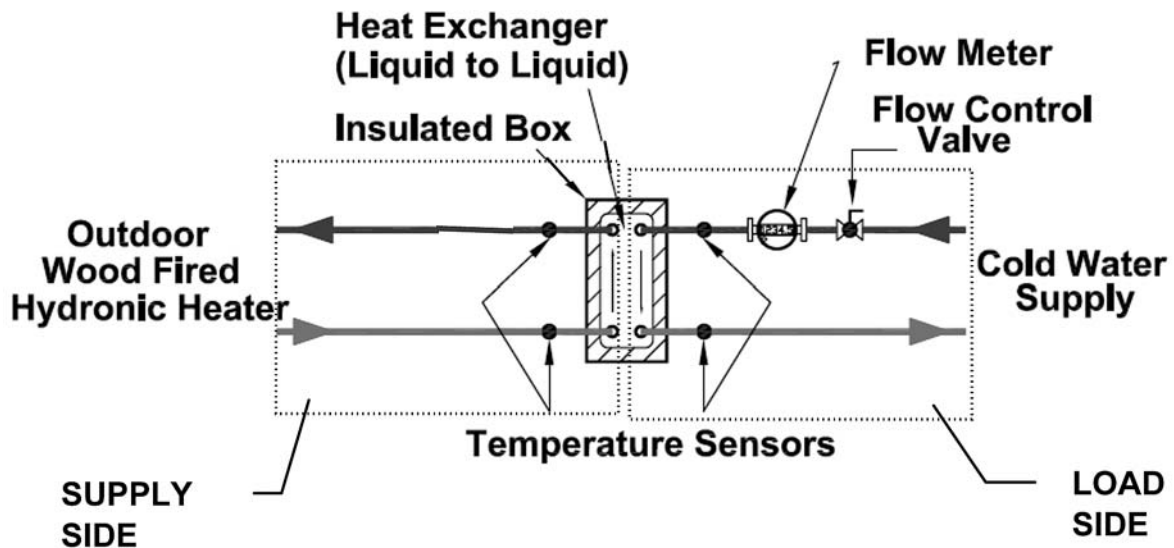

FIG. 1 Heat Exchanger Schematic

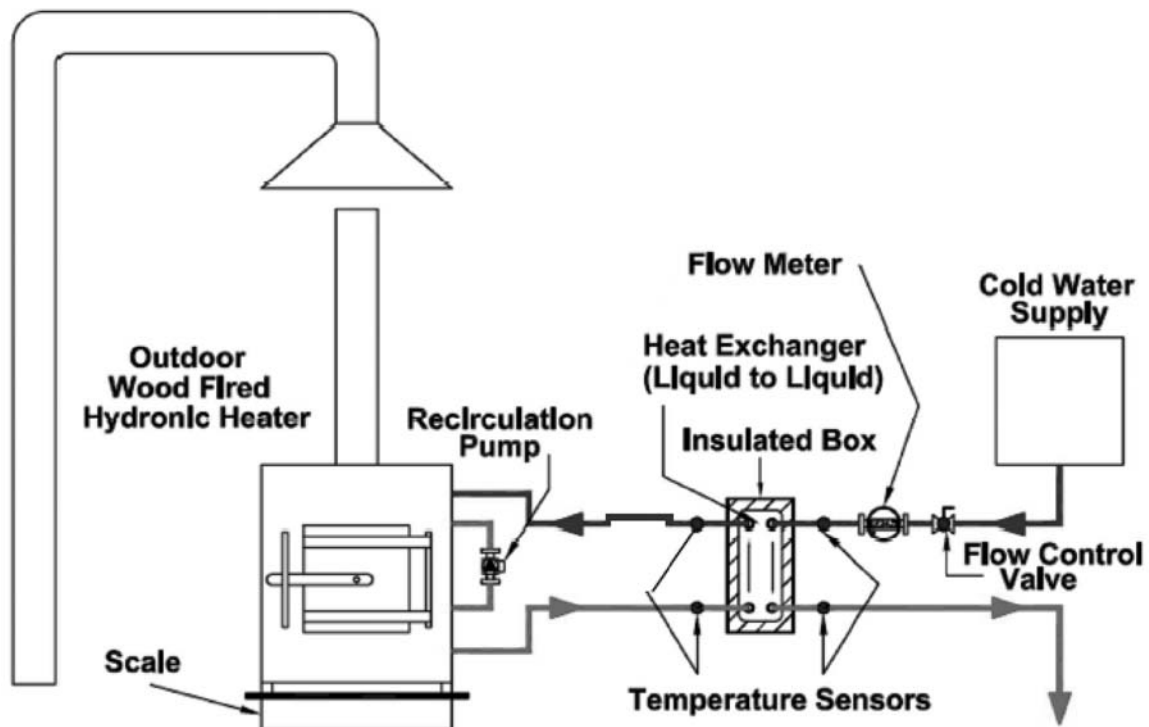

FIG. 2 Set-Up Schematic

average of the outlet and return water temperature on the supply side of the system shall be considered the average appliance temperature for calculation of heat storage in the appliance (TF_{avg} and TI_{avg}).

9.8 Fill the system with water. Determine the total weight of the water in the appliance when the water is circulating. Verify that the scale indicates a stable weight under operating conditions. Make sure air is purged properly.

10. Calibration and Standardization

10.1 *Temperature Sensors*—Temperature measuring equipment shall be calibrated to National Institute of Standards and Technology (NIST) traceable standards at least once every six months.

10.2 *Water Flow Meter*—The water flow meter shall be calibrated using NIST Traceable methods at least once every six months. At the conclusion of each test run that accuracy of the water meter shall be verified by collecting water from the outlet of the load side of the system for a timed interval and weighing the water collected. The flow rate in gallons per minute shall be within $\pm 0.5\%$ of that indicated by the water meter.

10.3 *Scales*—The scales used to weigh the appliance and test fuel charge shall be calibrated using NIST Traceable methods at least once every six months.

10.4 *Moisture Meter*—The moisture meter shall be calibrated per the manufacturer's instructions and checked before each use.

11. Conditioning

11.1 Prior to testing, the non-catalytic appliance is to be operated for a minimum of 10 h using a medium heat draw rate. Catalytic units shall be operated for a minimum of 50 h using a medium heat draw rate. The pre-burn for the first test can be included as part of the conditioning requirement. If conditioning is included in pre-burn, then the appliance shall be aged with fuel meeting the specifications outlined in 12.2 with a moisture content between 18 and 28 % on a dry basis. Operate the appliance at a medium burn rate (Category II or III) for at least 10 h for non-catalytic appliances and 50 h for catalytic appliances. Record and report hourly flue gas exit temperature data and the hours of operation. The aging procedure shall be conducted and documented by a testing laboratory.

12. Procedure

12.1 *Appliance Installation*—Assemble the appliance and parts in conformance with the manufacturer's written installation instructions. Clean the flue with an appropriately sized, wire chimney brush before each certification test series.

12.2 Cordwood Fueled Appliances:

12.2.1 *Fuel*—Test fuel charge fuel shall be white or red oak cordwood 18 to 28 % moisture content—dry basis. Cord wood used shall be split on at least one face, have a maximum cross sectional dimension of 10 in. (254 mm) and a minimum cross sectional dimension, measured at the widest point on a line perpendicular to the longest cross section dimension, of 3 in. (76 mm). Only cordwood pieces that are free of decay, fungus,

and loose bark shall be used. All pieces selected shall weigh between 4.4 and 22 lb (2 to 10 kg). For each test fuel load at least 80 % of the load weight shall be comprised of fuel pieces weighing between 8 and 18 lb (3.6 and 8.2 kg). Piece length shall be 20 ± 4 in. (490 ± 102 mm). (See Fig. 3.) Pieces are to be placed in the firebox parallel to the longest firebox dimension or in the direction specified in the manufacturer's printed operating instructions. When loading test fuel loads, no effort shall be made to stack fuel pieces in a particular manner.

12.2.2 Moisture Content—Determine the test fuel moisture content with a calibrated electrical resistance moisture meter. Determine fuel moisture for each fuel piece by averaging at least three moisture meter readings, one from each of three sides, measured parallel to the wood grain. Measure the moisture content within 2 to 3 in. (50 to 75 mm) of each end and at the center of each piece. Average all the readings for each fuel piece in the test fuel charge. Penetration of the moisture meter insulated electrodes shall be at least 0.75 in. (19 mm). Measure the moisture content within a 4 h period prior to the test run.

12.2.3 Firebox Volume—Determine the firebox volume in cubic feet. Firebox volume shall include all areas accessible through the fuel loading door where firewood could reasonably be placed up to the horizontal plane defined by the top of the loading door. A drawing of the firebox showing front, side and plan views or an isometric view with interior dimensions shall be provided by the manufacturer and verified by the laboratory. Calculations for firebox volume from computer aided design (CAD) software programs are acceptable and shall be included in the test report if used. If the firebox volume is calculated by the laboratory the firebox drawings and calculations shall be included in the test report.

12.2.4 Test Fuel Charge—Test fuel charges shall be determined by multiplying the firebox volume by 10 lb (4.54 kg), or a higher load density as recommended by the manufacturer's printed operating instructions, of wood (as used wet weight)

per cubic foot. Select the number of pieces of fuel that most nearly match this target weight. When the manufacturer's printed instructions specify fuel loading to a specific level, the firebox shall be loaded with fuel as specified in 12.2.1 to the level indicated and the weight of the fuel load recorded. This weight shall then be divided by the firebox volume as determined in accordance with 12.2.3 and the resulting loading density shall be reported. If this loading density is less than 10 lb/ft³ (160 kg/m³), all tests shall be run with fuel load densities of 10 lb/ft³ (160 kg/m³) even though this could require loading to a level higher than indicated in the manufacturer's instructions.

12.2.5 Sampling Equipment—Prepare the sampling equipment as defined by Test Method E2515.

12.2.6 Appliance Start-Up—The appliance shall be fired with wood fuel of any species, size and moisture content at the laboratories discretion to bring it up to operating temperature. Operate the appliance until the water is heated to the upper operating control limit and has cycled at least two times. Then remove all unburned fuel, zero the scale, and verify the scales accuracy using dead weights.

12.2.7 Pretest Burn Cycle—Reload appliance with oak fuel wood and allow it to burn down to the specified coal bed weight. Pretest burn cycle fuel charge weight shall be within $\pm 10\%$ of the test fuel charge weight. At least 2 h prior to starting the test run, adjust water flow to the heat exchanger to establish the target heat draw for the test. For the first test run the heat draw rate shall be equal to the manufacturer's rated heat output capacity.

12.2.8 Allowable Adjustments—Fuel addition or subtractions, and coal bed raking shall be kept to a minimum but are allowed up to 15 min prior to the start of the test run. For the purposes of this method, coal bed raking is the use of a metal tool (poker) to stir coals, break burning fuel into smaller pieces and dislodge fuel pieces from positions of poor combustion. Record all adjustments to and additions or subtractions of fuel, and any other changes to the appliance operations that occur during pretest ignition period. During the 15-min period prior to the start of the test run, the appliance loading door shall not be open more than a total of 1 min. Coal bed raking is the only adjustment allowed during this period.

12.2.9 Coal Bed Weight—The appliance is to be loaded with the test fuel charge when the coal bed weight is between 10 and 20 % of the test fuel charge weight. Coals may be raked as necessary to level the coal bed or position coals as recommended in the manufacturer's printed operating instructions but may only be raked and stirred once between 15 to 20 min prior to the addition of the test fuel charge.

12.2.10 Test Cycle—Complete a test run in each heat output rate category, as follows:

12.2.10.1 Test Run Start—Once the appliance is operating normally and the pretest coal bed weight has reached the target value in accordance with 12.2.9, tare the scale, start all sampling systems and load the full test charge into the appliance. Time for loading shall not exceed 5 min. The actual weight of the test fuel charge shall be measured and recorded within 30 min prior to loading. Record all data at intervals of 10 min or less. Record water flow and temperature data and

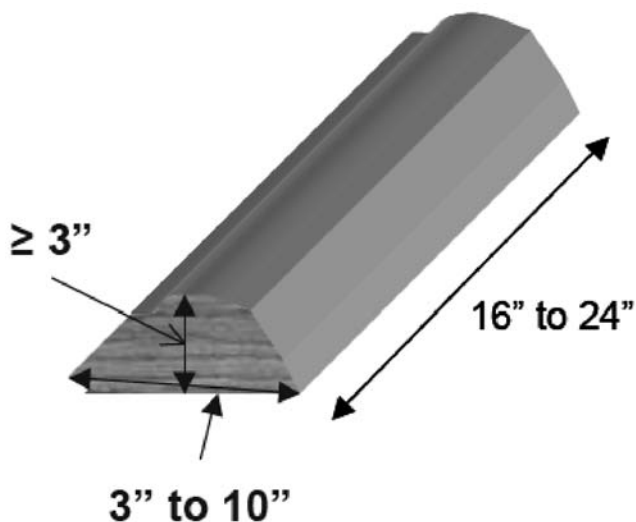

FIG. 3 Cord Wood Fuel

monitor the average heat output rate. If the heat output rate gets close to the upper or lower limit of the target range adjust the water flow through the heat exchanger to compensate. Make changes as infrequently as possible while maintaining the target heat output rate. The first test run shall be conducted at the Category IV heat output rate to validate that the appliance is capable of producing the manufacturer's rated heat output capacity.

12.2.10.2 Test Fuel Charge Adjustment—It is acceptable to adjust the test fuel charge (that is, reposition) once during a test run if more than 60 % of the initial test fuel charge weight has been consumed and more than 10 min have elapsed without a measurable (1 lb (0.5 kg) or 1 % of the test fuel load weight, whichever is greater) weight change while the operating control is in the demand mode. The time used to make this adjustment shall be less than 60 s.

12.2.10.3 Test Run Completion—The test run is completed when the remaining weight of the test fuel charge is 0.0 lb (0.0 kg). End the test run when the scale has indicated a test fuel charge weight of 0.0 lb (0.0 kg) or less for 30 s. At the end of the test run, stop the particulate sampling and record the run time and all final measurement values.

12.2.11 Heat Output Capacity Validation—The first test run must produce a heat output rate that is within 10 % of the manufacturer's rated heat output capacity (Category IV). If the appliance is not capable of producing a heat output within these limits, the manufacturer's rated heat output capacity is considered not validated and testing is to be terminated. In such cases, the tests may be continued using the heat output capacity as measured as the Manufacturer's Rated Heat Output Capacity if requested by the manufacturer.

12.2.12 Additional Test Runs—Using the Manufacturer's Rated Heat Output Capacity as a basis, conduct a test for additional heat output categories as specified in 4.3. It is not required to run these tests in any particular order.

12.2.13 Alternative Heat Output Rate for Category I—If an appliance cannot be operated in the Category I heat output range due to stopped combustion two test runs shall be conducted at heat output rates within Category II. When this is the case, the weightings for the weighted averages indicated in 14.1.14 shall be the average of the Category I and II weightings and shall be applied to both Category II results. Appliances that are not capable of operation within Category II (<25 % of maximum) cannot be evaluated by this test method.

12.2.14 Stopped Fuel Combustion—Evidence that an appliance cannot be operated at a Category I heat output rate due to stopped fuel combustion shall include documentation of two or more attempts to operate the appliance in burn rate Category I and fuel combustion has stopped prior to complete consumption of the test fuel charge. Stopped fuel combustion is evidenced when an elapsed time of 60 min or more has occurred without a measurable (1 lb (0.5 kg) or 1 % of the test load weight, whichever is greater) weight change in the test fuel charge while the appliance operating control is in the demand mode. Report the evidence and the reasoning used to determine that a test in burn rate Category I cannot be achieved. For example, two unsuccessful attempts to operate at

an output rate of 10 % of the rated output capacity are not sufficient evidence that burn rate Category I cannot be achieved.

12.2.15 Appliance Overheating—Appliances shall be capable of operating in all heat output categories without overheating to be rated by this test method. Appliance overheating occurs when the rate of heat withdrawal from the appliance is lower than the rate of heat production when the unit control is in the idle mode. This condition results in the water in the appliance continuing to increase in temperature well above the upper limit setting of the operating control. Evidence of overheating includes: 1 h or more of appliance water temperature increase above the upper temperature setpoint of the operating control, exceeding the temperature limit of a safety control device (independent from the operating control), boiling water in a non-pressurized system or activation of a pressure or temperature relief valve in a pressurized system.

12.2.16 Additional Test Runs—The testing laboratory may conduct more than one test run in each of the heat output categories specified in 4.3. If more than one test run is conducted at a specified heat output rate, the results from at least two thirds of the test runs in that heat output rate category shall be used in calculating the weighted average emission rate (see 14.1.14). The measurement data and results of all test runs shall be reported regardless of which values are used in calculating the weighted average emission rate.

12.3 Automatically Fueled Appliances:

12.3.1 Appliances designed to burn automatically fed fuels such as wood pellets, shelled corn, wood chips or other biomass shall be tested using the fuel or fuels specified in the manufacturer's operating instructions.

12.3.2 Operation—The fuel used shall have representative samples taken and tested for higher heating value in accordance with Test Method E711 and for moisture content by the oven drying method (Test Methods D4442, Method A or B). Sufficient fuel for the tests shall be placed in a hopper on a scale that allows for measurement of the mass of fuel consumed during the test runs to an accuracy of ± 1 lb (± 0.5 kg). The unit shall be set up and operated in accordance with the manufacturer's instructions. A heat exchanger as specified in Section 9 shall be used to draw heat from the appliance at the rates specified for the categories specified in 4.3. The unit shall be operated for a minimum of 2 h at the specified heat output rate prior to starting the measurement phase of the test.

12.3.3 Measurement Phase—Record the weight of the fuel in the hopper after the unit has been in operation at the specified heat draw rate for 2 h. Start the emissions measurement sampling train and data collection as required in Test Method E2515. Continue operation for a minimum of 4 h. At the end of the test period, stop the sampling train and record the final weight of the fuel in the hopper. Calculate the emissions, efficiency and heat output rate as specified in Section 13 using the mass of fuel consumed and the higher heating value for the fuel. Repeat this procedure for each heat output rate category. If more than one fuel type is specified, repeat the entire rating procedure for each fuel type.