

---

# INTERNATIONAL STANDARD



# 2031

---

INTERNATIONAL ORGANIZATION FOR STANDARDIZATION • МЕЖДУНАРОДНАЯ ОРГАНИЗАЦИЯ ПО СТАНДАРТИЗАЦИИ • ORGANISATION INTERNATIONALE DE NORMALISATION

---

## Granulated cork — Bulk density test

First edition — 1972-03-15

**iTeh STANDARD PREVIEW**  
**(standards.iteh.ai)**

ISO 2031:1972

<https://standards.iteh.ai/catalog/standards/sist/25f37442-6e70-427a-b3a2-ceedb947ef8b/iso-2031-1972>

87

M<sub>1000</sub> (F)  
2x(E)

---

UDC 674.83 — 492.3 : 531.754

Ref. No. ISO 2031-1972 (E)

**Descriptors** : bulk density, cork, granular materials, physical tests.

## FOREWORD

ISO (the International Organization for Standardization) is a worldwide federation of national standards institutes (ISO Member Bodies). The work of developing International Standards is carried out through ISO Technical Committees. Every Member Body interested in a subject for which a Technical Committee has been set up has the right to be represented on that Committee. International organizations, governmental and non-governmental, in liaison with ISO, also take part in the work.

Draft International Standards adopted by the Technical Committees are circulated to the Member Bodies for approval before their acceptance as International Standards by the ISO Council.

International Standard ISO 2031 was drawn up by Technical Committee ISO/TC 87, *Cork*.

It was approved in November 1970 by the Member Bodies of the following countries:

Bulgaria	Iran	Spain
Czechoslovakia	Italy	U.A.R.
France	Portugal	United Kingdom
Greece	South Africa, Rep. of	

[ISO 2031:1972](https://standards.iteh.ai/catalog/standards/sist/25f37442-6e70-427a-b3a2-ceedeb917af8b/iso-2031-1972)

<https://standards.iteh.ai/catalog/standards/sist/25f37442-6e70-427a-b3a2-ceedeb917af8b/iso-2031-1972>

No Member Body opposed the approval of the Draft.

# Granulated cork – Bulk density test

## 1 SCOPE AND FIELD OF APPLICATION

This International Standard specifies a method of determining the bulk density of granulated cork.

## 2 REFERENCES

ISO 1997, *Granulated cork and cork powder – Specifications*.

ISO/R 2067, *Granulated cork – Sampling*.

## 3 APPARATUS

**3.1 Balance**, accurate to 0.5 g, capacity 2 kg.

**3.2 Oven**, capable of maintaining a temperature of  $20 \pm 2^\circ\text{C}$  and a relative humidity of  $65 \pm 5\%$ .

**3.3 Cubic container**, capacity  $2\text{ dm}^3$  (side 126 mm) (No. 4 in the Figure.)

**3.4 Cubic container**, capacity  $1\text{ dm}^3$ . (No. 4 in the Figure.)

**3.5 Wooden ruler**.

**3.6 Stand** for the hopper, with a height such that the upper rim of the hopper is 450 mm away from the supporting surface. (No. 3 in the Figure.)

**3.7 Conical hopper** (No. 1 in the Figure), with upper and lower diameters of 300 mm and 70 mm respectively, at a distance of 200 mm from each other.

The top of the hopper is open; the base ends in a cylindrical tube 50 mm high and has a removable bottom (No. 2 in the Figure).

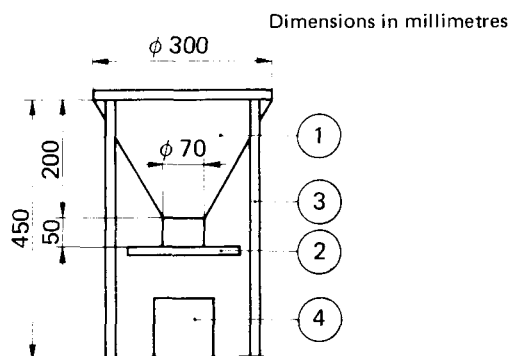

FIGURE – Apparatus

## 4 SAMPLING

Follow the instructions given in ISO/R 2067.

## 5 PROCEDURE

### 5.1 Preparation of sample

Condition the sample at a temperature of  $20 \pm 2^\circ\text{C}$  and a relative humidity of  $65 \pm 5\%$ , keeping it in the oven (3.2) for 24 h.

### 5.2 Test portion

After conditioning the sample, take at random a test portion of about 400 g for granulated cork of classes 1 to 4, and of 200 g for granulated cork of classes 5 to 8 (see ISO 1997).

### 5.3 Determination

Hang the hopper (3.7) on the stand (3.6). Place the container (3.3) or (3.4), depending on whether the granulated cork being tested belongs to classes 1 to 4 or to classes 5 to 8, under the base of the hopper (3.7) and on the supporting surface of the stand (3.6).

Close the base of the hopper (3.7) and pour the test portion to fill the hopper.

Open completely the bottom of the hopper (3.7) and allow all the granulated cork to fall into the container (3.3) or (3.4). Use the ruler (3.5) to level the top.

Take the granulated cork from the container and weigh it on the balance (3.1).

Carry out five tests, each time with the same test portion, according to section 5.

## 6 EXPRESSION OF RESULTS

Bulk density, expressed in kilogrammes per cubic metre, is equal to

$$\frac{m}{2} \quad \text{for granulated cork of classes 1 to 4}$$

$$m \quad \text{for granulated cork of classes 5 to 8}$$

where  $m$  is the mass, in grammes, rounded to the nearest whole number, of the granulated cork taken from container (3.3) or (3.4).

Take as the result the arithmetic mean of the five determinations.

Round the result to the nearest whole number.

**7 TEST REPORT**

The test report shall include the following particulars:

- a) the test results;
- b) details of procedures not specified in this International

Standard or considered as optional;

- c) any incidents that may have affected the results;
- d) all information necessary for the complete identification of the sample.

---

**iTeh STANDARD PREVIEW**  
**(standards.iteh.ai)**

ISO 2031:1972

<https://standards.iteh.ai/catalog/standards/sist/25f37442-6e70-427a-b3a2-ceedb947ef8b/iso-2031-1972>