

DRAFT INTERNATIONAL STANDARD

ISO/DIS 23233

ISO/TC 45/SC 2

Secretariat: JISC

Voting begins on:
2015-06-19

Voting terminates on:
2015-09-19

Rubber, vulcanized or thermoplastic — Determination of resistance to abrasion using a driven, vertical abrasive disc

Caoutchouc, vulcanisé ou thermoplastique — Détermination de la résistance à l'abrasion au moyen d'un disque abrasif vertical, motorisé

ICS: 83.060

iTeh STANDARD PREVIEW
(standards.iteh.ai)

Full standard:
<https://standards.iteh.ai/catalog/standards/sist/039292a1-94ea-4629-b339-bf64df48a3f6/iso-23233-2016>

THIS DOCUMENT IS A DRAFT CIRCULATED FOR COMMENT AND APPROVAL. IT IS THEREFORE SUBJECT TO CHANGE AND MAY NOT BE REFERRED TO AS AN INTERNATIONAL STANDARD UNTIL PUBLISHED AS SUCH.

IN ADDITION TO THEIR EVALUATION AS BEING ACCEPTABLE FOR INDUSTRIAL, TECHNOLOGICAL, COMMERCIAL AND USER PURPOSES, DRAFT INTERNATIONAL STANDARDS MAY ON OCCASION HAVE TO BE CONSIDERED IN THE LIGHT OF THEIR POTENTIAL TO BECOME STANDARDS TO WHICH REFERENCE MAY BE MADE IN NATIONAL REGULATIONS.

RECIPIENTS OF THIS DRAFT ARE INVITED TO SUBMIT, WITH THEIR COMMENTS, NOTIFICATION OF ANY RELEVANT PATENT RIGHTS OF WHICH THEY ARE AWARE AND TO PROVIDE SUPPORTING DOCUMENTATION.



Reference number
ISO/DIS 23233:2015(E)

© ISO 2015

iTeh STANDARD PREVIEW
(standards.iteh.ai)
Full standard:
<https://standards.iteh.ai/catalog/standards/sist/039292a1-94ea-4629-b339-bf64df48a3f6/iso-23233-2016>



COPYRIGHT PROTECTED DOCUMENT

© ISO 2015, Published in Switzerland

All rights reserved. Unless otherwise specified, no part of this publication may be reproduced or utilized otherwise in any form or by any means, electronic or mechanical, including photocopying, or posting on the internet or an intranet, without prior written permission. Permission can be requested from either ISO at the address below or ISO's member body in the country of the requester.

ISO copyright office
Ch. de Blandonnet 8 • CP 401
CH-1214 Vernier, Geneva, Switzerland
Tel. +41 22 749 01 11
Fax +41 22 749 09 47
copyright@iso.org
www.iso.org

Contents

Page

Foreword	iv
1 Scope	1
2 Normative references	1
3 Terms and definitions	2
4 Principle	2
5 Apparatus	3
5.1 Abrasion test machine	3
5.2 Balance	5
6 Test pieces	5
6.1 Type and preparation	5
6.2 Number	5
6.3 Time interval between vulcanization or forming and testing	6
7 Conditioning	6
8 Test temperature	6
9 Test conditions	6
9.1 Preliminary abrasion	6
9.2 Run-in	6
9.3 Test conditions	7
10 Procedure	8
10.1 Order of the test pieces	8
10.2 Marking of the test pieces	8
10.3 Abrasion testing	8
11 Expression of results ^{[1] to [5]}	9
12 Test report	9
Bibliography	11

Foreword

ISO (the International Organization for Standardization) is a worldwide federation of national standards bodies (ISO member bodies). The work of preparing International Standards is normally carried out through ISO technical committees. Each member body interested in a subject for which a technical committee has been established has the right to be represented on that committee. International organizations, governmental and non-governmental, in liaison with ISO, also take part in the work. ISO collaborates closely with the International Electrotechnical Commission (IEC) on all matters of electrotechnical standardization.

International Standards are drafted in accordance with the rules given in the ISO/IEC Directives, Part 2.

The main task of technical committees is to prepare International Standards. Draft International Standards adopted by the technical committees are circulated to the member bodies for voting. Publication as an International Standard requires approval by at least 75 % of the member bodies casting a vote.

Attention is drawn to the possibility that some of the elements of this document may be the subject of patent rights. ISO shall not be held responsible for identifying any or all such patent rights.

ISO 23233 was prepared by Technical Committee ISO/TC 45, *Rubber and rubber products*, Subcommittee SC 2, *Testing and analysis*.

This second edition cancels and replaces the first edition (ISO 23233:2009), which has been revised to update the dimensions of the test piece and the test conditions.

Standard PREVIEW
(standards.iteh.ai)
Full standards catalog/standards/sist/18292a1-94ea-4629-b339-bf64df48a3f6/iso-23233-2009-2a1-
https://standards.iteh.ai/catalog/standards/sist/18292a1-94ea-4629-b339-bf64df48a3f6/iso-23233-2009-2a1-

Rubber, vulcanized or thermoplastic — Determination of resistance to abrasion using a driven, vertical abrasive disc

WARNING 1 — Persons using this International Standard should be familiar with normal laboratory practice. This standard does not purport to address all of the safety problems, if any, associated with its use. It is the responsibility of the user to establish appropriate safety and health practices and to ensure compliance with any national regulatory conditions.

WARNING 2 — Certain procedures specified in this International Standard may involve the use or generation of substances, or the generation of waste, that could constitute a local environmental hazard. Reference should be made to appropriate documentation on safe handling and disposal after use.

1 Scope

This International Standard specifies a method for the determination of the resistance of rubber to abrasion using a driven, vertical abrasive disc (the LAT 100: Laboratory Abrasion Tester 100).

The loss in mass on abrasion is determined through the slip caused by setting different slip angles and rotational speeds between a wheel-shaped rubber test piece and an abrasive disc which are rotating in planes at right angles to each other and pressed against each other with a specified load. The test result can be reported as the loss in mass per unit running distance and/or as an abrasion resistance index compared to a reference compound.

This International Standard is applicable to comparative testing, quality control, specification compliance testing, referee testing and research and development work.

As the test device described is capable of setting each abrasion parameter, such as slip angle, rotational speed of the abrasive disc and load, independently, the method is suitable for carrying out a wide range of abrasion tests for various rubber products, especially tyres.

2 Normative references

The following referenced documents are indispensable for the application of this document. For dated references, only the edition cited applies. For undated references, the latest edition of the referenced document (including any amendments) applies.

ISO 525, *Bonded abrasive products — General requirements*

ISO 8486-1, *Bonded abrasives — Determination and designation of grain size distribution — Part 1: Macrogrits F4 to F220*

ISO 23529, *Rubber — General procedures for preparing and conditioning test pieces for physical test methods*

3 Terms and definitions

For the purposes of this document, the following terms and definitions apply.

3.1

abrasion

loss of material from a surface due to frictional forces

[ISO 23794]

3.2

abrasion resistance

resistance to wear resulting from mechanical action upon a surface

[ISO 23794]

Note 1 to entry Abrasion resistance can be expressed as a loss in mass or an abrasion resistance index.

3.3

abrasion resistance index

ratio of the loss in volume of a reference compound to the loss in volume of a test rubber measured under the same specified conditions and expressed as a percentage

[ISO 23794]

Note 1 to entry The smaller the number, the lower the abrasion resistance.

3.4

slip angle

angle made by the plane of the test piece with the radius of the abrasive disc which passes through the point of contact between the test piece and the abrasive disc

3.5

running distance

total distance travelled by a point on the circumference of the test piece relative to the abrasive disc

3.6

reference compound

compound of known abrasion resistance which is compared with that of the test rubber

4 Principle

A wheel-shaped test piece and an abrasive disc are pressed against each other at right angles by a specified load. The abrasive disc is driven so that it rotates, causing the test piece to rotate with it. Wear occurs due to slip between the test piece and the abrasive disc.

Different angles of slip between the abrasive disc and the test piece can be used to give different speeds of rotation of the test piece.

A powder consisting of a mixture of MgO and Al₂O₃ is used to prevent smearing of the test piece on the surface of the abrasive disc.

The loss in mass of the test piece is measured and the loss per unit running distance calculated. The abrasion resistance index can also be determined by comparing the loss in mass of the test piece per unit running distance with the loss in mass per unit running distance of a reference compound tested under the same conditions.

5 Apparatus

5.1 Abrasion test machine

The abrasion test machine (see Figure 1) consists of an abrasive electro-corundum disc, a test piece holder with test piece mounting facilities (see Figure 2), a feed device for anti-smearing powder, an infrared thermometer, a load application device, a slip angle adjustment device and a side force measurement device.

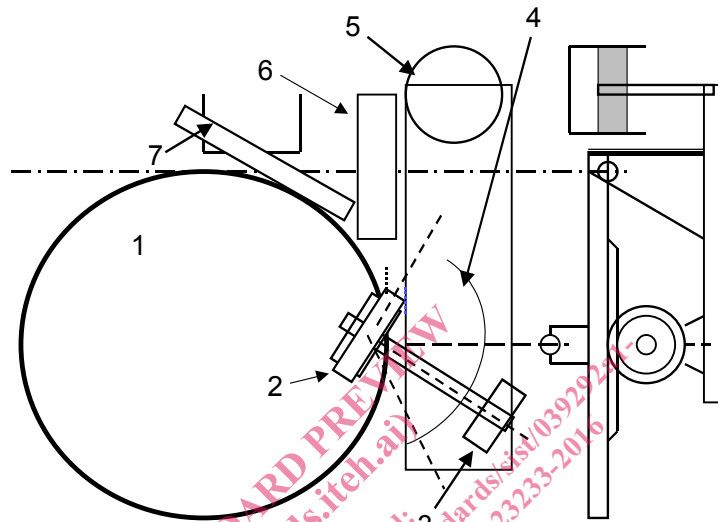

Key

- | | | | |
|---|--------------------------------------|---|---------------------------|
| 1 | electro-corundum disc | 5 | load application device |
| 2 | test piece | 6 | infrared thermometer |
| 3 | side force measurement device | 7 | anti-smearing powder feed |
| 4 | slip angle adjustable from 0° to 20° | | |

Figure 1 — Schematic illustration of the apparatus

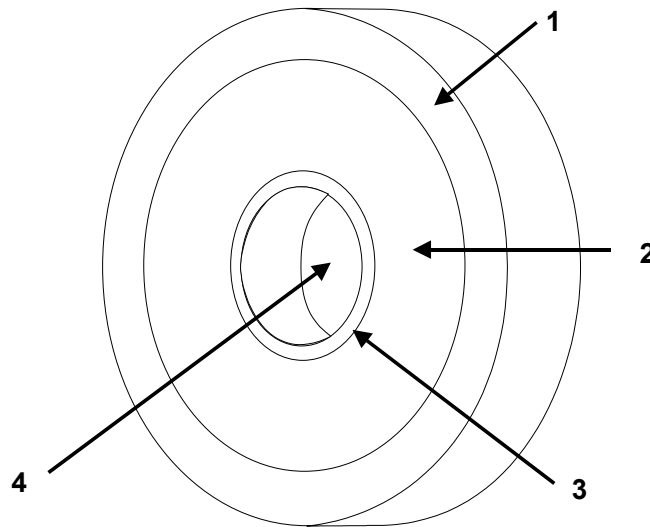

Key

- 1 test piece (external diameter: see Table 2, internal diameter: see Table 2)
- 2 steel support discs, one on each side (external diameter: 60 mm, internal diameter: maximum highest 35 mm)
- 3 sleeve (external diameter: 35 mm, internal diameter: 30 mm)
- 4 bore for mounting shaft (diameter: 30 mm)

Figure 2 — Test piece mounted on the test piece holder

The test piece shall be mounted in such a way that it does not slip on its mounting shaft when the abrasive disc is rotated, so that the rotation of the abrasive disc is accurately transmitted to the test piece. A pair of 60 mm diameter support discs with a maximum highest 35 mm bore at the centre shall be fitted on each side of the test piece to ensure the lateral rigidity of the test piece core (see Figure 2). Furthermore, a sleeve having an internal diameter of 30 mm, an external diameter of 35 mm and a length of 15 mm shall be inserted into the bore of the test piece to fix it securely on the mounting shaft.

The abrasive disc shall be mounted in such a way that it does not slip on the mounting shaft when torque is applied, so that the rotation of the shaft is accurately transmitted to the disc. The specifications of the abrasive disc shall be based on ISO 525: abrasive A (in this case electro-corundum), grit size 60 (equivalent to the designation F60 specified in ISO 8486-1), hardness grade I, nature of bond V (vitrified bond) and structure 8 (very open). The diameter of the abrasive disc shall be 350 mm and its thickness 25 mm.

The drive mechanism for the abrasive disc shall have a motor capable of controlling the circumferential speed of the disc in the range from 2,0 km/h to 30,0 km/h.

The apparatus shall be fitted with a loading mechanism to press the test piece against the abrasive disc with a force of 75 N during the test, regardless of the combination of disc speed and slip angle. The slip angle setting shall be variable in the range from 0° to 20°.

The apparatus shall also be fitted with a feed mechanism to drop anti-smearing powder at a specified rate into the area of contact between the test piece and the abrasive disc. The feed rate shall be adjustable over the range between 0 units and 100 units, corresponding to 0 g/min to 75 g/min on a non-linear scale (see Table 1). The anti-smearing powder shall consist of a mixture of 2 parts by volume of Al₂O₃ (electro-corundum, grain size 120) and 1 part by volume of MgO (heavy, bulk density ≈ 675 g/l, type 90, grain size 120).

Table 1 — Anti-smearing powder feed rate

Feed rate in units	Feed rate in g/min
1	0,07
2	0,13
5	0,37
10	0,96
15	1,66
20	2,31
40	10,76
60	34,65
80	55,61
100	75,17

NOTE The powder feed rate used during the test is chosen to ensure that the surfaces of the abrasive disc and the test piece are cleaned efficiently (see Table 3).

5.2 Balance

The balance used shall be of sufficient accuracy to enable the loss in mass of the test piece to be determined to within $\pm 0,1$ mg.

6 Test pieces

6.1 Type and preparation

Test pieces shall be in the form of a disc having the dimensions **in accordance to the conditions** shown in Table 2. They shall be prepared by moulding or by cutting from a finished product, which may be either vulcanized or thermoplastic, using a rotary cutter. The abrasion surface of test pieces shall be smooth, without any pattern.

Table 2 — Dimensions of test piece

Type of test piece	Inner diameter mm	Outer diameter mm	Thickness mm
Type A (prepared by moulding)	approx. 35 (arising by a vulcanisation mould with an inner diameter of 35 mm)	approx. 84 (arising by a vulcanisation mould with an inner diameter of 84 mm)	$19 \pm 0,5$
Type B (prepared by cutting of a finished product)	35	84	$19 \pm 0,5$

6.2 Number

One test piece shall be used for each compound tested, but the reference material shall be tested in duplicate.