

---

---

**Mechanical vibration — Vibration of  
rotating machinery equipped with  
active magnetic bearings —**

**Part 1:  
Vocabulary**

*Vibrations mécaniques — Vibrations de machines rotatives équipées  
de paliers magnétiques actifs —*

*Partie 1: Vocabulaire*

**Document Preview**

ISO 14839-1:2018

<https://standards.iteh.ai/catalog/standards/iso/6e64b306-38b7-4efc-bf82-cd5a0837e37d/iso-14839-1-2018>



iTeh Standards  
(<https://standards.iteh.ai>)  
Document Preview

[ISO 14839-1:2018](https://standards.iteh.ai/catalog/standards/iso/6e64b306-38b7-4efc-bf82-cd5a0837e37d/iso-14839-1-2018)

<https://standards.iteh.ai/catalog/standards/iso/6e64b306-38b7-4efc-bf82-cd5a0837e37d/iso-14839-1-2018>



**COPYRIGHT PROTECTED DOCUMENT**

© ISO 2018

All rights reserved. Unless otherwise specified, or required in the context of its implementation, no part of this publication may be reproduced or utilized otherwise in any form or by any means, electronic or mechanical, including photocopying, or posting on the internet or an intranet, without prior written permission. Permission can be requested from either ISO at the address below or ISO's member body in the country of the requester.

ISO copyright office  
CP 401 • Ch. de Blandonnet 8  
CH-1214 Vernier, Geneva  
Phone: +41 22 749 01 11  
Fax: +41 22 749 09 47  
Email: [copyright@iso.org](mailto:copyright@iso.org)  
Website: [www.iso.org](http://www.iso.org)

Published in Switzerland

# Contents

	Page
<b>Foreword</b> .....	<b>iv</b>
<b>1 Scope</b> .....	<b>1</b>
<b>2 Normative references</b> .....	<b>1</b>
<b>3 Terms and definitions</b> .....	<b>1</b>
3.1 General terms.....	1
3.2 Terms relating to rotors.....	10
3.3 Terms relating to stators.....	10
3.4 Terms relating to position transducers.....	11
3.5 Terms relating to dynamics, control and electronics.....	13
3.6 Terms relating to auxiliary equipment.....	17
<b>Bibliography</b> .....	<b>19</b>
<b>Alphabetical index</b> .....	<b>20</b>

iTeh Standards  
(<https://standards.itih.ai>)  
Document Preview

[ISO 14839-1:2018](#)

<https://standards.itih.ai/catalog/standards/iso/6e64b306-38b7-4efc-bf82-cd5a0837e37d/iso-14839-1-2018>

## Foreword

ISO (the International Organization for Standardization) is a worldwide federation of national standards bodies (ISO member bodies). The work of preparing International Standards is normally carried out through ISO technical committees. Each member body interested in a subject for which a technical committee has been established has the right to be represented on that committee. International organizations, governmental and non-governmental, in liaison with ISO, also take part in the work. ISO collaborates closely with the International Electrotechnical Commission (IEC) on all matters of electrotechnical standardization.

The procedures used to develop this document and those intended for its further maintenance are described in the ISO/IEC Directives, Part 1. In particular the different approval criteria needed for the different types of ISO documents should be noted. This document was drafted in accordance with the editorial rules of the ISO/IEC Directives, Part 2 (see [www.iso.org/directives](http://www.iso.org/directives)).

Attention is drawn to the possibility that some of the elements of this document may be the subject of patent rights. ISO shall not be held responsible for identifying any or all such patent rights. Details of any patent rights identified during the development of the document will be in the Introduction and/or on the ISO list of patent declarations received (see [www.iso.org/patents](http://www.iso.org/patents)).

Any trade name used in this document is information given for the convenience of users and does not constitute an endorsement.

For an explanation on the voluntary nature of standards, the meaning of ISO specific terms and expressions related to conformity assessment, as well as information about ISO's adherence to the World Trade Organization (WTO) principles in the Technical Barriers to Trade (TBT) see the following URL: [www.iso.org/iso/foreword.html](http://www.iso.org/iso/foreword.html).

This document was prepared by Technical Committee ISO/TC 108, *Mechanical vibration, shock and condition monitoring*, Subcommittee SC 2, *Measurement and evaluation of mechanical vibration and shock as applied to machines, vehicles and structures*.

This second edition cancels and replaces the first edition (ISO 14839-1:2002), which has been technically revised. It also incorporates the Amendment ISO 14839-1:2002/Amd. 1:2010.

The main change compared to the previous edition is as follows:

- the terms have been updated and revised to reflect how they are used in practice.

A list of all parts in the ISO 14839 series can be found on the ISO website.

Any feedback or questions on this document should be directed to the user's national standards body. A complete listing of these bodies can be found at [www.iso.org/members.html](http://www.iso.org/members.html).

# Mechanical vibration — Vibration of rotating machinery equipped with active magnetic bearings —

## Part 1: Vocabulary

### 1 Scope

This document defines terms relating to rotating machinery equipped with active magnetic bearings.

NOTE General terms and definitions of mechanical vibration are given in ISO 2041; those relating to balancing are given in ISO 21940-2; those relating to geometric characteristics such as coaxiality, concentricity and runout are explained in ISO 1101.

### 2 Normative references

There are no normative references in this document.

### 3 Terms and definitions

ISO and IEC maintain terminological databases for use in standardization at the following addresses:

- ISO Online browsing platform: available at <https://www.iso.org/obp>
- IEC Electropedia: available at <http://www.electropedia.org/>

#### 3.1 General terms

##### 3.1.1

##### **levitation**

maintaining the position of a rotor by attractive or repulsive magnetic forces without mechanical contact

##### 3.1.2

##### **magnetic bearing**

bearing which utilizes either attractive or repulsive magnetic forces for the *levitation* (3.1.1) and dynamic stabilization of a rotor

##### 3.1.3

##### **active magnetic bearing**

##### **AMB**

means of supporting a rotor, without mechanical contact, using only attractive magnetic forces based upon servo feedback technology which normally consists of transducers, electromagnets, *power amplifiers* (3.5.3), power supplies and controllers

Note 1 to entry: For rotating machinery equipped with active magnetic bearings, the graphical symbols for bearings are shown in [Figure 1](#).

Note 2 to entry: The principle of an active magnetic bearing is shown in [Figure 2](#).

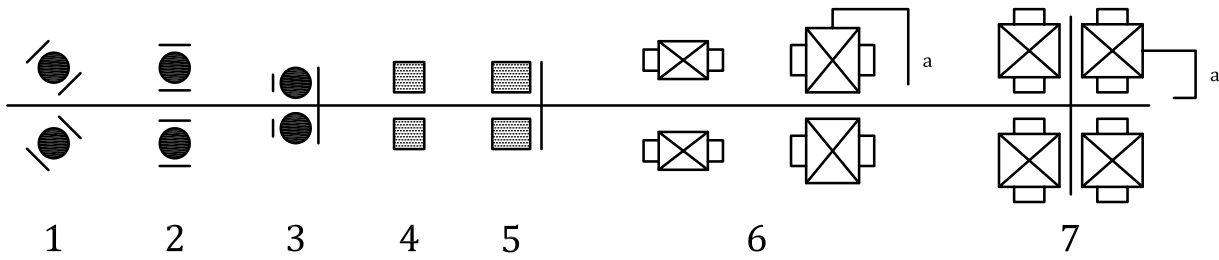

**Key**

- |   |                          |   |                                |
|---|--------------------------|---|--------------------------------|
| 1 | angular ball bearing     | 5 | thrust bushing                 |
| 2 | deep groove ball bearing | 6 | radial active magnetic bearing |
| 3 | thrust ball bearing      | 7 | axial active magnetic bearing  |
| 4 | radial bushing           |   |                                |
| a | With transducer.         |   |                                |

**Figure 1 — Graphical symbols for bearings**

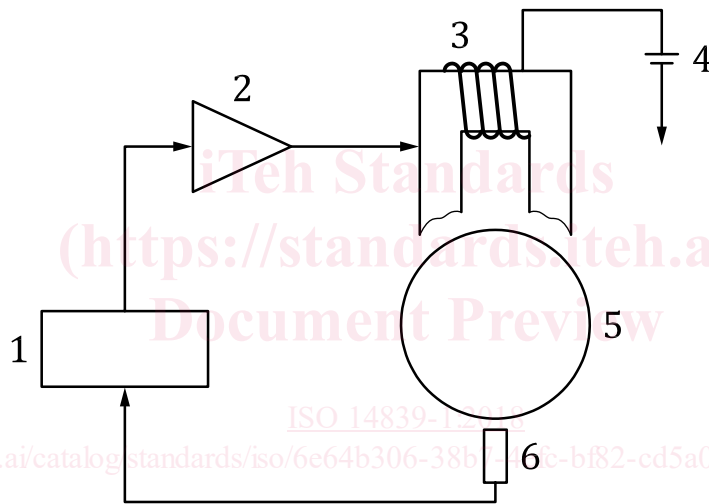

**Key**

- |   |                 |   |                         |
|---|-----------------|---|-------------------------|
| 1 | controller      | 4 | power supply            |
| 2 | power amplifier | 5 | rotor                   |
| 3 | electromagnet   | 6 | displacement transducer |

**Figure 2 — Principle of active magnetic bearing**

**3.1.4 passive magnetic bearing**

means of supporting a rotor, without mechanical contact, using magnetic forces without feedback control

EXAMPLE *Permanent magnetic bearing (3.1.5), super-conducting magnetic bearing (3.1.6).*

**3.1.5 permanent magnetic bearing**

**PMB**

*passive magnetic bearing (3.1.4) using one or several pairs of permanent magnets without feedback control*

### 3.1.6 super-conducting magnetic bearing SMB

*passive magnetic bearing* (3.1.4) using a pair of (high-temperature) super conductors and permanent magnets without feedback control, utilizing the so-called pinning force (attractive and repulsive forces)

### 3.1.7 hybrid magnetic bearing HMB

bearing consisting of any combination of an *active magnetic bearing* (3.1.3) and *passive magnetic bearing* (3.1.4)

### 3.1.8 permanent-magnet-biased AMB

*active magnetic bearing* (3.1.3) in which the nominal (non-zero) or bias magnetic fluxes are established by one or more permanent magnets

### 3.1.9 radial magnetic bearing

*magnetic bearing* (3.1.2) which levitates a rotor in the radial direction and supports it against disturbances in the radial direction, such as unbalance forces, fluid forces or gravity

Note 1 to entry: See [Figure 3](#).

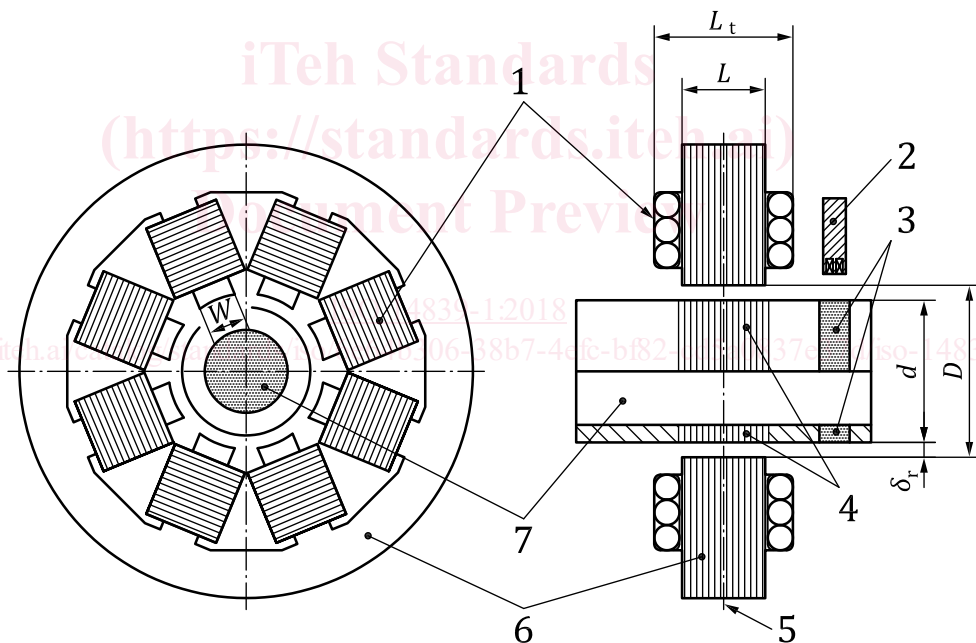

#### Key

1	radial coil	$D$	inner diameter of radial stator core
2	radial transducer	$d$	outer diameter of radial rotor core
3	radial transducer target	$\delta_r$	nominal magnetic gap $(D - d)/2$
4	radial rotor core	$L_t$	total bearing length (including coil windings)
5	axial centre of radial AMB	$L$	effective length of radial bearing
6	radial stator core	$W$	width of a magnetic pole
7	shaft	$A_r$	area of magnetic pole ( $A_r = WL$ )

Figure 3 — Radial AMB assembly

**3.1.10 axial magnetic bearing  
thrust magnetic bearing**

*magnetic bearing (3.1.2)* which levitates a rotor in the axial direction and supports it against disturbances in the axial direction, such as fluid forces or gravity

Note 1 to entry: See [Figure 4](#).

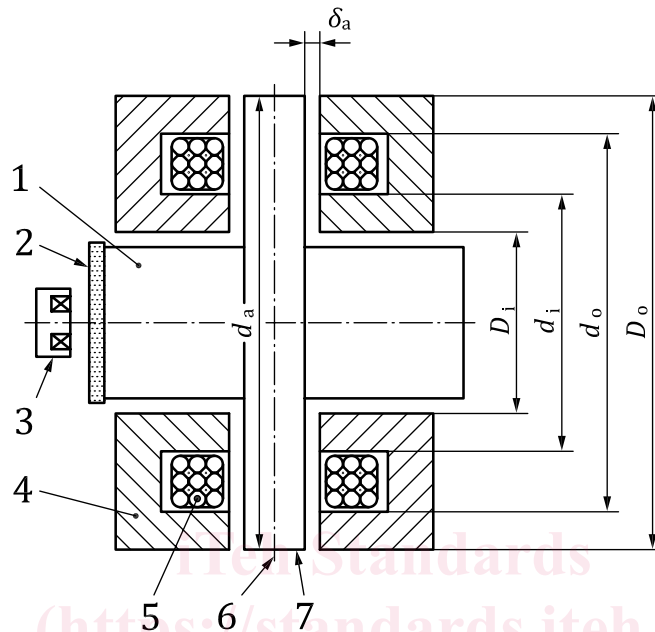

**Key**

- |   |                                 |            |  |
|---|---------------------------------|------------|--|
| 1 | rotor                           | $d_a$      | outer diameter of axial rotor disc           |
| 2 | axial transducer target         | $D_o$      | outer diameter of outer pole of axial stator |
| 3 | axial transducer                | $d_o$      | inner diameter of outer pole of axial stator |
| 4 | axial stator core               | $d_i$      | outer diameter of inner pole of axial stator |
| 5 | axial coil                      | $D_i$      | inner diameter of inner pole of axial stator |
| 6 | (clearance) centre of axial AMB | $\delta_a$ | nominal magnetic gap                         |
| 7 | axial rotor disc                | $A_a$      | area of the magnetic pole pair               |

$$A_a = \frac{\pi}{4} (D_o^2 - d_o^2 + d_i^2 - D_i^2)$$

**Figure 4 — Axial AMB assembly**

**3.1.11 nominal magnetic gap**

distance between the magnetic materials of the rotor and the stator inside the *AMB (3.1.3)* when the journal centre of the rotor is located in the clearance centre of the bearing stator

Note 1 to entry: See  $\delta_r$  in [Figure 3](#) for radial AMB, and  $\delta_a$  in [Figure 4](#) for axial AMB.

**3.1.12 clearance centre of a radial AMB**  
geometric centre of a radial bearing stator

Note 1 to entry: See [Figure 5](#).

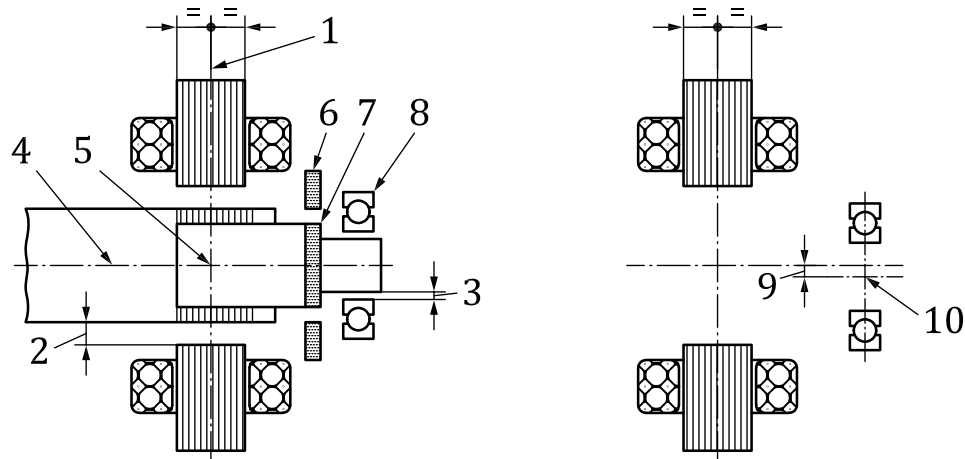

**Key**

1	axial centre of radial AMB	7	radial transducer target
2	magnetic gap of radial AMB	8	touch-down bearing
3	radial clearance of touch-down bearing	9	radial centre offset between radial touch-down bearing and AMB centre
4	journal (rotor) centreline of radial AMB	10	radial centre of radial touch-down bearing
5	clearance centreline of radial AMB		
6	radial transducer		

NOTE Similar consideration applies to a radial homopolar AMB.

**Figure 5 — Centres and centrelines of radial heteropolar AMB**

**3.1.13****magnetic centre of a radial AMB**

position of a rotor in a radial *AMB* (3.1.3) at which the net radial attractive forces exerted on the rotor go to zero for nominal currents or fluxes, and without any magnetic excitation or compensation forces

**3.1.14****axial centre of a radial AMB**

axial directional position of geometric centre of *stator core* (3.3.1)

Note 1 to entry: See [Figure 5](#).

**3.1.15****clearance centre of an axial AMB****clearance centre of a thrust AMB**

axial position of the geometric centre of an (axial) thrust *AMB* (3.1.3) stator

Note 1 to entry: See [Figure 4](#).

**3.1.16****axial magnetic centre of an axial AMB**

position of an *axial rotor disc* (3.2.2) in an axial *AMB* (3.1.3) at which the net axial attractive forces exerted on the rotor disc go to zero for nominal currents or fluxes, and without any magnetic excitation or compensation forces

**3.1.17****clearance centreline of a radial AMB**

line between the clearance centres of two radial *AMBs* (3.1.3) specified by the bearing stator configuration

Note 1 to entry: See [Figure 5](#).

**3.1.18**

**journal centreline of a radial AMB**

geometric centreline between the journal centres of a radial AMB (3.1.3) rotor

Note 1 to entry: See Figure 5.

**3.1.19**

**bearing span between radial AMBs**

axial distance between the axial centres of two radial AMBs (3.1.3)

Note 1 to entry: See Figure 6.

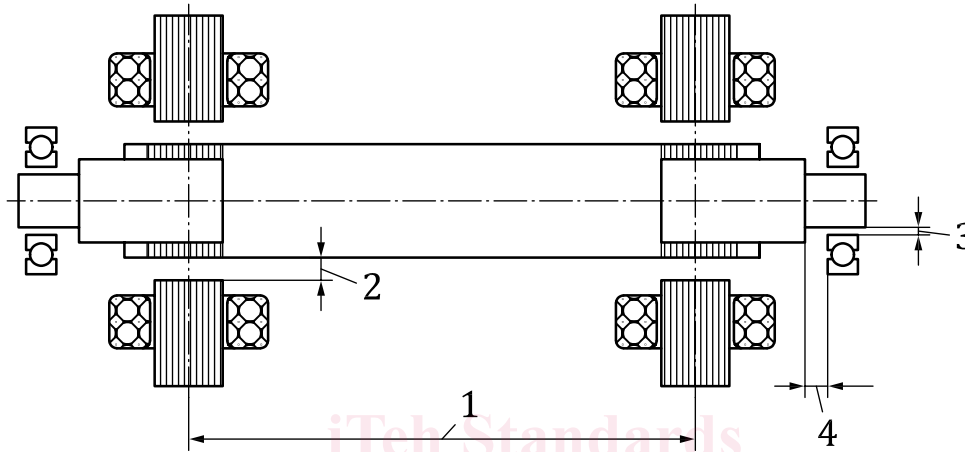

**Key**

- 1 bearing span between radial AMBs
- 2 magnetic radial clearance of radial AMB
- 3 radial clearance of touch-down bearing
- 4 axial clearance of touch-down bearing

iTeh Standards  
(https://standards.itih.ai)  
Document Preview

ISO 14839-1:2018

<https://standards.itih.ai/catalog/standards/iso-14839-1-2018> **Figure 6 — Heteropolar-type radial AMB**

**3.1.20**

**number of poles**

sum of the south and north magnetic gap poles of an AMB (3.1.3)

Note 1 to entry: See Figure 7.

**3.1.21**

**heteropolar-type radial AMB**

radial AMB (3.1.3) in which the electromagnetic cross section has poles of different polarity, and the poles may have different polarity arrangements

Note 1 to entry: Polarity arrangements can be (N, S, N, S, ...), (N, S, S, N, ...), etc.

Note 2 to entry: See Figure 7 a).

**3.1.22**

**homopolar-type radial AMB**

radial AMB (3.1.3) whose electromagnet has more than one axial cross section, each having poles of a single polarity

Note 1 to entry: See Figure 7 b).