



Designation: ~~E1876-07~~ Designation: E 1876 – 09

Standard Test Method for Dynamic Young's Modulus, Shear Modulus, and Poisson's Ratio by Impulse Excitation of Vibration¹

This standard is issued under the fixed designation E 1876; the number immediately following the designation indicates the year of original adoption or, in the case of revision, the year of last revision. A number in parentheses indicates the year of last reapproval. A superscript epsilon (ϵ) indicates an editorial change since the last revision or reapproval.

1. Scope

1.1 This test method covers determination of the dynamic elastic properties of elastic materials at ambient temperatures. Specimens of these materials possess specific mechanical resonant frequencies that are determined by the elastic modulus, mass, and geometry of the test specimen. The dynamic elastic properties of a material can therefore be computed if the geometry, mass, and mechanical resonant frequencies of a suitable (rectangular or cylindrical geometry) test specimen of that material can be measured. Dynamic Young's modulus is determined using the resonant frequency in either the flexural or longitudinal mode of vibration. The dynamic shear modulus, or modulus of rigidity, is found using torsional resonant vibrations. Dynamic Young's modulus and dynamic shear modulus are used to compute Poisson's ratio.

1.2 Although not specifically described herein, this test method can also be performed at cryogenic and high temperatures with suitable equipment modifications and appropriate modifications to the calculations to compensate for thermal expansion.

1.3 There are material specific ASTM standards that cover the determination of resonance frequencies and elastic properties of specific materials by sonic resonance or by impulse excitation of vibration. Test Methods C 215, C 623, ~~C 747~~, ~~C 848~~ C 747, ~~C 848~~ C 848, C 1198, and C 1259 may differ from this test method in several areas (for example; sample size, dimensional tolerances, sample preparation). The testing of these materials shall be done in compliance with these material specific standards. Where possible, the procedures, sample specifications and calculations are consistent with these test methods.

~~1.4 The values stated in SI units are to be regarded as the standard.~~

1.4 The values stated in SI units are to be regarded as standard. No other units of measurement are included in this standard.

1.5 *This standard does not purport to address all of the safety concerns, if any, associated with its use. It is the responsibility of the user of this standard to establish appropriate safety and health practices and determine the applicability of regulatory limitations prior to use.*

2. Referenced Documents

2.1 *ASTM Standards:*²

C 215 [Test Method for Fundamental Transverse, Longitudinal, and Torsional Resonant Frequencies of Concrete Specimens](#)

C 372 [Test Method for Linear Thermal Expansion of Porcelain Enamel and Glaze Frits and Fired Ceramic Whiteware Products by the Dilatometer Method](#)

C 623 [Test Method for Young's Modulus, Shear Modulus, and Poisson's Ratio for Glass and Glass-Ceramics by Resonance](#)

C 747 [Test Method for Moduli of Elasticity and Fundamental Frequencies of Carbon and Graphite Materials by Sonic Resonance](#)

C 848 [Test Method for Young's Modulus, Shear Modulus, and Poisson's Ratio For Ceramic Whitewares by Resonance](#)

C 1161 [Test Method for Flexural Strength of Advanced Ceramics at Ambient Temperature](#)

C 1198 [Test Method for Dynamic Young's Modulus, Shear Modulus, and Poisson's Ratio for Advanced Ceramics by Sonic Resonance](#)

C 1259 [Test Method for Dynamic Young's Modulus, Shear Modulus, and Poisson's Ratio for Advanced Ceramics by Impulse Excitation of Vibration](#)

E 6 [Terminology Relating to Methods of Mechanical Testing](#)

E 177 [Practice for Use of the Terms Precision and Bias in ASTM Test Methods](#)

¹ This test method is under the jurisdiction of ASTM Committee E28 on Mechanical Testing and is the direct responsibility of Subcommittee E28.04 on Uniaxial Testing. Current edition approved ~~June~~ April 1, 2007; ~~2009~~. Published ~~June 2007~~; April 2009. Originally approved in 1997. Last previous edition approved in ~~2006~~ 2007 as ~~E1876-01(2006)~~; E 1876 – 07.

² For referenced ASTM standards, visit the ASTM website, www.astm.org, or contact ASTM Customer Service at service@astm.org. For *Annual Book of ASTM Standards* volume information, refer to the standard's Document Summary page on the ASTM website.

3. Terminology

3.1 *Definitions*—The definitions of terms relating to mechanical testing appearing in Terminology E 6 should be considered as applying to the terms used in this test method.

3.1.1 *dynamic mechanical measurement, n*—a technique in which either the modulus or damping, or both, of a substance under oscillatory applied force or displacement is measured as a function of temperature, frequency, or time, or combination thereof.

3.1.2 *elastic limit* [FL⁻²], *n*—the greatest stress that a material is capable of sustaining without permanent strain remaining upon complete release of the stress. **E 6**

3.1.3 *elastic modulus* [FL⁻²], *n*—the ratio of stress to strain below the proportional limit. **E 6**

3.1.4 *Poisson's ratio* (μ) [nd], *n*—the absolute value of the ratio of transverse strain to the corresponding axial strain resulting from uniformly distributed axial stress below the proportional limit of the material.

3.1.4.1 *Discussion*—In isotropic materials, Young's Modulus (E), shear modulus (G), and Poisson's ratio (μ) are related by the following equation:

$$\mu = (E/2G) - 1 \quad (1)$$

E 6

3.1.5 *proportional limit* [FL⁻²], *n*—the greatest stress that a material is capable of sustaining without deviation from proportionality of stress to strain (Hooke's law). **E 6**

3.1.6 *shear modulus* (G) [FL⁻²], *n*—the elastic modulus in shear or torsion. Also called modulus of rigidity or torsional modulus. **E 6**

3.1.7 *Young's modulus* (E) [FL⁻²], *n*—the elastic modulus in tension or compression. **E 6**

3.2 *Definitions of Terms Specific to This Standard:*

3.2.1 *antinodes, n*—two or more locations that have local maximum displacements, called antinodes, in an unconstrained slender rod or bar in resonance. For the fundamental flexure resonance, the antinodes are located at the two ends and the center of the specimen.

3.2.2 *elastic, adj*—the property of a material such that an application of stress within the elastic limit of that material making up the body being stressed will cause an instantaneous and uniform deformation, which will be eliminated upon removal of the stress, with the body returning instantly to its original size and shape without energy loss. Most elastic materials conform to this definition well enough to make this resonance test valid.

3.2.3 *flexural vibrations, n*—the vibrations that occur when the oscillations in a slender rod or bar are in a plane normal to the length dimension.

3.2.4 *homogeneous, adj*—the condition of a specimen such that the composition and density are uniform, so that any smaller specimen taken from the original is representative of the whole. Practically, as long as the geometrical dimensions of the test specimen are large with respect to the size of individual grains, crystals, components, pores, or microcracks, the body can be considered homogeneous.

3.2.5 *in-plane flexure, n*—for rectangular parallelepiped geometries, a flexure mode in which the direction of displacement is in the major plane of the test specimen.

3.2.6 *isotropic, adj*—the condition of a specimen such that the values of the elastic properties are the same in all directions in the material. Materials are considered isotropic on a macroscopic scale, if they are homogeneous and there is a random distribution and orientation of phases, crystallites, components, pores, or microcracks.

3.2.7 *longitudinal vibrations, n*—the vibrations that occur when the oscillations in a slender rod or bar are parallel to the length of the rod or bar.

3.2.8 *nodes, n*—a slender rod or bar in resonance containing one or more locations having a constant zero displacement. For the fundamental flexural resonance of such a rod or bar, the nodes are located at 0.224 L from each end, where L is the length of the specimen.

3.2.9 *out-of-plane flexure, n*—for rectangular parallelepiped geometries, a flexure mode in which the direction of displacement is perpendicular to the major plane of the test specimen.

3.2.10 *resonant frequency, n*—naturally occurring frequencies of a body driven into flexural, torsional, or longitudinal vibration that are determined by the elastic modulus, mass, and dimensions of the body. The lowest resonant frequency in a given vibrational mode is the fundamental resonant frequency of that mode.

3.2.11 *slender rod or bar, n*—in dynamic elastic property testing, a specimen whose ratio of length to minimum cross-sectional dimension is at least 5 and preferably in the range from 20 to 25.

3.2.12 *torsional vibrations, n*—the vibrations that occur when the oscillations in each cross-sectional plane of a slender rod or bar are such that the plane twists around the length dimension axis.

4. Summary of Test Method

4.1 This test method measures the fundamental resonant frequency of test specimens of suitable geometry by exciting them mechanically by a singular elastic strike with an impulse tool. A transducer (for example, contact accelerometer or non-contacting microphone) senses the resulting mechanical vibrations of the specimen and transforms them into electric signals. Specimen supports, impulse locations, and signal pick-up points are selected to induce and measure specific modes of the transient vibrations.

The signals are analyzed, and the fundamental resonant frequency is isolated and measured by the signal analyzer, which provides a numerical reading that is (or is proportional to) either the frequency or the period of the specimen vibration. The appropriate fundamental resonant frequencies, dimensions, and mass of the specimen are used to calculate dynamic Young's modulus, dynamic shear modulus, and Poisson's ratio.

5. Significance and Use

5.1 This test method may be used for material development, characterization, design data generation, and quality control purposes.

5.2 This test method is specifically appropriate for determining the modulus of materials that are elastic, homogeneous, and isotropic **(1)**.³

5.3 This test method addresses the room temperature determination of dynamic moduli of elasticity of slender bars (rectangular cross section) and rods (cylindrical). Flat plates and disks may also be measured similarly, but the required equations for determining the moduli are not addressed herein.

5.4 This dynamic test method has several advantages and differences from static loading techniques and from resonant techniques requiring continuous excitation.

5.4.1 The test method is nondestructive in nature and can be used for specimens prepared for other tests. The specimens are subjected to minute strains; hence, the moduli are measured at or near the origin of the stress-strain curve, with the minimum possibility of fracture.

5.4.2 The impulse excitation test uses an impact tool and simple supports for the test specimen. There is no requirement for complex support systems that require elaborate setup or alignment.

5.5 This technique can be used to measure resonant frequencies alone for the purposes of quality control and acceptance of test specimens of both regular and complex shapes. A range of acceptable resonant frequencies is determined for a specimen with a particular geometry and mass. The technique is particularly suitable for testing specimens with complex geometries (other than parallelepipeds, cylinders/rods, or disks) that would not be suitable for testing by other procedures. Any specimen with a frequency response falling outside the prescribed frequency range is rejected. The actual modulus of each specimen need not be determined as long as the limits of the selected frequency range are known to include the resonant frequency that the specimen must possess if its geometry and mass are within specified tolerances.

5.6 If a thermal treatment or an environmental exposure affects the elastic response of the test specimen, this test method may be suitable for the determination of specific effects of thermal history, environment exposure, and so forth. Specimen descriptions should include any specific thermal treatments or environmental exposures that the specimens have received.

6. Interferences

6.1 The relationships between resonant frequency and dynamic modulus presented herein are specifically applicable to homogeneous, elastic, isotropic materials.

6.1.1 This method of determining the moduli is applicable to composite and inhomogeneous materials only with careful consideration of the effect of inhomogeneities and anisotropy. The character (volume fraction, size, morphology, distribution, orientation, elastic properties, and interfacial bonding) of the reinforcement and inhomogeneities in the specimens will have a direct effect on the elastic properties of the specimen as a whole. These effects must be considered in interpreting the test results for composites and inhomogeneous materials.

6.1.2 The procedure involves measuring transient elastic vibrations. Materials with very high damping capacity may be difficult to measure with this technique if the vibration damps out before the frequency counter can measure the signal (commonly within three to five cycles).

6.1.3 If specific surface treatments (coatings, machining, grinding, etching, and so forth) change the elastic properties of the near-surface material, there will be accentuated effects on the properties measured by this flexural method, as compared to static/bulk measurements by tensile or compression testing.

6.1.4 This test method is not satisfactory for specimens that have major discontinuities, such as large cracks (internal or surface) or voids.

6.2 This test method for determining moduli is limited to specimens with regular geometries (rectangular parallelepiped, cylinders, and disks) for which analytical equations are available to relate geometry, mass, and modulus to the resonant vibration frequencies. This test method is not appropriate for determining the elastic properties of materials that cannot be fabricated into such geometries.

6.2.1 The analytical equations assume parallel and concentric dimensions for the regular geometries of the specimen. Deviations from the specified tolerances for the dimensions of the specimens will change the resonant frequencies and introduce error into the calculations.

6.2.2 Edge treatments such as chamfers or radii are not considered in the analytical equations. Edge chamfers change the resonant frequency of the test bars and introduce error into the calculations of the dynamic modulus. It is recommended that specimens for this test method not have chamfered or rounded edges.

³ The boldface numbers in parentheses refer to the list of references at the end of this standard.

6.2.3 For specimens with as-fabricated and rough or uneven surfaces, variations in dimension can have a significant effect in the calculations. For example, in the calculation of dynamic modulus, the modulus value is inversely proportional to the cube of the thickness. Uniform specimen dimensions and precise measurements are essential for accurate results.

6.3 This test method assumes that the specimen is vibrating freely, with no significant restraint or impediment. Specimen supports should be designed and located properly in accordance with the instructions so the specimen can vibrate freely in the desired mode. In using direct contact transducers, the transducer should be positioned away from antinodes and with minimal force to avoid interference with free vibration.

6.4 Proper location to the impulse point and transducer is important in introducing and measuring the desired vibration mode. The locations of the impulse point and transducer should not be changed in multiple readings; changes in position may develop and detect alternate vibration modes. In the same manner, the force used in impacting should be consistent in multiple readings.

6.5 If the frequency readings are not repeatable for a specific set of impulse and transducer locations on a specimen, it may be because several different modes of vibration are being developed and detected in the test. The geometry of the test bar and desired vibration mode should be evaluated and used to identify the nodes and antinodes of the desired vibrations. More consistent measurements may be obtained if the impulse point and transducer locations are shifted to induce and measure the single desired mode of vibration.

7. Apparatus

7.1 Apparatus suitable for accurately detecting, analyzing, and measuring the fundamental resonant frequency or period of a vibrating free-free beam is used. The test apparatus is shown in Fig. 1. It consists of an impulser, a suitable pickup transducer to convert the mechanical vibration into an electrical signal, an electronic system (consisting of a signal conditioner/amplifier, a signal analyzer, and a frequency readout device), and a support system. Commercial instrumentation is available that measures the frequency or period of the vibrating specimen.⁴

7.2 *Impulser*—The exciting impulse is imparted by lightly striking the specimen with a suitable implement. This implement should have most of its mass concentrated at the point of impact and have mass sufficient to induce a measurable mechanical vibration, but not so large as to displace or damage the specimen physically. In practice, the size and geometry of the impulser depends on the size and weight of the specimen and the force needed to produce vibration. For commonly tested geometries (small bars, rods, and disks) an example of such an impulser would be a steel sphere 0.5 cm in diameter glued to the end of a flexible 10-cm long polymer rod. (See Fig. 2.) An alternate impulser would be a solid metal, ceramic, or polymer sphere (0.1 to 1.0 cm in diameter) dropped on the specimen through a guide tube to ensure proper impulse position.

7.3 *Signal Pickup*—Signal detection can be by means of transducers in direct contact with the specimen or by noncontact transducers. Contact transducers are commonly accelerometers using piezoelectric or strain gage methods to measure the vibration. Non contact transducers are commonly acoustic microphones, but they may also use laser, magnetic, or capacitance methods to measure the vibration. The frequency range of the transducer shall be sufficient to measure the expected frequencies of the specimens of interest. A suitable range would be from 100 Hz to 50 kHz for most advanced ceramic test specimens. (Smaller and stiffer specimens vibrate at higher frequencies.) The frequency response of the transducer across the frequency range of interest shall have a bandwidth of at least 10 % of the maximum measured frequency before -3 dB power loss occurs.

7.4 *Electronic System*—The electronic system consists of a signal conditioner/amplifier, signal analyzer, and a frequency readout device. The system should have accuracy and precision sufficient to measure the frequencies of interest to an accuracy of 0.1 %. The signal conditioner/amplifier should be suitable to power the transducer and provide an appropriate amplified signal to the signal analyzer. The signal analysis system consists of a frequency counting device and a readout device. Appropriate devices are frequency counter systems with storage capability or digital storage oscilloscopes with a frequency counter module. With the digital storage oscilloscope, a Fast Fourier Transform signal analysis system may be useful for analyzing more complex waveforms and identifying the fundamental resonant frequency.

7.5 *Support System*— The support shall serve to isolate the specimen from extraneous vibration without restricting the desired mode of specimen vibration. Appropriate materials should be stable at the test temperatures. Support materials can be either soft

⁴ Suitable instrumentation is the Grindosonic instrument. The sole source of supply of this instrument is J. W. Lemmens, 3466 Bridgeland Dr., St. Louis, MO 63044-2606. If you are aware of alternative suppliers, please provide this information to ASTM Headquarters. Your comments will receive careful consideration at a meeting of the responsible technical committee, which you may attend.

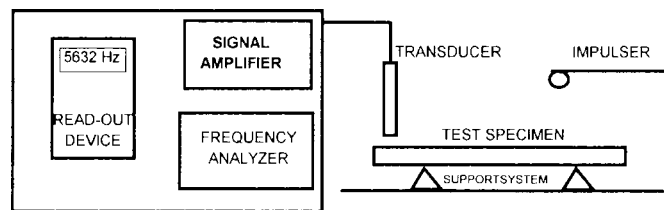

FIG. 1 Block Diagram of Typical Test Apparatus

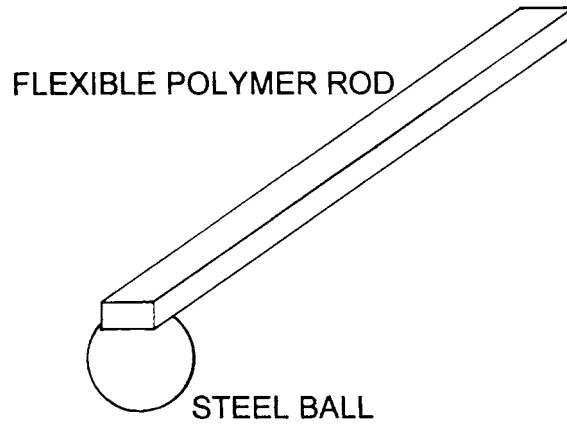

FIG. 2 Diagram of Typical Impulser for Small Specimens

or rigid for ambient conditions. Examples of soft materials would be a compliant elastomeric material, such as polyurethane foam strips. Such foam strips would have simple flat surfaces for the specimen to rest on. Rigid materials, such as metal or ceramic, should have sharp knife edges or cylindrical surfaces on which the specimen should rest. The rigid supports should be resting on isolation pads to prevent ambient vibrations from being picked up by the transducer. Wire suspension can also be used. Specimens shall be supported along node lines appropriate for the desired vibration in the locations described in Section 8.

8. Test Specimen

8.1 The specimens shall be prepared so that they are either rectangular or circular in cross section. Either geometry can be used to measure both dynamic Young’s modulus and dynamic shear modulus. Although the equations for computing shear modulus with a cylindrical specimen are both simpler and more accurate than those used with a rectangular bar, experimental difficulties in obtaining torsional resonant frequencies for a cylindrical specimen usually preclude its use for determining shear modulus.

8.2 Resonant frequencies for a given specimen are functions of the specimen dimensions as well as its mass and moduli; dimensions should therefore be selected with this relationship in mind. The selection of size shall be made so that, for an estimated modulus, the resonant frequencies measured will fall within the range of frequency response of the transducers and electronics used. For a slender rod, the ratio of length to minimum cross-sectional dimension shall have a value of at least 5. However, a ratio of approximately 20 ≈ 25 is preferred for ease in calculation. For shear modulus measurements of rectangular bars, a ratio of width to thickness of 5 or greater is recommended for minimizing experimental difficulties.

8.3 All surfaces on the rectangular specimen shall be flat. Opposite surfaces across the length, thickness, and width shall be parallel to within 0.1 %. The cylindrical specimen shall be round and constant in diameter to within 0.1 %.

8.4 Specimen mass shall be determined to within 0.1 %.

8.5 Specimen length shall be measured to within 0.1 %. The thickness and width of the rectangular specimen shall be measured to within 0.1 % at three locations and an average determined. The diameter of the cylindrical specimen shall be measured to within 0.1 % at three locations and an average determined.

8.6 Table 1 illustrates how uncertainties in the measured parameters influence the calculated modulus. It shows that calculations are most sensitive to error in the measurement of the thickness. Special care must be taken when measuring the thickness of samples with a thickness of less than 3 mm.

9. Procedure

9.1 Activate all electrical equipment, and allow it to stabilize according to the manufacturer’s recommendations.

9.2 Use a test specimen established as a verification/calibration standard to verify the equipment response and accuracy.

9.3 *Fundamental Flexural Resonant Frequency (Out-of-Plane Flexure):*

9.3.1 Place the specimen on the supports located at the fundamental nodal points (0.224 L from each end; see Fig. 3).

9.3.2 Determine the direction of maximum sensitivity for the transducer. Orient the transducer so that it will detect the desired vibration.

TABLE 1 Effects of Variable Error on Modulus Calculation

Variable	Measurement Error	Variable Exponent in Modulus Equation	Calculation Error
Frequency (<i>f</i>)	0.1 %	f^2	0.2 %
Length (<i>L</i>)	0.1 %	L^3	0.3 %
Mass (<i>m</i>)	0.1 %	<i>m</i>	0.1 %
Width (<i>b</i>)	0.1 %	b^{-1}	0.1 %
Thickness (<i>t</i>)	0.1 %	t^{-3}	0.3 %
Diameter (<i>D</i>)	0.1 %	D^{-4}	0.4 %

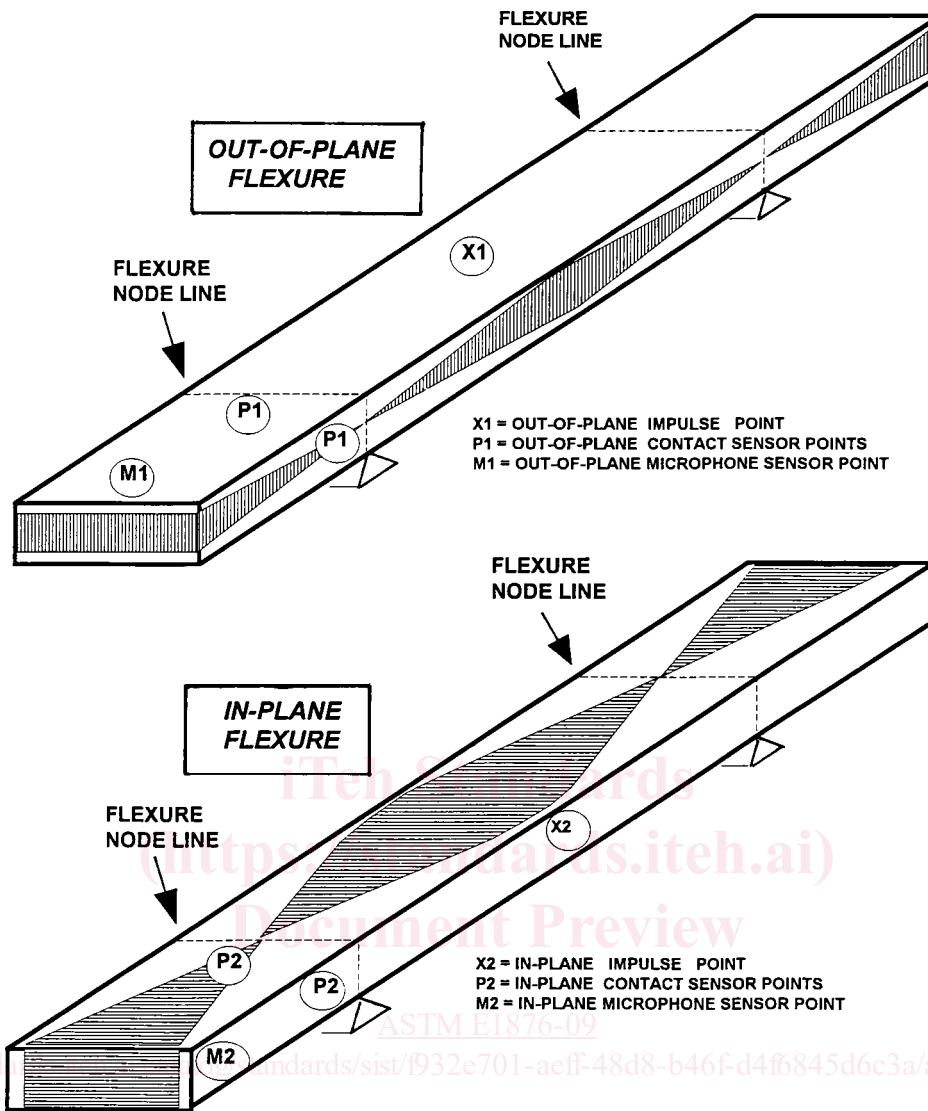

FIG. 3 Rectangular Specimens Tested for In-Plane and Out-of-Plane Flexure

9.3.2.1 *Direct Contact Transducers*—Place the transducer in contact with the test specimen to pick up the desired vibration. If the transducer is placed at an antinode (location of maximum displacement), it may mass load the specimen and modify the natural vibration. The transducer should preferably be placed only as far from the nodal points as necessary to obtain a reading (see Fig. 3). This location will minimize the damping effect from the contacting transducer. The transducer contact force should be consistent, with good response and minimal interference with the free vibration of the specimen.

9.3.2.2 *Non Contact Transducers*—Place the non-contact transducer over an antinode point and close enough to the test specimen to pick up the desired vibration, but not so close as to interfere with the free vibration (see Fig. 3).

9.3.3 Strike the specimen lightly and elastically, either at the center of the specimen or at the opposite end of the specimen from the detecting transducer (see Fig. 3).

9.3.4 Record the resultant reading, and repeat the test until five consecutive readings are obtained that lie within 1 % of each other. Use the average of these five readings to determine the fundamental resonant frequency in flexure.

9.4 *Fundamental Flexural Resonant Frequency (In-Plane Flexure):*

9.4.1 This procedure is the same as 9.3, except that the direction of vibration is in the major plane of the specimen. This measurement can be performed in two ways. In one case, move the transducer and impulser 90° around the long axis of the test specimen to introduce and detect vibrations in the major plane (see Fig. 3). In the alternate method, rotate the test bar 90° around its long axis and reposition it on the specimen supports. Transpose the width and thickness dimensions in the calculations. For homogeneous, isotropic materials, the calculated moduli should be the same as the moduli calculated from the out-of-plane frequency. The comparison of in-plane and out-of-plane frequency measurements can thus be used as a cross check of experimental methods and calculations.

9.5 *Fundamental Torsional Resonant Frequency:*