



# Standard Specification for Cold Expansion Fittings with PEX Reinforcing Rings for Use with Cross-linked Polyethylene (PEX) Tubing<sup>1</sup>

This standard is issued under the fixed designation F1960; the number immediately following the designation indicates the year of original adoption or, in the case of revision, the year of last revision. A number in parentheses indicates the year of last reapproval. A superscript epsilon ( $\epsilon$ ) indicates an editorial change since the last revision or reapproval.

## 1. Scope\*

1.1 This specification covers cold expansion fittings and cross-linked (PEX) reinforcing rings for use with cross-linked polyethylene (PEX) plastic tubing in  $\frac{3}{8}$ ,  $\frac{1}{2}$ ,  $\frac{5}{8}$ ,  $\frac{3}{4}$ , 1, 1- $\frac{1}{4}$ , 1 $\frac{1}{2}$  in. and 2 in. nominal diameters that meet the requirements of Specifications F876 and F877. These fittings are intended for use in 100 psi (690 kPa) cold- and hot-water distribution systems operating at temperatures up to and including 180°F (82°C). The system is comprised of a PEX reinforcing ring and a cold expansion fitting. Included are the requirements for materials, workmanship, dimensions, and markings to be used on the fitting components. The components covered by this specification are intended for use in residential and commercial, hot and cold, potable water distribution systems as well as sealed central heating, including under-floor-heating systems.

1.2 The values stated in inch-pound units are to be regarded as the standard. The values given in parentheses are mathematical conversions to SI units which are provided for information only and are not considered standard.

1.3 *This standard does not purport to address all of the safety concerns, if any, associated with its use. It is the responsibility of the user of this standard to establish appropriate safety and health practices and determine the applicability of regulatory limitations prior to use.*

## 2. Referenced Documents

### 2.1 ASTM Standards:<sup>2</sup>

- A351/A351M Specification for Castings, Austenitic, for Pressure-Containing Parts
- B16/B16M Specification for Free-Cutting Brass Rod, Bar and Shapes for Use in Screw Machines
- B140/B140M Specification for Copper-Zinc-Lead (Red Brass or Hardware Bronze) Rod, Bar, and Shapes

- B62 Specification for Composition Bronze or Ounce Metal Castings
  - B75 Specification for Seamless Copper Tube
  - B283 Specification for Copper and Copper-Alloy Die Forgings (Hot-Pressed)
  - B371/B371M Specification for Copper-Zinc-Silicon Alloy Rod
  - B584 Specification for Copper Alloy Sand Castings for General Applications
  - D792 Test Methods for Density and Specific Gravity (Relative Density) of Plastics by Displacement
  - D1505 Test Method for Density of Plastics by the Density-Gradient Technique
  - D1600 Terminology for Abbreviated Terms Relating to Plastics
  - D2122 Test Method for Determining Dimensions of Thermoplastic Pipe and Fittings
  - D2765 Test Methods for Determination of Gel Content and Swell Ratio of Crosslinked Ethylene Plastics
  - D3035 Specification for Polyethylene (PE) Plastic Pipe (DR-PR) Based on Controlled Outside Diameter
  - D6394 Specification for Sulfone Plastics (SP)
  - F412 Terminology Relating to Plastic Piping Systems
  - F876 Specification for Crosslinked Polyethylene (PEX) Tubing
  - F877 Specification for Crosslinked Polyethylene (PEX) Plastic Hot- and Cold-Water Distribution Systems
- ### 2.2 ANSI Standard:
- B1.20 Pipe Threads General Purpose<sup>3</sup>
  - B16.18 Cast Copper Alloy Solder Joint Pressure Fittings
  - B16.22 Wrought Copper and Copper Alloy Solder Joint Pressure Fittings
- ### 2.3 NSF Standards:
- NSF 14 for Plastic Piping Components and Related Materials<sup>4</sup>
  - NSF 61 for Drinking Water System Components-Health Effects<sup>4</sup>

<sup>1</sup> This specification is under the jurisdiction of ASTM Committee F17 on Plastic Piping Systems and is the direct responsibility of Subcommittee F17.10 on Fittings. Current edition approved April 1, 2009. Published April 2009. Originally approved in 1999. Last previous edition approved in 2008 as F1960 – 08. DOI: 10.1520/F1960-09.

<sup>2</sup> For referenced ASTM standards, visit the ASTM website, www.astm.org, or contact ASTM Customer Service at service@astm.org. For *Annual Book of ASTM Standards* volume information, refer to the standard's Document Summary page on the ASTM website.

<sup>3</sup> Available from American National Standards Institute (ANSI), 25 W. 43rd St., 4th Floor, New York, NY 10036, http://www.ansi.org

<sup>4</sup> Available from NSF International, P.O. Box 130140, 789 N. Dixboro Rd., Ann Arbor, MI 48113-0140, http://www.nsf.org.

\*A Summary of Changes section appears at the end of this standard.

2.4 *Manufacturers' Standardization Society Standards: SP-104* Wrought Copper Solder Joint Pressure Fittings<sup>5</sup>

### 3. Terminology

3.1 *Definitions*—Definitions are in accordance with Terminology **F412** and abbreviations are in accordance with Terminology **D1600**, unless otherwise indicated.

3.1.1 *PEX reinforcing rings*—cross-linked polyethylene rings used to add contraction force around the cold expansion fittings.

### 4. Classification

4.1 This specification covers one class of cold expansion fittings with PEX reinforcing rings suitable for use with PEX tubing that meets the requirements of Specifications **F876** and **F877**.

### 5. Materials and Manufacture

5.1 Cold expansion fittings shall be made from one of the following materials:

#### 5.1.1 Brass:

5.1.1.1 *Machined Brass*—Machined brass fittings shall be made from material meeting the requirements of Specification **B140/B140M** copper alloy UNS No. C31400, or Specification **B16/B16M** copper alloy UNS No. C36000, or Specification **B371/B371M** copper alloy UNS No. C69300, or Standard EN 12164, copper alloy CW614N, or copper alloy UNS No. C35330.

5.1.1.2 *Forged Brass*—Forged brass fittings shall be made from material meeting the requirements of Specification **B283**, copper alloy UNS Nos. C37700, C36500, or C69300.

5.1.1.3 *Cast Copper Alloys*—Cast copper alloy fittings shall be made from material meeting the requirements of Specification **B584**, copper alloy UNS Nos. C84400, C83800, C87850 or C89844 or C89836 or Specification **B62**, copper alloy UNS No. C83600, or Standard EN 1982, copper alloy EN Symbol CuSn4Zn6Pb3–C.

#### 5.1.2 Sulfone:

5.1.2.1 *20 % Glass-Filled Polysulfone*—Polysulfone fittings produced using glass reinforcement shall be molded from polysulfone materials as specified in Specification **D6394**. The polymers shall consist of polysulfone and glass fiber and meet the following line call out for additional properties (SP0113G20A30430).

5.1.2.2 *Unreinforced Sulfone Plastic (SP)*—Fittings shall be molded from sulfone plastic (SP) as specified in Specification **D6394**. The material shall be unreinforced polysulfone (group 01, class 1, grade 2), or polyphenylsulfone (group 3, class 1, grade 2.) Material may also be an unreinforced blend of these two materials with the polyphenylsulfone continuous phase comprising 55 to 80% of the blend.

5.1.2.3 Clean rework material of the same commercial designation, generated for the manufacturer's own production may be used by the same manufacturer, provided the fittings

meet all of the requirements of this specification. Rework material shall not be introduced at a ratio exceeding 25%.

5.2 Reinforcing rings shall be made from PEX material meeting the performance requirements of **6.1**.

5.3 *Stainless Steel*—fittings shall be made from material meeting the requirements of Specification **A351/A351M**, stainless steel UNS No. J92800.

5.4 *Wrought Copper*—Wrought copper fittings shall be made from material meeting the requirements of Specification **B75** for one of the following coppers: copper UNS C10200, C10300, C10800, or C12200.

### 6. General Requirements

6.1 The following sections of Specification **F877** constitute a part of this specification.

6.1.1 Requirements,

6.1.2 Test Methods, and

6.1.3 Retest and Rejection.

6.2 In addition, when a section with a title identical to that referenced in **6.1**, above, appears in this specification, it contains additional requirements that supplement those appearing in **F877**.

6.3 *System Performance Requirements:*

6.3.1 *General*—All performance tests shall be performed on assemblies of fittings, PEX reinforcing rings and PEX tubing. Fittings and reinforcing rings shall meet the material and dimensional requirements of this specification. PEX tubing shall meet the requirements of Specifications **F876** and **F877**. Assembly of test specimens shall be in accordance with **10.1**. Each assembly shall contain at least two joints. Use separate sets of assemblies for each performance test requirement.

6.3.2 *Dimensions*—Any randomly selected fitting or fittings and PEX reinforcing rings shall be used to determine dimensions. Measurements shall be made in accordance with Test Method **D2122**, except determine diameter by making measurements at four locations spaced at approximately 45° apart around the circumference. Inspection and gauging of solder joint ends shall be accordance with ANSI **B16.18**, ANSI **B16.22**, or Manufacturers' Standardization Society **SP-104**.

### 7. Performance Requirements

7.1 *PEX Reinforcing Rings:*

7.1.1 *Density*—When determined in accordance with **11.1**, the PEX reinforcing rings shall have a density in the range from 926 to 940 kg/m<sup>3</sup>.

7.1.2 *Degree of Cross-linking*—When tested in accordance with **11.2**, the degree of cross-linking for PEX reinforcing rings shall be within the range from 70 to 89% inclusive.

7.1.3 *Stabilizer Migration Resistance*—When tested in accordance with **11.3**, the time  $t^2$ , shall be at least 50% of the time,  $t^1$ .

### 8. Dimensions

8.1 *Dimensions and Tolerances*—The dimensions and tolerances of fittings and PEX reinforcing rings shall be as shown in **Figs. 1 and 2** and **Fig. 4** when measured in accordance with **6.3.2**.

8.1.1 *Alignment*—The maximum angular variation of any opening shall not exceed 1° off the true centerline axis.

<sup>5</sup> Available from Manufacturers Standardization Society of the Valve and Fittings Industry (MSS), 127 Park St., NE, Vienna, VA 22180-4602, <http://www.mss-hq.com>.

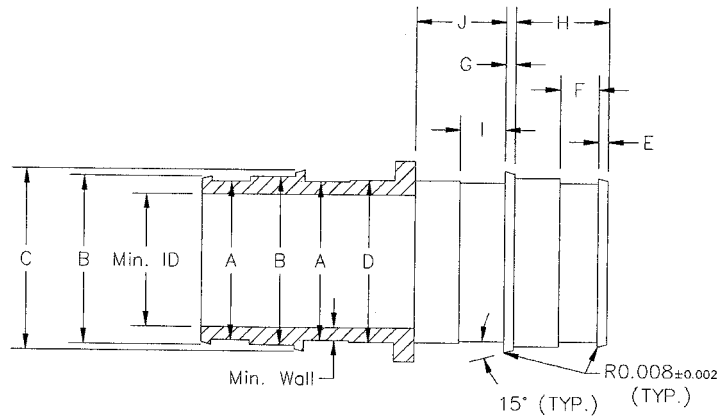

NOTES: BREAK ALL INTERNAL CORNERS 0.010 – 0.015  
ALL DIAMETER CONCENTRICITY 0.005 TIR

Brass, Stainless Steel and Wrought Copper Dimensions

Size	Min. Wall	Min. ID	A	B	C	D	E	F	G	H	I	J
3/8 in.	0.047	0.260	0.375	0.433	0.472	0.407	0.051	0.108	0.051	0.305	0.107	0.266
			0.395	0.441	0.480	0.427	0.067	0.128	0.067	0.325	0.127	0.286
1/2 in.	0.057	0.378	0.513	0.571	0.610	0.545	0.051	0.108	0.051	0.384	0.147	0.305
			0.533	0.579	0.618	0.565	0.067	0.128	0.067	0.404	0.167	0.325
5/8 in.	0.057	0.500	0.635	0.689	0.740	0.663	0.051	0.147	0.051	0.462	0.187	0.384
			0.655	0.697	0.748	0.683	0.067	0.167	0.067	0.482	0.207	0.404
3/4 in.	0.057	0.595	0.728	0.787	0.866	0.762	0.051	0.187	0.051	0.502	0.226	0.423
			0.748	0.795	0.874	0.782	0.067	0.207	0.067	0.522	0.246	0.443
1 in.	0.072	0.795	0.965	1.024	1.102	0.978	0.051	0.226	0.051	0.620	0.265	0.541
			0.985	1.032	1.110	0.998	0.067	0.246	0.067	0.640	0.285	0.561
1-1/4 in.	0.075	0.960	1.139	1.266	1.352	1.217	0.064	0.279	0.064	0.761	0.328	0.664
			1.159	1.276	1.362	1.237	0.080	0.299	0.080	0.781	0.348	0.684
1-1/2 in.	0.095	1.084	1.304	1.374	1.486	1.329	0.077	0.331	0.077	0.899	0.388	0.785
			1.324	1.382	1.494	1.349	0.093	0.351	0.093	0.919	0.408	0.805
2 in.	0.095	1.550	1.790	1.954	2.075	0.881	0.085	0.457	0.085	1.204	0.511	1.020
			1.800	1.958	2.079	0.891	0.093	0.467	0.093	1.184	0.521	1.030

ASTM F1960-09

FIG. 1 Brass and Stainless Steel and Wrought Copper Insert Dimensions and Tolerances

8.1.2 *Fittings with Solder Joint Ends*—Solder joint ends shall be in accordance with ANSI B16.22, ANSI B16.18 or MSS SP-104.

8.1.3 *Tapered Threaded Ends*—Fitting threads shall be right-hand conforming to ANSI B1.20.1. They shall be taper threads (NPT).

## 9. Workmanship, Finish and Appearance

9.1 The fittings shall be made from compounds that are homogeneous throughout. The sealing surfaces of the insert shall be smooth and free of foreign material. The fitting walls shall be free of cracks, holes, blisters, voids, foreign inclusions, or other defects that are visible to the naked eye and that affect wall integrity.

## 10. Assembly

10.1 *Cold Expansion Joints*—Fittings shall be joined to PEX tubing by the contraction of the tubing and reinforcing ring over the insert of the cold expansion fitting. Fittings and PEX reinforcing rings shall meet the dimensional and material

requirements of this standard. PEX tubing shall meet the requirements of Specification F876 or F877.

10.2 *Expansion Tool*—The expansion tool shall expand the PEX tubing and reinforcing ring to a maximum inside diameter as listed in Table 1. The expanded tubing shall be round to ensure uniform contraction of the tubing around the cold expansion fitting. The expansion tool shall be inspected for wear according to the manufacturer’s instructions.

### 10.3 Procedure:

10.3.1 *Assembly of Connections*—Affix the cold expansion fitting to the PEX tubing by sliding the PEX reinforcing ring onto the tubing and positioning the ring so that the end of the ring overhangs the end of the tubing a maximum of 1/16 in. (1.6 mm). Insert the expansion head into the tubing as far as it will go. Holding the tool so that the centerline of the expansion head is approximately in line with the centerline of the tubing, operate the tool until the tubing and reinforcing ring are fully expanded. After completing the expansion process, remove the expansion tool and insert the cold expansion fitting until the