



Standard Test Method for Determination of the Point Load Strength Index of Rock¹

This standard is issued under the fixed designation D 5731; the number immediately following the designation indicates the year of original adoption or, in the case of revision, the year of last revision. A number in parentheses indicates the year of last reapproval. A superscript epsilon (ϵ) indicates an editorial change since the last revision or reapproval.

1. Scope

1.1 This test method covers the guidelines, requirements, and procedures for determining the point load strength index of rock. Specimens in the form of rock cores, blocks, or irregular lumps can be tested by this test method. This test method can be performed in the field or laboratory because the testing machine is portable. This is an index test and is intended to be used to classify and characterize rock.

1.2 This test method applies to hard rock (compressive strength over 15 MPa (2200 psi)).

1.3 The values stated in the SI units are to be regarded as standard.

1.4 *This standard does not purport to address all of the safety concerns, if any, associated with its use. It is the responsibility of the user of this standard to establish appropriate safety and health practices and determine the applicability of regulatory limitations prior to use.*

2. Referenced Documents

2.1 ASTM Standards:

D 653 Terminology Relating to Soil, Rock, and Contained Fluids²

D 2216 Test Method for Laboratory Determination of Water (Moisture) Content of Soil and Rock²

D 2938 Test Method for Unconfined Compressive Strength of Intact Rock Core Specimens²

3. Terminology

3.1 Definitions of Terms Specific to This Standard:

3.1.1 *point load strength index*—an indicator of strength (see 9.1) obtained by subjecting a rock specimen to an increasingly concentrated point load, applied through a pair of truncated, conical platens, until failure occurs.³

4. Summary of Test Method

4.1 This index test is performed by subjecting a rock specimen to an increasingly concentrated load until failure

occurs by splitting the specimen. The concentrated load is applied through coaxial, truncated conical platens. The failure load is used to calculate the point load strength index and to estimate the uniaxial compressive strength.

5. Significance and Use

5.1 The uniaxial compression test (see Test Method D 2938) is used to determine compressive strength of rock specimens, but it is a time-consuming and expensive test that requires specimen preparation. When extensive testing is required for preliminary and reconnaissance information, alternative tests such as the point load test can be used in the field to reduce the time and cost of compressive strength tests.

5.2 The point load strength test is used as an index test for strength classification of rock materials. The test results should not be used for design or analytical purposes.

5.3 This test method is performed to determine the point load strength index ($I_s(50)$) of rock specimens, and the point load strength anisotropy index ($I_a(50)$) that is the ratio of point load strengths on different axes that result in the greatest and least values.

5.4 Rock specimens in the form of either core (the diametral and axial tests), cut blocks (the block test), or irregular lumps (the irregular lump test) are tested by application of concentrated load through a pair of truncated, conical platens. Little or no specimen preparation is required.

6. Apparatus

6.1 *General*—A point load tester (see Fig. 1) consists of a loading system typically comprised of a loading frame, platens, a measuring system for indicating load, P , (required to break the specimen), and a means for measuring the distance, D , between the two platen contact points. The equipment shall be resistant to shock and vibration so that the accuracy of readings is not adversely affected by repeated testing.

6.2 Loading System:

6.2.1 The loading system shall have a loading frame with a platen-to-platen clearance that allows testing of rock specimens in the required size range. Typically, this range is within 30 to 85 mm so that an adjustable distance is available to accommodate both small and large specimens.

6.2.2 The loading capacity shall be sufficient to break the largest and strongest specimens to be tested.

6.2.3 The test machine shall be designed and constructed so

¹ This test method is under the jurisdiction of ASTM Committee D-18 on Soil and Rock and is the direct responsibility of Subcommittee D18.12 on Rock Mechanics.

Current edition approved May 15, 1995. Published July 1995.

² *Annual Book of ASTM Standards*, Vol 04.08.

³ "Suggested Methods for Determining Point Load Strength", International Society for Rock Mechanics Commission on Testing Methods, *Int. J. Rock. Mech. Min. Sci. and Geomechanical Abstr.*, Vol 22, No. 2, 1985, pp. 51–60.

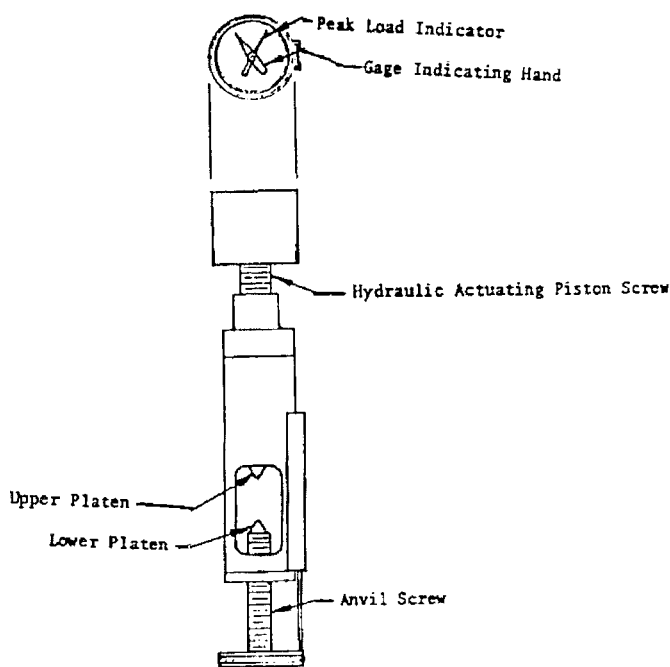

FIG. 1 An Example of a Loading System (The Point Load Strength Index Test)

that it does not permanently distort during repeated applications of the maximum test load, and so that the platens remain coaxial within ± 0.2 mm throughout testing. No spherical seat or other nonrigid component is permitted in the loading system. Loading system rigidity is essential to avoid slippage when specimens of irregular geometry are tested.

6.2.4 Truncated, conical platens, as shown on Fig. 2, are to be used. The 60° cone and 5-mm radius spherical platen tip shall meet tangentially. The platens shall be of hard material (Rockwell 58 HRC) such as tungsten carbide or hardened steel so they remain undamaged during testing.

6.3 Load Measuring System:

6.3.1 A load measuring system, for example a load cell or a hydraulic pressure gage, that will indicate failure load, P , required to break specimen. The system should conform to the requirements of 6.3.2-6.3.4.

6.3.2 Measurements of failure load, P , shall be to a precision of $\pm 5\%$ or better of full-scale load-measuring system, irrespective of the size and strength of specimen that is tested.

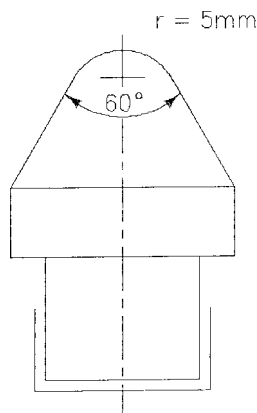

FIG. 2 Platen Dimensions (Point Load Strength Index Test)

6.3.3 Failure is often sudden and a peak load indicator is required so the failure load can be recorded after each test.

6.3.4 The system should be capable of using interchangeable measuring devices in order to be consistent with the estimated strength of rock (point load strength of rock is usually an order of magnitude lower than the compressive strength of rock).

6.4 Distance Measuring System:

6.4.1 The distance measuring system, a vernier direct reading scale, should connect to the loading frame for measuring the distance, D , between specimen-platen contact points and conform to requirements 6.4.2 and 6.4.3.

6.4.2 Measurements of D shall be to an accuracy of $\pm 2\%$ or better of distance between contact points, irrespective of the size and strength of specimen that is tested.

6.4.3 The measuring system shall allow a check of the "zero displacement" value when the two platens are in contact and should include a zero adjustment.

6.4.4 An instrument such as a caliper or a steel rule is required to measure the width, W , (with an accuracy of $\pm 5\%$) of specimens for all but the diametral test.

6.5 Miscellaneous Items—Diamond saw, chisels, towels, marking pens, and plotting paper.

7. Test Specimens

7.1 Sampling—Rock samples are grouped on the basis of both rock type and estimated strength. When testing core or block specimens at least ten specimens are selected. When testing irregular-shaped specimens obtained by other means at least 20 specimens are selected. Specimens in the form of core are preferred for a more precise classification.

7.2 Dimensions—The specimen's external dimensions shall not be less than 30 mm and not more than 85 mm with the preferred dimension about 50 mm.

7.3 Size and Shape—The size and shape requirements for diametral, axial, block, or irregular lump testing shall conform with the recommendations shown on Fig. 3. The sides of the specimens shall be free from abrupt irregularities that can generate stress concentrations. No specimen preparation is required.

7.4 Water Content—Using Test Method D 2216, determine the water content of each specimen after testing since it can affect the value of the point load strength.

7.5 Marking and Measuring Specimens—The specimens shall be properly marked and measured.

7.5.1 Marking—The desired test orientation of the specimen shall be indicated by marking lines on the specimen. These lines are used for centering the specimen in the testing machine, and to ensure proper orientation during testing. These lines may also be used as reference lines for measuring thickness and diameter.

7.5.2 Measuring—Measure each dimension of a specimen at three different places, and calculate the averages.

8. Procedure

8.1 Diametral Test:

8.1.1 Core specimens with length/diameter ratio greater than one are suitable for diametral testing.

8.1.2 Insert a specimen in the test device and close the

ASTM D 5731

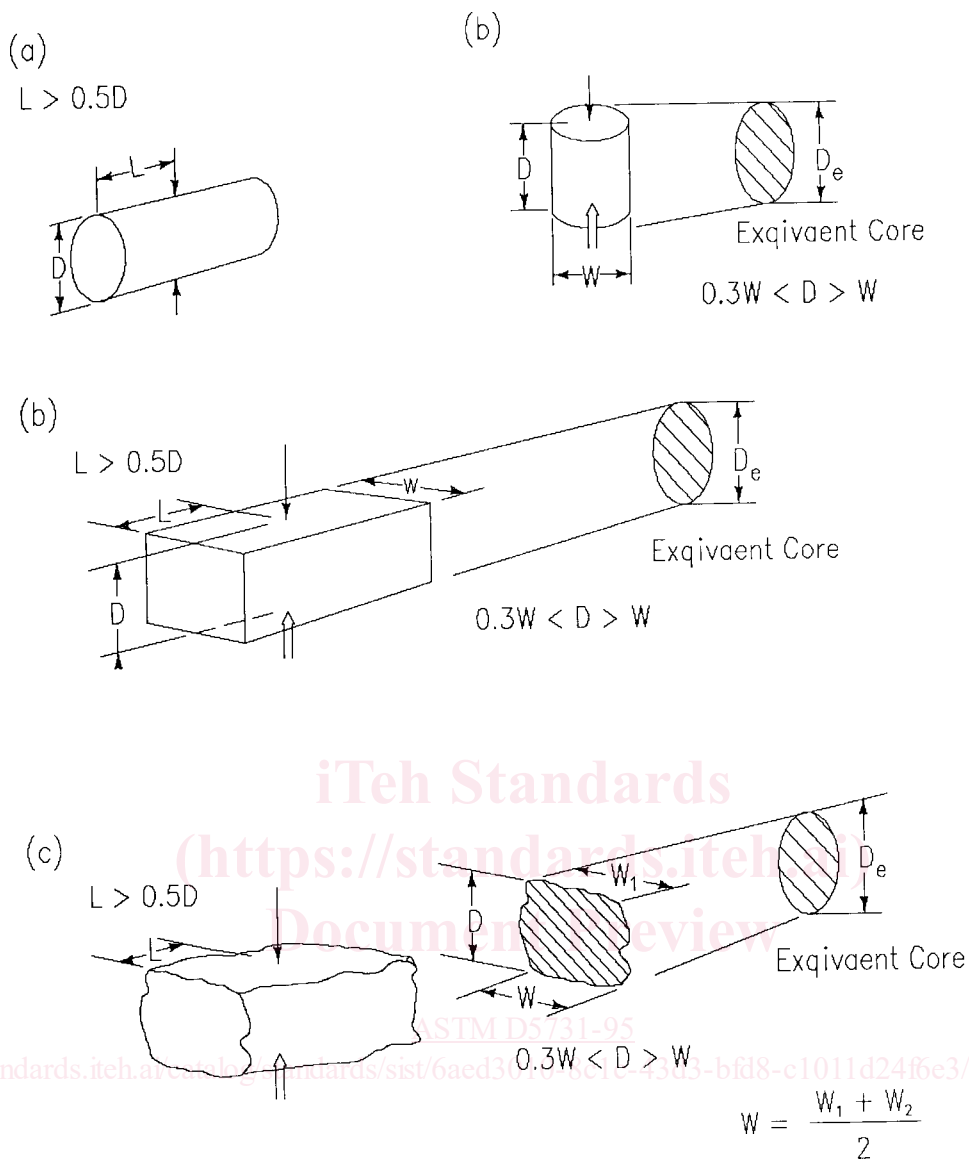

NOTE 1—Legend: L = length, W = width, D = depth or diameter, and D_e = equivalent core diameter (see 9.1).

FIG. 3 Load Configurations and Specimen Shape Requirement for (a) the Diametral Test, (b) the Axial Test, (c) the Block Test, and (d) the Irregular Lump Test

platens to make contact along a core diameter. Ensure that the distance, L , between the contact points and the nearest free end is at least 0.5 times the core diameter (see Fig. 3(a)).

8.1.3 Determine and record the distances D and L (see Fig. 3).

8.1.4 Steadily increase the load such that failure occurs within 10 to 60 s, and record failure load, P . The test should be rejected if the fracture surface passes through only one platen loading point (see Fig. 4(d)).

8.1.5 The procedures in 8.1.2-8.1.4 are repeated for each specimen of the rock type.

8.2 Axial Test:

8.2.1 Core specimens with length/diameter ratio of $\frac{1}{3}$ to 1 are suitable for axial testing (see Fig. 3(b)). Suitable specimens can be obtained by saw-cutting or chisel-splitting.

8.2.2 Insert a specimen in the test machine and close the platens to make contact along a line perpendicular to the core

end faces (in the case of isotropic rock, the core axis, but see 8.4 for anisotropic rock).

8.2.3 Record the distance, D , between platen contact points (see Fig. 3). Record the specimen width, W , perpendicular to the loading direction, with an accuracy of $\pm 5\%$.

8.2.4 Steadily increase the load such that failure occurs within 10 to 60 s, and record the failure load, P . The test should be rejected if the fracture surface passes through only one loading point (see Fig. 4(e)).

8.2.5 Procedures 8.2.2-8.2.4 are repeated for each test specimen of the rock type.

8.3 Block and Irregular Lump Tests:

8.3.1 Rock blocks or lumps, 30 to 85 mm, and of the shape shown in Fig. 3(c) and (d) are suitable for the block and the irregular lump tests. The ratio, D/W , should be between $\frac{1}{3}$ and 1, preferably close to 1. The distance L should be at least 0.5 W .