



SLOVENSKI STANDARD SIST EN 6049-004:2019

01-november-2019

Aeronavtika - Električni kabli, namestitvev - Zaščitna obojka iz metaaramidnih vlaken - 004. del: Opletena, cevasta, dobro raztegljiva - Standard za proizvod

Aerospace series - Electrical cables, installation - Protection sleeve in meta-aramid fibres - Part 004: Braided, tubular, high expandable - Product standard

Luft- und Raumfahrt - Elektrische leitungen, installation - Schutzschlauch aus meta-aramidfasern - Teil 004: Geflecht, röhrenförmig, hoch dehnbar - Produkt norm

Série aérospatiale - Câbles électriques, installation - Gaine de protection en fibres méta-aramides - Partie 004 : Tresse, tubulaire, très expansible - Norme de produit

<https://standards.iteh.ai/catalog/standards/sist/2a04364a-13ab-4600-9a5b-94181a96f78f/sist-en-6049-004-2019>

Ta slovenski standard je istoveten z: EN 6049-004:2019

ICS:

29.060.20	Kabli	Cables
49.060	Letalska in vesoljska električna oprema in sistemi	Aerospace electric equipment and systems

SIST EN 6049-004:2019

en,fr,de

iTeh STANDARD PREVIEW
(standards.iteh.ai)

SIST EN 6049-004:2019

<https://standards.iteh.ai/catalog/standards/sist/2a04364a-13ab-4600-9a5b-94481a96f78f/sist-en-6049-004-2019>

EUROPEAN STANDARD

EN 6049-004

NORME EUROPÉENNE

EUROPÄISCHE NORM

September 2019

ICS 49.060

English Version

**Aerospace series - Electrical cables, installation -
Protection sleeve in meta-aramid fibres - Part 004:
Braided, tubular, high expandable - Product standard**

Série aérospatiale - Câbles électriques, installation -
Gaine de protection en fibres méta-aramides - Partie
004 : Tresse, tubulaire, très expansible - Norme de
produit

Luft- und Raumfahrt - Elektrische leitungen,
installation - Schutzschlauch aus meta-aramidfasern -
Teil 004: Geflecht, röhrenförmig, hoch dehnbar -
Produkt norm

This European Standard was approved by CEN on 18 February 2019.

CEN members are bound to comply with the CEN/CENELEC Internal Regulations which stipulate the conditions for giving this European Standard the status of a national standard without any alteration. Up-to-date lists and bibliographical references concerning such national standards may be obtained on application to the CEN-CENELEC Management Centre or to any CEN member.

This European Standard exists in three official versions (English, French, German). A version in any other language made by translation under the responsibility of a CEN member into its own language and notified to the CEN-CENELEC Management Centre has the same status as the official versions.

CEN members are the national standards bodies of Austria, Belgium, Bulgaria, Croatia, Cyprus, Czech Republic, Denmark, Estonia, Finland, France, Germany, Greece, Hungary, Iceland, Ireland, Italy, Latvia, Lithuania, Luxembourg, Malta, Netherlands, Norway, Poland, Portugal, Republic of North Macedonia, Romania, Serbia, Slovakia, Slovenia, Spain, Sweden, Switzerland, Turkey and United Kingdom.



EUROPEAN COMMITTEE FOR STANDARDIZATION
COMITÉ EUROPÉEN DE NORMALISATION
EUROPÄISCHES KOMITEE FÜR NORMUNG

CEN-CENELEC Management Centre: Rue de la Science 23, B-1040 Brussels

Contents		Page
European foreword		3
1	Scope.....	4
2	Normative references.....	4
3	Terms and definitions	4
4	Required characteristics	4
5	Test methods	6
6	Designation	7
7	Marking.....	7

iTeh STANDARD PREVIEW
(standards.iteh.ai)

[SIST EN 6049-004:2019](https://standards.iteh.ai/catalog/standards/sist/2a04364a-13ab-4600-9a5b-94481a96f78f/sist-en-6049-004-2019)

<https://standards.iteh.ai/catalog/standards/sist/2a04364a-13ab-4600-9a5b-94481a96f78f/sist-en-6049-004-2019>

European foreword

This document (EN 6049-004:2019) has been prepared by the Aerospace and Defence Industries Association of Europe - Standardization (ASD-STAN).

After enquiries and votes carried out in accordance with the rules of this Association, this Standard has received the approval of the National Associations and the Official Services of the member countries of ASD, prior to its presentation to CEN.

This European Standard shall be given the status of a national standard, either by publication of an identical text or by endorsement, at the latest by March 2020, and conflicting national standards shall be withdrawn at the latest by March 2020.

Attention is drawn to the possibility that some of the elements of this document may be the subject of patent rights. CEN shall not be held responsible for identifying any or all such patent rights.

According to the CEN-CENELEC Internal Regulations, the national standards organisations of the following countries are bound to implement this European Standard: Austria, Belgium, Bulgaria, Croatia, Cyprus, Czech Republic, Denmark, Estonia, Finland, France, Germany, Greece, Hungary, Iceland, Ireland, Italy, Latvia, Lithuania, Luxembourg, Malta, Netherlands, Norway, Poland, Portugal, Republic of North Macedonia, Romania, Serbia, Slovakia, Slovenia, Spain, Sweden, Switzerland, Turkey and the United Kingdom.

iTeh STANDARD PREVIEW (standards.iteh.ai)

[SIST EN 6049-004:2019](https://standards.iteh.ai/catalog/standards/sist/2a04364a-13ab-4600-9a5b-94481a96f78f/sist-en-6049-004-2019)

<https://standards.iteh.ai/catalog/standards/sist/2a04364a-13ab-4600-9a5b-94481a96f78f/sist-en-6049-004-2019>

EN 6049-004:2019 (E)**1 Scope**

This document defines the characteristics of high expandable braided tubular mechanical protection sleeves for electrical cable and cable bundles made from meta-aramid fibres and provided with a water repelled protection.

2 Normative references

The following documents are referred to in the text in such a way that some or all of their content constitutes requirements of this document. For dated references, only the edition cited applies. For undated references, the latest edition of the referenced document (including any amendments) applies.

EN 3475-601, *Aerospace series — Cables, electrical, aircraft use — Test methods — Part 601: Smoke density*

EN 3475-602, *Aerospace series — Cables, electrical, aircraft use — Test methods — Part 602: Toxicity*

EN 6049-001, *Aerospace series — Electrical cables, installation — Protection sleeve in meta-aramid fibres Part 001: Technical specification*

EN 6059-100 (all parts), *Aerospace series — Electrical cables, installation — Protection sleeves — Test methods — Part 100: General*

3 Terms and definitions

For the purposes of this document, the terms and definitions given in EN 6049-001.

ISO and IEC maintain terminological databases for use in standardization at the following addresses:

- IEC Electropedia: available at <http://www.electropedia.org/>
- ISO Online browsing platform: available at <http://www.iso.org/obp>

4 Required characteristics**4.1 Composition, dimensions and mass****4.1.1 Composition of the tows**

Each tow shall be built-up of several groups of multifilament fibres made from meta-aramid.

The number of groups which forms a tow and the width of the tow depends on the braiding configuration (braiding figure and braiding angle) of the sleeve, see 4.1.2. The thickness of the tow shall be so that the finished sleeve meet the mechanical and environmental requirements. One length of sleeve shall be built-up of one type of tow.

4.1.2 Composition, dimensions and mass of the sleeve

The composition of the sleeve (braiding figure, braiding angle and tow width) shall be so that the sleeve meet the requirements for dimensions, coverage, expansion range and mass. The coverage shall be 75 % minimum. The braiding figure shall consist of two groups of tows in two directions. The braiding angle between the two groups shall be equal over the length of the sleeve. The maximum difference in length

of a sleeve, measured in the delivered condition and measured on a mandrel with the delivered diameter in accordance with EN 6059-202, is $\pm 3\%$.

Figure 1 and Table 1 give the composition and the dimensions of the sleeve.

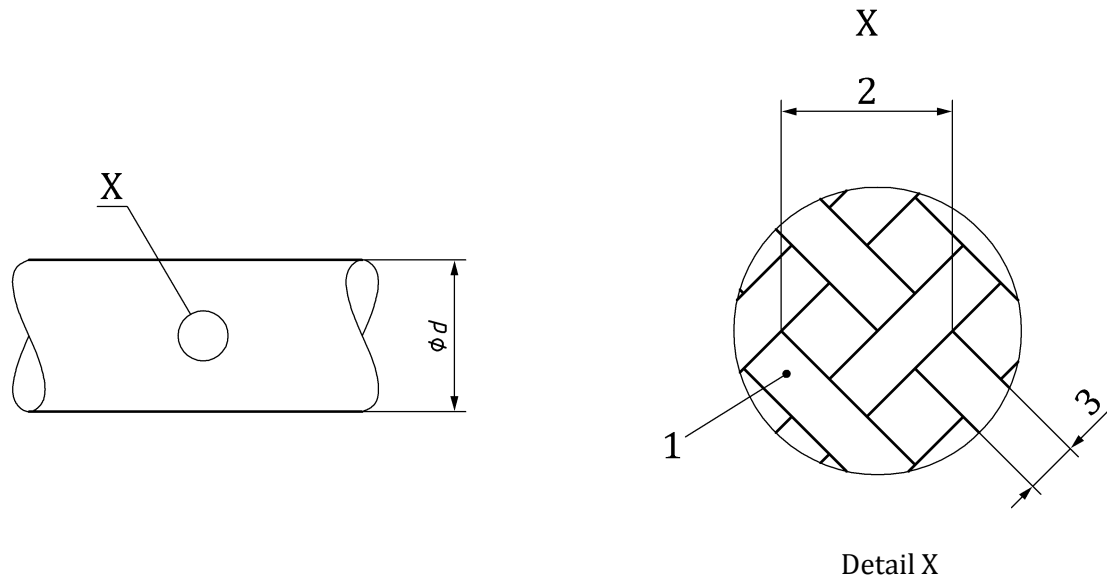

Key

- 1 braiding pattern
- 2 pitch
- 3 1 (one) tow
- d = Inner diameter

iTeh STANDARD PREVIEW (standards.iteh.ai)

[SIST EN 6049-004:2019](https://standards.iteh.ai/catalog/standards/sist/2a04364a-13ab-4600-9a5b-94481a96f78f/sist-en-6049-004-2019)

<https://standards.iteh.ai/catalog/standards/sist/2a04364a-13ab-4600-9a5b-94481a96f78f/sist-en-6049-004-2019>

Figure 1 — Composition of the sleeve

Table 1 — Dimensions and mass

Size code	Delivered mm	d		Nominal ^a mm	Mass max. ^b g/m
		mm min.	mm max.		
05	2	2	6	5	6,5
10	5	5	15	10	13
15	8	8	24	15	18
25	12	12	36	25	24
40	22	22	60	40	32

^a In practice approximately the maximum diameter of a cable bundle.
^b At the delivered diameter.

4.2 Color and materials

4.2.1 Color

Color shall be olive green, code 5.

EN 6049-004:2019 (E)**4.2.2 Materials**

The material shall be meta-aramid and meet the requirements as specified in this standard.

4.3 Mechanical properties**4.3.1 Sun light exposure**

After testing according to EN 6059-301 for 40 h, the retention of the tensile strength shall be 45 % minimum with respect to the determined values of non-tested tows.

4.3.2 Temperature range

The operation temperature of the protection sleeves shall be:

- maximum: + 240 °C;
- minimum: - 55 °C.

NOTE Above + 175 °C: loss of water repellent properties.

4.3.3 Resistance to fluids

After testing according to EN 6059-303, the retention of the tensile strength shall be 90 % minimum with respect to the determined values of non-tested tows.

4.3.4 Water absorption

To fulfil the requirements for water absorption, the sleeve shall repel water as tested in EN 6059-305 for 6 h. This test shall be executed after a high-temperature exposure test according to EN 6059-302 at + 175 °C. <https://standards.iteh.ai/catalog/standards/sist/2a04364a-13ab-4600-9a5b-94481a96f78f/sist-en-6049-004-2019>

4.3.5 Mould growth

After tested in accordance with EN 6059-306, there shall be no external deterioration which would affect service use and no mould growth visible to the naked eye.

4.3.6 Tensile strength of tows

The tensile force to be applied per dTEX shall not be less than 0,03 N. Degradation of the tensile strength after environmental tests shall be within the limits as mentioned in the relevant paragraph. For this test, unbraided tows of the batch which have been used for braiding of the sleeves may be used.

5 Test methods

The tests shall be carried out as shown in Table 3. For the number of samples to be tested, see EN 6049-001.