



SLOVENSKI STANDARD

SIST EN 12390-1:2021

01-september-2021

Nadomešča:
SIST EN 12390-1:2013

Preskušanje strjenega betona - 1. del: Oblika, mere in druge zahteve za vzorce in kalupe

Testing hardened concrete - Part 1: Shape, dimensions and other requirements for specimens and moulds

Prüfung von Festbeton - Teil 1: Form, Maße und andere Anforderungen für Probekörper und Formen

(standards.iteh.ai)

Essais pour béton durci - Partie 1 : Forme, dimensions et autres exigences aux éprouvettes et aux moules

<https://standards.iteh.ai/catalog/standards/sist/56edad04-50de-4dae-8fdc-b6fa36476ee5/sist-en-12390-1-2021>

Ta slovenski standard je istoveten z: EN 12390-1:2021

ICS:

91.100.30	Beton in betonski izdelki	Concrete and concrete products
-----------	---------------------------	--------------------------------

SIST EN 12390-1:2021

en,fr,de

iTeh STANDARD PREVIEW
(standards.iteh.ai)

[SIST EN 12390-1:2021](https://standards.iteh.ai/catalog/standards/sist/56edad04-50de-4dae-8fdc-b6fa36476ee5/sist-en-12390-1-2021)

<https://standards.iteh.ai/catalog/standards/sist/56edad04-50de-4dae-8fdc-b6fa36476ee5/sist-en-12390-1-2021>

EUROPEAN STANDARD
NORME EUROPÉENNE
EUROPÄISCHE NORM

EN 12390-1

July 2021

ICS 91.100.30

Supersedes EN 12390-1:2012

English Version

**Testing hardened concrete - Part 1: Shape, dimensions and
other requirements for specimens and moulds**

Essais pour béton durci - Partie 1 : Forme, dimensions
et autres exigences aux éprouvettes et aux moules

Prüfung von Festbeton - Teil 1: Form, Maße und andere
Anforderungen für Probekörper und Formen

This European Standard was approved by CEN on 7 June 2021.

CEN members are bound to comply with the CEN/CENELEC Internal Regulations which stipulate the conditions for giving this European Standard the status of a national standard without any alteration. Up-to-date lists and bibliographical references concerning such national standards may be obtained on application to the CEN-CENELEC Management Centre or to any CEN member.

This European Standard exists in three official versions (English, French, German). A version in any other language made by translation under the responsibility of a CEN member into its own language and notified to the CEN-CENELEC Management Centre has the same status as the official versions.

CEN members are the national standards bodies of Austria, Belgium, Bulgaria, Croatia, Cyprus, Czech Republic, Denmark, Estonia, Finland, France, Germany, Greece, Hungary, Iceland, Ireland, Italy, Latvia, Lithuania, Luxembourg, Malta, Netherlands, Norway, Poland, Portugal, Republic of North Macedonia, Romania, Serbia, Slovakia, Slovenia, Spain, Sweden, Switzerland, Turkey and United Kingdom.

<https://standards.iteh.ai/catalog/standards/sist/56edad04-50de-4dae-8fdc-b6fa36476ee5/sist-en-12390-1-2021>



EUROPEAN COMMITTEE FOR STANDARDIZATION
COMITÉ EUROPÉEN DE NORMALISATION
EUROPÄISCHES KOMITEE FÜR NORMUNG

CEN-CENELEC Management Centre: Rue de la Science 23, B-1040 Brussels

Contents	Page
European foreword.....	3
1 Scope	5
2 Normative references	5
3 Terms and definitions	5
4 Shape, dimensions and tolerances of specimens	5
4.1 General	5
4.2 Cubes	6
4.2.1 Nominal sizes	6
4.2.2 Designated sizes	6
4.2.3 Tolerances	6
4.3 Cylinders	6
4.3.1 Nominal sizes	6
4.3.2 Designated sizes	7
4.3.3 Tolerances	7
4.3.4 Applicability of tolerances	7
4.4 Prisms	7
4.4.1 Nominal sizes	7
4.4.2 Designated sizes	7
4.4.3 Tolerances	8
4.5 Measurement of dimensions and shape of specimens	8
5 Moulds	8
5.1 General	8
5.2 Calibrated moulds	8
5.2.1 General	8
5.2.2 Calibrated moulds for cubical specimens	9
5.2.3 Calibrated moulds for cylindrical specimens	9
5.2.4 Calibrated moulds for prismatic specimens	9
Annex A (normative) Application of EN ISO 1101 to concrete test specimens and moulds	10
A.1 General	10
A.2 Flatness	10
A.3 Perpendicularity	11
A.4 Straightness	11
Annex B (normative) Assessment of flatness of specimens and moulds	12

iTech STANDARD PREVIEW
(standards.itech.ai)

SIST EN 12390-1:2021

[https://standards.itech.ai/catalog/standards/sist/56edad04-50de-4dae-8f8c-](https://standards.itech.ai/catalog/standards/sist/56edad04-50de-4dae-8f8c-b6636476ee5/sist-en-12390-1-2021)

[b6636476ee5/sist-en-12390-1-2021](https://standards.itech.ai/catalog/standards/sist/56edad04-50de-4dae-8f8c-b6636476ee5/sist-en-12390-1-2021)

European foreword

This document (EN 12390-1:2021) has been prepared by Technical Committee CEN/TC 104 “Concrete and related products”, the secretariat of which is held by SN.

This European Standard shall be given the status of a national standard, either by publication of an identical text or by endorsement, at the latest by January 2022, and conflicting national standards shall be withdrawn at the latest by January 2022.

Attention is drawn to the possibility that some of the elements of this document may be the subject of patent rights. CEN shall not be held responsible for identifying any or all such patent rights.

This document supersedes EN 12390-1:2012.

The following amendments have been made to the former edition:

- editorial revision;
- increases in the allowable tolerances for flatness of moulds and the dimensions of the specimens which reflect current industry practice.

This document is one of a series on testing concrete.

EN 12390, *Testing hardened concrete*, consists of the following parts:

- *Part 1: Shape, dimensions and other requirements for specimens and moulds;*
- *Part 2: Making and curing specimens for strength tests;*
- *Part 3: Compressive strength of test specimens;*
- *Part 4: Compressive strength – Specification for testing machines;*
- *Part 5: Flexural strength of test specimens;*
- *Part 6: Tensile splitting strength of test specimens;*
- *Part 7: Density of hardened concrete;*
- *Part 8: Depth of penetration of water under pressure;*
- *Part 10: Determination of the carbonation resistance of concrete at atmospheric levels of carbon dioxide;*
- *Part 11: Determination of the chloride resistance of concrete, unidirectional diffusion;*
- *Part 12: Determination of the potential carbonation resistance of concrete: Accelerated carbonation method;*
- *Part 13: Determination of secant modulus of elasticity in compression;*
- *Part 14: Semi-adiabatic method for the determination of heat released by concrete during its hardening process;*

EN 12390-1:2021 (E)

- *Part 15: Adiabatic method for the determination of heat released by concrete during its hardening process;*
- *Part 16: Determination of shrinkage of concrete;*
- *Part 17: Determination of creep of concrete in compression;*
- *Part 18: Determination of the chloride migration coefficient (in preparation).*

This document recognizes alternative approaches towards obtaining test specimens of the correct sizes and shapes. The first is to use moulds whose lives are limited and to measure the specimens to ensure conformity. The second is to cast specimens in calibrated metal moulds which meet tighter tolerances than for specimens. The use of calibrated moulds allows relaxation on the requirement for measuring the specimens.

Annex A gives the application of EN ISO 1101 to measuring the shapes of concrete test specimens and moulds.

Annex B gives a method to measure the flatness of specimens and moulds.

Any feedback and questions on this document should be directed to the users' national standards body. A complete listing of these bodies can be found on the CEN website.

According to the CEN-CENELEC Internal Regulations, the national standards organisations of the following countries are bound to implement this European Standard: Austria, Belgium, Bulgaria, Croatia, Cyprus, Czech Republic, Denmark, Estonia, Finland, France, Germany, Greece, Hungary, Iceland, Ireland, Italy, Latvia, Lithuania, Luxembourg, Malta, Netherlands, Norway, Poland, Portugal, Republic of North Macedonia, Romania, Serbia, Slovakia, Slovenia, Spain, Sweden, Switzerland, Turkey and the United Kingdom.

<https://standards.iteh.ai/catalog/standards/sist/56edad04-50de-4dae-8fdc-b6fa36476ee5/sist-en-12390-1-2021>

1 Scope

This document specifies the shapes, dimensions and tolerances of cast concrete test specimens in the form of cubes, cylinders and prisms, and of the moulds required to produce them.

NOTE The tolerances specified in this document are based on the needs of strength testing, but they can be applicable to tests for other properties.

2 Normative references

The following documents are referred to in the text in such a way that some or all of their content constitutes requirements of this document. For dated references, only the edition cited applies. For undated references, the latest edition of the referenced document (including any amendments) applies.

EN ISO 1101, *Geometrical product specifications (GPS) - Geometrical tolerancing - Tolerances of form, orientation, location and run-out (ISO 1101)*

EN 206, *Concrete – Specification, performance, production and conformity*

3 Terms and definitions

For the purposes of this document, the terms and definitions given in EN ISO 1101 and the following apply.

ISO and IEC maintain terminological databases for use in standardization at the following addresses:

- IEC Electropedia: available at <https://www.electropedia.org/>
- ISO Online browsing platform: available at <https://www.iso.org/obp>

3.1 nominal size commonly used description of specimen size

3.2 designated size

specimen size in millimetres, selected and declared by the user of this standard from amongst the allowed range of nominal sizes

4 Shape, dimensions and tolerances of specimens

4.1 General

For application of EN ISO 1101 to the measurement of concrete test specimens and moulds in respect to flatness, perpendicularity and straightness, see Annex A.

For each shape of test specimen, cube, cylinder and prism, the nominal size d (Figures 1, 2 and 3) should be chosen to be at least three and a half times the maximum aggregate size (D_{\max} according to EN 206) in the concrete.

EN 12390-1:2021 (E)

4.2 Cubes

4.2.1 Nominal sizes

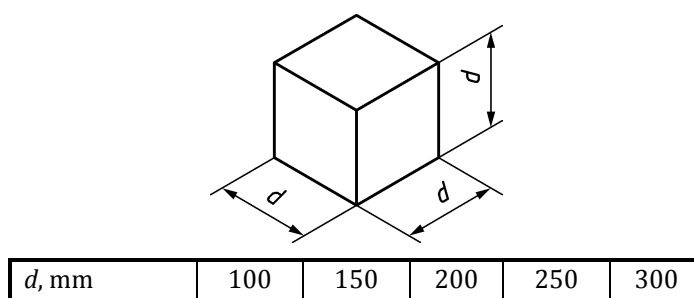

Figure 1 — Cube - nominal sizes

4.2.2 Designated sizes

Designated sizes may be selected within $\pm 10\%$ of the nominal size.

4.2.3 Tolerances

4.2.3.1 Between moulded surfaces the tolerance on the designated size (d) is 1,0 %.

4.2.3.2 Between the top trowelled face and the moulded bottom face the tolerance on the designated size is 1,5 %.

4.2.3.3 The tolerance on the flatness of the potential load bearing surfaces is $0,000\ 6d$ mm (see Annex B).

SIST EN 12390-1:2021

<https://standards.iteh.ai/catalog/standards/sist/56cedad04-50de-4dae-8fdc-906127200000/en-12390-1-2021>

4.2.3.4 The tolerance on the perpendicularity of the sides of the cube, with reference to the base, as cast, is 0,5 mm.

4.3 Cylinders

4.3.1 Nominal sizes

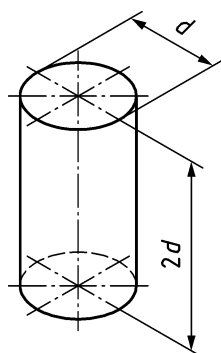

d , mm	100	113 ^a	150	200	250	300
^a This has a load-bearing area of 10 000 mm ² .						

Figure 2 — Cylinder - nominal size

4.3.2 Designated sizes

Designated sizes may be selected within $\pm 10\%$ of the nominal size.

4.3.3 Tolerances

4.3.3.1 The tolerance on the designated diameter (d) is $1,0\%$.

4.3.3.2 The tolerance on the flatness of the load-bearing surface is $0,000\ 6d$ mm (see Annex B).

4.3.3.3 The tolerance on the perpendicularity of the side, with reference to the end faces, is $0,00\ 7d$ mm.

4.3.3.4 The tolerance on the height ($2d$) is 5% .

4.3.3.5 For specimens to be used for the tensile splitting strength test, the straightness tolerance on the generating line of the cylinder is $0,2$ mm.

4.3.4 Applicability of tolerances

4.3.4.1 Specimens with moulded end faces, or with end faces adjusted by grinding, shall conform to 4.3.3.

4.3.4.2 Specimens with end faces adjusted using sulfur capping, high alumina cement capping, or similar capping shall conform to 4.3.3.1 before capping and to 4.3.3.2, 4.3.3.3 and 4.3.3.4 after capping.

4.3.4.3 Specimens with end faces adjusted using the sandbox method or similar methods shall conform to 4.3.3.1 and 4.3.3.4 before capping and to 4.3.3.3 after fixing the box(es).

4.4 Prisms

SIST EN 12390-1:2021
<https://standards.iteh.ai/catalog/standards/sist/56edad04-50de-4dae-8fdc-b6fa36476ee5/sist-en-12390-1-2021>

4.4.1 Nominal sizes

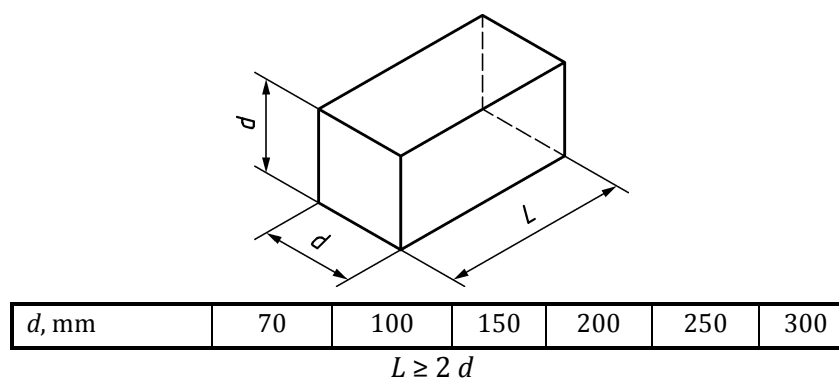

Figure 3 — Prism - nominal sizes

4.4.2 Designated sizes

Designated sizes (d) may be selected within $\pm 10\%$ of the nominal sizes.

EN 12390-1:2021 (E)**4.4.3 Tolerances**

4.4.3.1 Between moulded surfaces, the tolerance on the designated size (d) is 1,0 %.

4.4.3.2 Between the top trowelled face and the bottom moulded face, the tolerance on the designated size is 1,5 %.

4.4.3.3 The tolerance on the perpendicularity of the sides of the prism with reference to the base, as cast, is 0,5 mm.

4.4.3.4 The tolerances on the straightness of the line on the surface to be in contact with the rollers in the flexural strength test is 0,3 mm.

4.4.3.5 For specimens to be used for the tensile splitting strength test, the straightness tolerance on the load bearing surface is 0,3 mm.

4.5 Measurement of dimensions and shape of specimens

4.5.1 Unless specimens have documentation to show that they had been made in calibrated moulds, they shall be measured or checked for conformity to 4.2, 4.3 or 4.4 as appropriate.

NOTE Go/no-go gauges or other suitable method can be used to check dimensions.

4.5.2 If specimens have documentation to show that they have been made in calibrated moulds, only the requirements of 4.2.3.1 and 4.2.3.2 or 4.3.3.1, 4.3.3.2 and 4.3.3.4 or 4.4.3.1, 4.4.3.2, for cubes, cylinder or prisms, respectively, shall be checked.

NOTE 1 Go/no-go gauges or other suitable method can be used to check dimensions.

NOTE 2 If a surface, calibrated with respect to flatness, is used to form the load bearing surface of cylinders, 4.3.3.2 need not be performed.

NOTE 3 Guidance on the measurement of flatness of load-bearing surfaces is given in Annex B.

5 Moulds**5.1 General**

Moulds shall be watertight and non-absorbent.

NOTE The joints of moulds can be coated with wax, oil or grease to achieve water-tightness.

Moulds, other than calibrated moulds in accordance with 5.2, may be made from any material which is suitable for producing concrete specimens.

5.2 Calibrated moulds**5.2.1 General**

Calibrated moulds shall be made of steel or cast iron, which shall be the reference materials. If moulds are manufactured from other materials, in-use performance test data shall be available which demonstrates long-term equivalence with steel or cast iron calibrated moulds.

All parts of calibrated moulds shall be sufficiently robust to prevent distortion on assembly and in use.

The components of the mould, with the possible exception of the base plate, shall have identification marks.