Castors and wheels — Requirements for castors for hospital beds

Roues et roulettes — Exigences pour roulettes pour lits d'hôpitaux

iTeh STANDARD PREVIEW
(standards.iteh.ai)

[ISO 22882:2016](https://standards.iteh.ai/catalog/standards/sist/dc32cd17-c675-4cdf-8419-fe3534ccb74e/iso-22882-2016)

[https://standards.iteh.ai/catalog/standards/sist/dc32cd17-c675-4cdf-8419-
fe3534ccb74e/iso-22882-2016](https://standards.iteh.ai/catalog/standards/sist/dc32cd17-c675-4cdf-8419-fe3534ccb74e/iso-22882-2016)



iTeh STANDARD PREVIEW
(standards.iteh.ai)

ISO 22882:2016

<https://standards.iteh.ai/catalog/standards/sist/dc32cd17-c675-4cdf-8419-fe3534ccb74e/iso-22882-2016>



COPYRIGHT PROTECTED DOCUMENT

© ISO 2016, Published in Switzerland

All rights reserved. Unless otherwise specified, no part of this publication may be reproduced or utilized otherwise in any form or by any means, electronic or mechanical, including photocopying, or posting on the internet or an intranet, without prior written permission. Permission can be requested from either ISO at the address below or ISO's member body in the country of the requester.

ISO copyright office
Ch. de Blandonnet 8 • CP 401
CH-1214 Vernier, Geneva, Switzerland
Tel. +41 22 749 01 11
Fax +41 22 749 09 47
copyright@iso.org
www.iso.org

Contents

	Page
Foreword	v
Introduction	vi
1 Scope	1
2 Normative references	1
3 Terms and definitions	1
4 Dimensions and classification	1
4.1 Characteristics.....	1
4.2 Dimensions.....	1
4.3 Fixing system.....	2
4.4 Load capacity.....	3
5 Requirements for testing	3
5.1 General.....	3
5.2 Standard conditions.....	3
5.2.1 Environmental conditions.....	3
5.2.2 Test sequence.....	3
5.3 Initial wheel play.....	4
5.3.1 Test objectives, apparatus and procedures.....	4
5.3.2 Acceptance criteria.....	4
5.4 Initial swivel play.....	4
5.4.1 Test objectives, apparatus and procedures.....	4
5.4.2 Acceptance criteria.....	4
5.5 Electrical resistance test.....	4
5.5.1 Test objectives, apparatus and procedures.....	4
5.5.2 Test values.....	4
5.5.3 Tolerances.....	5
5.5.4 Acceptance criteria.....	5
5.6 Fatigue test for locking/braking device.....	5
5.6.1 Test objectives, apparatus and procedures.....	5
5.6.2 Test values.....	5
5.6.3 Tolerances.....	5
5.6.4 Acceptance criteria.....	6
5.7 Efficiency check of wheel braking and/or locking device.....	6
5.7.1 Test objectives, apparatus and procedures.....	6
5.7.2 Test values.....	6
5.7.3 Tolerances.....	6
5.7.4 Acceptance criteria.....	6
5.8 Efficiency check of swivel braking and/or locking device.....	6
5.8.1 Test objectives, apparatus and procedures.....	6
5.8.2 Test values.....	6
5.8.3 Tolerances.....	7
5.8.4 Acceptance criteria.....	7
5.9 Static test.....	7
5.9.1 Test objectives, apparatus and procedures.....	7
5.9.2 Test values.....	7
5.9.3 Tolerances.....	7
5.9.4 Acceptance criteria.....	8
5.10 Dynamic test.....	8
5.10.1 Test objectives, apparatus and procedures.....	8
5.10.2 Test values.....	8
5.10.3 Tolerances.....	8
5.10.4 Acceptance criteria.....	9
5.11 Efficiency check of wheel braking and/or locking device.....	9

5.12	Efficiency check of swivel braking and/or locking device.....	9
5.13	Final wheel play.....	9
5.13.1	Test objectives, apparatus and procedures.....	9
5.13.2	Acceptance criteria.....	9
5.14	Final swivel play.....	10
5.14.1	Test objectives, apparatus and procedures.....	10
5.14.2	Acceptance criteria.....	10
6	Conformity.....	10
7	Marking.....	10
7.1	Product marking.....	10
7.2	Marking of electrically conductive or antistatic castors/wheels.....	10
	Bibliography.....	11

iTeh STANDARD PREVIEW
(standards.iteh.ai)

ISO 22882:2016

<https://standards.iteh.ai/catalog/standards/sist/dc32cd17-c675-4cdf-8419-fe3534ccb74e/iso-22882-2016>

Foreword

ISO (the International Organization for Standardization) is a worldwide federation of national standards bodies (ISO member bodies). The work of preparing International Standards is normally carried out through ISO technical committees. Each member body interested in a subject for which a technical committee has been established has the right to be represented on that committee. International organizations, governmental and non-governmental, in liaison with ISO, also take part in the work. ISO collaborates closely with the International Electrotechnical Commission (IEC) on all matters of electrotechnical standardization.

The procedures used to develop this document and those intended for its further maintenance are described in the ISO/IEC Directives, Part 1. In particular the different approval criteria needed for the different types of ISO documents should be noted. This document was drafted in accordance with the editorial rules of the ISO/IEC Directives, Part 2 (see www.iso.org/directives).

Attention is drawn to the possibility that some of the elements of this document may be the subject of patent rights. ISO shall not be held responsible for identifying any or all such patent rights. Details of any patent rights identified during the development of the document will be in the Introduction and/or on the ISO list of patent declarations received (see www.iso.org/patents).

Any trade name used in this document is information given for the convenience of users and does not constitute an endorsement.

For an explanation on the meaning of ISO specific terms and expressions related to conformity assessment, as well as information about ISO's adherence to the World Trade Organization (WTO) principles in the Technical Barriers to Trade (TBT) see the following URL: www.iso.org/iso/foreword.html.

The committee responsible for this document is ISO/TC 110, *Industrial trucks*.

This second edition results from the reinstatement of ISO 22882:2004, which was withdrawn in 2014 and with which it is technically identical.

Introduction

The industry stakeholders have expressed the need for this important International Standard. Therefore, the interested parties agreed to republish the withdrawn International Standard as a new edition.

In order to ensure that the International Standard will be actively used in the ISO member countries worldwide, procedures may be necessary to replace the existing national standards and technical regulations by the International Standard.

Only by these actions will there be a guarantee that products in accordance with International Standards can be shipped worldwide freely without any technical barriers.

iTeh STANDARD PREVIEW (standards.iteh.ai)

[ISO 22882:2016](https://standards.iteh.ai/catalog/standards/sist/dc32cd17-c675-4cdf-8419-fe3534ccb74e/iso-22882-2016)

[https://standards.iteh.ai/catalog/standards/sist/dc32cd17-c675-4cdf-8419-
fe3534ccb74e/iso-22882-2016](https://standards.iteh.ai/catalog/standards/sist/dc32cd17-c675-4cdf-8419-fe3534ccb74e/iso-22882-2016)

Castors and wheels — Requirements for castors for hospital beds

1 Scope

This document specifies the technical requirements, the appropriate dimensions and the requirements for the testing of swivel castors for hospital beds with a wheel diameter of 100 mm or more and which have a central locking device. Swivel castors may be used with the main principal dimensions.

2 Normative references

The following documents are referred to in the text in such a way that some or all of their content constitutes requirements of this document. For dated references, only the edition cited applies. For undated references, the latest edition of the referenced document (including any amendments) applies.

ISO 22878:2004, *Castors and wheels — Test methods and apparatus*

3 Terms and definitions

For the purposes of this document, the terms and definitions given in ISO 22877 apply.

ISO and IEC maintain terminological databases for use in standardization at the following addresses:

- IEC Electropedia: available at <http://www.electropedia.org/>
- ISO Online browsing platform: available at <http://www.iso.org/obp>

NOTE Symbols are given in ISO 22878:2004, Annex A.

4 Dimensions and classification

4.1 Characteristics

The characteristics of a castor are as follows:

- wheel diameter;
- overall height;
- offset;
- fixing system;
- load capacity.

4.2 Dimensions

The dimensions listed in [Table 1](#) and shown in [Figure 1](#) shall be used.

For dimensions of non-central locking castors used in hospital beds, refer to the relevant tables in ISO 22881.

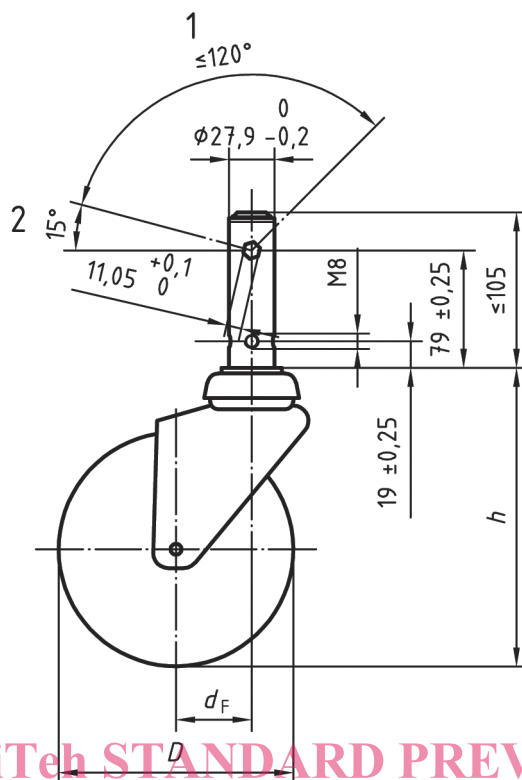

iTeh STANDARD PREVIEW
(standards.iteh.ai)

Key

- 1 working angle
- 2 unlocked position

ISO 22882:2016

<https://standards.iteh.ai/catalog/standards/sist/dc32cd17-c675-4cdf-8419-fe3534ccb74e/iso-22882-2016>

Figure 1 — Principal dimensions of the central locking fixing system

Table 1

Wheel diameter ^a	Overall height ^b	Offset ^b
D	h	d_F
100	150	46
125	175	56
150	200	65
200	250	70
250	300	80
^a Tolerance ± 1 %.		
^b Maximum.		

4.3 Fixing system

The principal dimensions of the fixing system with the central locking are as follows:

- stem length;
- stem diameter;
- distance of the threaded hole centre from the stem collar;
- thread size;

- distance of the hexagon hole centre from the stem collar;
- dimension of the hexagon hole;
- working angle of the hexagon hole.

4.4 Load capacity

This is the maximum load, in newtons, which can be carried by a wheel or a castor so as to fully comply with the required acceptance criteria.

5 Requirements for testing

5.1 General

Test methods and apparatus shall be as specified in ISO 22878.

5.2 Standard conditions

5.2.1 Environmental conditions

Tests shall be carried out at a temperature between 15 °C and 28 °C. During the 24 h prior to the test, the samples shall remain at the specified temperature, in an environment with a relative humidity between 40 % and 70 %.

Samples shall not be artificially cooled during testing.

5.2.2 Test sequence

Tests, where relevant, shall be carried out in the sequence shown in [Table 2](https://standards.iteh.ai/catalog/standards/sist/dc32cd17-c675-4cdf-8419-1c5554cc074c/iso-22882-2016).

Table 2

Reference in this document	Test sequence	Castor types	Test procedure given in ISO 22878:2004
5.3	Initial wheel play	All	4.2
5.4	Initial swivel play	Swivel castors with or without accessories	4.3
5.5	Electrical resistance	Castors antistatic or electrically conductive	4.4
5.6	Fatigue test for locking/braking device	Castors with a central locking/braking device	4.5
5.7	Efficiency check of wheel braking and/or locking device	Castors with a central locking/braking device	4.6
5.8	Efficiency check of swivel braking and/or locking device	Castors with a central locking/braking device	4.7
5.9	Static test	All	4.9
5.10	Dynamic test	All	4.8
5.11	Efficiency check of wheel braking and/or locking device	Castors with a central locking/braking device	4.6
5.12	Efficiency check of swivel braking and/or locking device	Castors with a central locking/braking device	4.7
5.13	Final wheel play	All	4.2
5.14	Final wheel play	Swivel castors with or without accessories	4.3