**Footwear — Test methods for whole
shoe — Upper sole adhesion**

*Chaussures — Méthodes d'essai applicables à la chaussure entière —
Liaison tige/semelle*

iTeh STANDARD PREVIEW
(standards.iteh.ai)

[ISO 17708:2018](https://standards.iteh.ai/catalog/standards/sist/66cdbdcd-b8e2-47be-b2ce-fc8b7f1c203c/iso-17708-2018)

[https://standards.iteh.ai/catalog/standards/sist/66cdbdcd-b8e2-47be-b2ce-
fc8b7f1c203c/iso-17708-2018](https://standards.iteh.ai/catalog/standards/sist/66cdbdcd-b8e2-47be-b2ce-fc8b7f1c203c/iso-17708-2018)



iTeh STANDARD PREVIEW
(standards.iteh.ai)

ISO 17708:2018

<https://standards.iteh.ai/catalog/standards/sist/66cdbcdd-b8e2-47be-b2ce-fc8b7f1c203c/iso-17708-2018>



COPYRIGHT PROTECTED DOCUMENT

© ISO 2018

All rights reserved. Unless otherwise specified, or required in the context of its implementation, no part of this publication may be reproduced or utilized otherwise in any form or by any means, electronic or mechanical, including photocopying, or posting on the internet or an intranet, without prior written permission. Permission can be requested from either ISO at the address below or ISO's member body in the country of the requester.

ISO copyright office
CP 401 • Ch. de Blandonnet 8
CH-1214 Vernier, Geneva
Phone: +41 22 749 01 11
Fax: +41 22 749 09 47
Email: copyright@iso.org
Website: www.iso.org

Published in Switzerland

Contents

	Page
Foreword	iv
1 Scope	1
2 Normative references	1
3 Terms and definitions	1
4 Apparatus and material	1
5 Sampling and conditioning	2
5.1 Footwear conditioning	2
5.2 Number of samples	2
5.3 Preparation of test pieces	2
5.3.1 Upper-sole adhesion: construction type a	2
5.3.2 Upper-sole adhesion: construction types b, c, d and e	2
5.3.3 Sole-interlayer adhesion: construction types f and g	3
6 Test method	5
6.1 Principle	5
6.2 Procedure	5
7 Expression of results	7
7.1 Determination of the upper-sole adhesion	7
7.2 Evaluation of the mode of the bond failure	7
8 Test report	9
Annex A (normative) Ageing process conditions for the upper-sole bonding test	10
Bibliography	11

iTeH STANDARD PREVIEW
(standards.iteh.ai)

ISO 17708:2018

<https://standards.iteh.ai/catalog/standards/sist/66cdbcdd-b8e2-47be-b2ce-fc8b7f1c203c/iso-17708-2018>

Foreword

ISO (the International Organization for Standardization) is a worldwide federation of national standards bodies (ISO member bodies). The work of preparing International Standards is normally carried out through ISO technical committees. Each member body interested in a subject for which a technical committee has been established has the right to be represented on that committee. International organizations, governmental and non-governmental, in liaison with ISO, also take part in the work. ISO collaborates closely with the International Electrotechnical Commission (IEC) on all matters of electrotechnical standardization.

The procedures used to develop this document and those intended for its further maintenance are described in the ISO/IEC Directives, Part 1. In particular the different approval criteria needed for the different types of ISO documents should be noted. This document was drafted in accordance with the editorial rules of the ISO/IEC Directives, Part 2 (see www.iso.org/directives).

Attention is drawn to the possibility that some of the elements of this document may be the subject of patent rights. ISO shall not be held responsible for identifying any or all such patent rights. Details of any patent rights identified during the development of the document will be in the Introduction and/or on the ISO list of patent declarations received (see www.iso.org/patents).

Any trade name used in this document is information given for the convenience of users and does not constitute an endorsement.

For an explanation on the voluntary nature of standards, the meaning of ISO specific terms and expressions related to conformity assessment, as well as information about ISO's adherence to the World Trade Organization (WTO) principles in the Technical Barriers to Trade (TBT) see the following URL: www.iso.org/iso/foreword.html. (standards.iteh.ai)

This document was prepared by Technical Committee ISO/TC 216, *Footwear*.

This second edition cancels and replaces the first edition (ISO 17708:2003) which has been technically revised.

This document is based on EN 344.

Footwear — Test methods for whole shoe — Upper sole adhesion

1 Scope

This document describes a test method for determining the resistance to separation of the upper from the outsole, for separating adjacent layers of the outsole or for causing tear failure of the upper or the sole. It also defines conditions of ageing that can be used for production control.

This document is applicable to all types of footwear (cementing, vulcanisation, injection moulding, etc.) where the evaluation of sole adhesion on the upper is needed and where the upper is continuously assembled (closed shoe).

NOTE 1 In all cases the objective is to test the bond strength nearest to the edge of the assembly.

NOTE 2 The test need not be carried out when the bond has been made by grindery (using, for example, nails or screws) or stitching.

2 Normative references

The following documents are referred to in the text in such a way that some or all of their content constitutes requirements of this document. For dated references, only the edition cited applies. For undated references, the latest edition of the referenced document (including any amendments) applies.

ISO 18454, *Footwear — Standard atmospheres for conditioning and testing of footwear and components for footwear* <https://standards.iteh.ai/catalog/standards/sist/66cdbcdd-b8e2-47be-b2ce-f8b71c203c/iso-17708-2018>

ISO 7500-1, *Metallic materials — Calibration and verification of static uniaxial testing machines — Part 1: Tension/compression testing machines — Calibration and verification of the force-measuring system*

3 Terms and definitions

For the purposes of this document, the following terms and definitions apply.

ISO and IEC maintain terminological databases for use in standardization at the following addresses:

- ISO Online browsing platform: available at <https://www.iso.org/obp>
- IEC Electropedia: available at <http://www.electropedia.org/>

3.1

upper-sole adhesion

force required to separate the sole-upper bonding

4 Apparatus and material

The following apparatus and material shall be used.

4.1 Cutting device.

Sharp tool for clean cutting of the test pieces.

4.2 Tensile testing machine.

The tensile-testing machine shall comply with the requirements of ISO 7500-1 to an accuracy corresponding to class 2, with a constant rate of traverse of 100 mm/min \pm 10 mm/min, and it shall be able to measure a force range of 0 N to 600 N. The machine shall be fitted with either pincer or flat jaws (depending on the type of construction of the test sample), 25 mm to 30 mm wide, capable of firmly gripping the test pieces.

A low-inertia machine having autographic force recording facilities is essential.

4.3 Measuring device.

Calibrated device for measuring of the width of the upper bonding margin, with an accuracy of at least $\pm 0,5$ mm.

5 Sampling and conditioning

5.1 Footwear conditioning

Before dismantling and cutting of the test pieces, condition the footwear according to ISO 18454 for at least 24 h, and, if required, carry out an ageing process according to [Annex A](#).

NOTE Some adhesives cannot reach full strength for some time after application, therefore, when samples are taken directly from production, allow at least 72 h conditioning before carrying out the test.

5.2 Number of samples

For each model, the minimum number of samples shall be two items of footwear.

5.3 Preparation of test pieces

5.3.1 Upper-sole adhesion: construction type a

See [Figure 1](#).

Take a test piece from either the inner or the outer joint region.

Cut the test piece at X-X and Y-Y with sides at right angles to the edge of the sole using a press knife or bandsaw (see [4.1](#)) to cut through the upper, innersole or outsole to produce a test piece about 25 mm wide. The length of the upper and sole shall be about 15 mm measured from the feather line (see [Figure 2](#)). Remove the insole.

5.3.2 Upper-sole adhesion: construction types b, c, d and e

See [Figure 1](#).

Take a test piece from either the inner or outer joint region.

Cut the upper and sole at X-X and Y-Y to produce a test piece with a width of about 10 mm and an effective stripping length from shank to tip (toe-cap). Remove the insole.

Separate the upper from the sole for a length of about 10 mm to 20 mm by inserting a hot knife in the adhesive layer (see [Figure 3](#)).

NOTE It is considered that a construction is c or d when the distance from the X-X to the upper face of the insole is at least 8 mm.

5.3.3 Sole-interlayer adhesion: construction types f and g

See [Figure 1](#).

Take a test piece from either the inner or the outer joint region.

Remove the upper by cutting along the feather line at X-X. Remove the insole and other elements, such as the welt, if present. Cut a strip parallel to and including the sole edge at Y-Y to produce a test piece about 15 mm wide and at least 50 mm long.

Separate the sole layers for a length of about 10 mm to 20 mm by inserting a hot knife into the adhesive layer (see [Figure 3](#)).

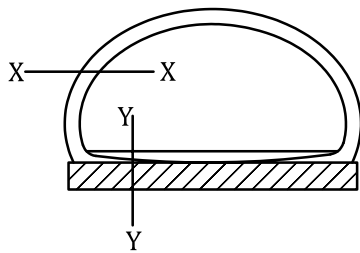

Type a: Conventional lasting

Cemented or moulded outsole having an extended edge

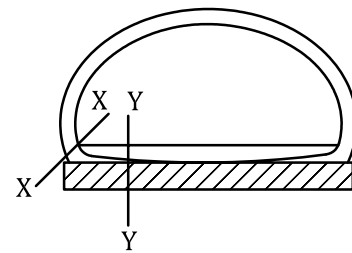

Type b: Conventional lasting

Close trimmed outsole

iTeh STANDARD PREVIEW
(standards.iteh.ai)

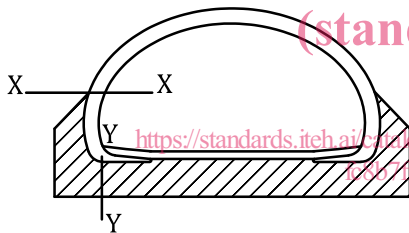

Type c: Conventional lasting

Direct injected or vulcanized outsole or cemented dished outsole

ISO 17708:2018
<https://standards.iteh.ai/catalog/standards/sist/66cdbcdd-b8e2-4770-b2ce-769b71c203c/iso-17708-2018>

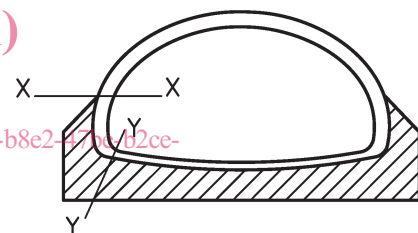

Type d: Strobel stitched

Cemented dished outsole or direct injected or vulcanized outsole

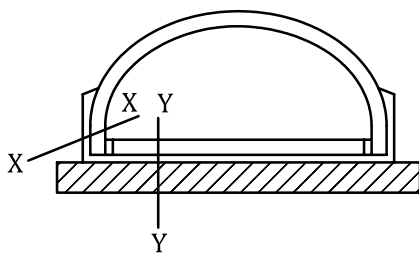

Type e: Conventional lasting or strobel stitched with rubber mudguard and cemented outsole

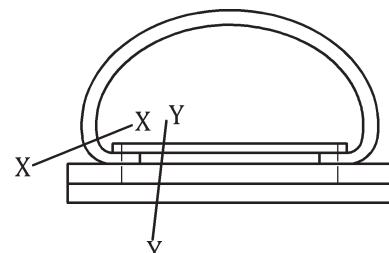

Type f: Machine sewn or welted where the outsole is bonded to the throughsole

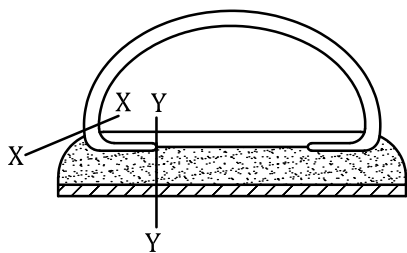

Type g: Multilayered sole

It may be moulded-on sole, a moulded unit or a built unit

Figure 1 — Types of construction showing positions for preparation of the test piece for bond strength

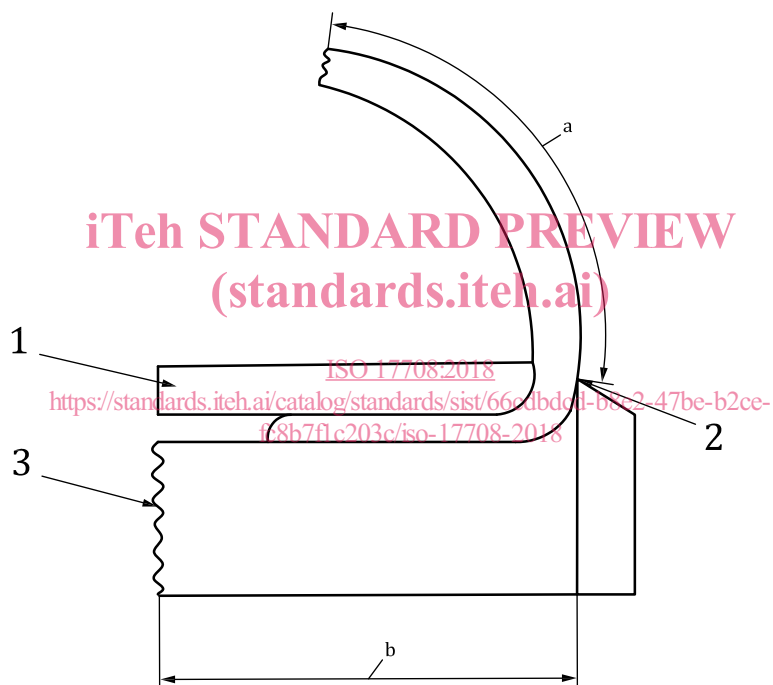

Key

- 1 insole (removed)
- 2 feather line
- 3 outsole
- a Approximately 15 mm.
- b Approximately 15 mm.

Figure 2 — Cross section of the test piece of construction type

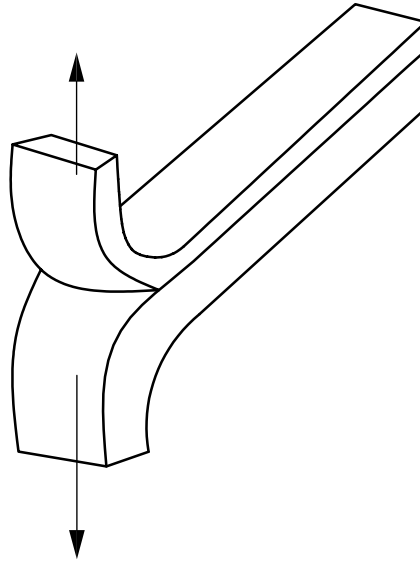

Figure 3 — Prepared test piece

6 Test method

6.1 Principle

Measurement of the force required to separate the upper from the outsole, using a tensile machine with a continuously recording load.

6.2 Procedure

6.2.1 Before carrying out the test, measure the width of the test piece, to the nearest millimetre, at five points using a measuring device with accuracy $\pm 0,5$ mm and calculate the average value, A , to the nearest millimetre.

6.2.2 Then measure the upper-sole adhesion according to the following method.

6.2.2.1 Upper-sole adhesion: Construction type a. Clamp the test piece into the jaws of the tensile machine, using a pincer jaw to grip the short edge of the sole (see [Figure 4](#)), and record the force/deformation graph at a separation speed of $100 \text{ mm/min} \pm 20 \text{ mm/min}$. After testing, observe the appearance of the separated areas and classify it according to [7.2](#).

6.2.2.2 Upper-sole adhesion: Construction types b, c, d and e and sole-interlayer adhesion: construction types f and g. Clamp the separated ends of the test piece in the flat jaws and record the