



Designation: ~~C1352-96 (Reapproved 2008)~~ Designation: C 1352/C 1352M - 09

## Standard Test Method for Flexural Modulus of Elasticity of Dimension Stone<sup>1</sup>

This standard is issued under the fixed designation C 1352/C 1352M; the number immediately following the designation indicates the year of original adoption or, in the case of revision, the year of last revision. A number in parentheses indicates the year of last reapproval. A superscript epsilon ( $\epsilon$ ) indicates an editorial change since the last revision or reapproval.

### 1. Scope

1.1 This test method covers the procedure for determining the flexural modulus of elasticity of stone by using a simple beam with quarter-point loading.

1.2 Stone tests may be made with load applied perpendicular to the bedding plane or rift and with load applied parallel to the bedding plane or rift.

1.3 Stone tests may be made for wet and dry specimen conditions.

1.4 The specifier of the test shall determine which conditions shall be used.

~~1.5 The values stated in SI units are to be regarded as the standard. The values given in parentheses are for information only.~~

1.5 *Units*—The values stated in either SI units or inch-pound units are to be regarded separately as standard. The values stated in each system may not be exact equivalents; therefore, each system shall be used independently of the other. Combining values from the two systems may result in non-conformance with the standard.

1.6 *This standard does not purport to address all of the safety concerns, if any, associated with its use. It is the responsibility of the user of this standard to establish appropriate safety and health practices and determine the applicability of regulatory limitations prior to use.*

### 2. Referenced Documents

2.1 *ASTM Standards:*<sup>2</sup>

C 119 [Terminology Relating to Dimension Stone](#)

C 880 [Test Method for Flexural Strength of Dimension Stone](#)

E 4 [Practices for Force Verification of Testing Machines](#)

### 3. Terminology

3.1 *Definition*

3.1 *Definitions*—For definitions of terms used in this test method, refer to Terminology C 119.

3.2 *Definitions of Terms Specific to This Standard:*

3.2.1 *modulus of elasticity, n*—stress per unit strain, also known as Young's Modulus.

### 4. Significance and Use

4.1 This test method is useful for providing engineering values for stress and deflection analysis of stone panels. It is also useful in indicating the differences in flexural modulus of elasticity between various dimension stones and stones of the same type in different loading directions (parallel and perpendicular to rift or bedding planes).

### 5. Apparatus

5.1 *Testing Machine* (see Fig. 1), conforming to the requirements of the applicable sections of Practices E 4. The quarter-point loading method shall be used in making flexure tests of stone employing bearing blocks that will ensure that forces applied to the beam will be vertical only and applied without eccentricity. The apparatus should be capable of maintaining the span length and distances between load-applying blocks and support blocks constant within  $\pm 1.3 \text{ mm}$  ( $\pm 0.05 \text{ in.}$ ),  $\pm 0.05 \text{ in.}$  [ $\pm 1 \text{ mm}$ ]. The load should be capable of being applied at a uniform rate and in such a manner as to avoid shock.

5.2 *Deflection Gages*, capable of reading to  $0.002 \text{ mm}$  ( $0.0001 \text{ in.}$ ),  $0.0001 \text{ in.}$  [ $0.002 \text{ mm}$ ] shall be used to measure mid-span deflections at the two free edges and support deflections at each end.

<sup>1</sup> This test method is under the jurisdiction of ASTM Committee C18 on Dimension Stone and is the direct responsibility of Subcommittee C18.01 on Test Methods. Current edition approved ~~Oct. April 1, 2008-2009~~. Published ~~December 2008-April 2009~~. Originally approved in 1996. Last previous edition approved in ~~2002-2008~~ as ~~E1352-96(2002)-C 1352-96(2008)~~.

<sup>2</sup> For referenced ASTM standards, visit the ASTM website, [www.astm.org](http://www.astm.org), or contact ASTM Customer Service at [service@astm.org](mailto:service@astm.org). For *Annual Book of ASTM Standards* volume information, refer to the standard's Document Summary page on the ASTM website.

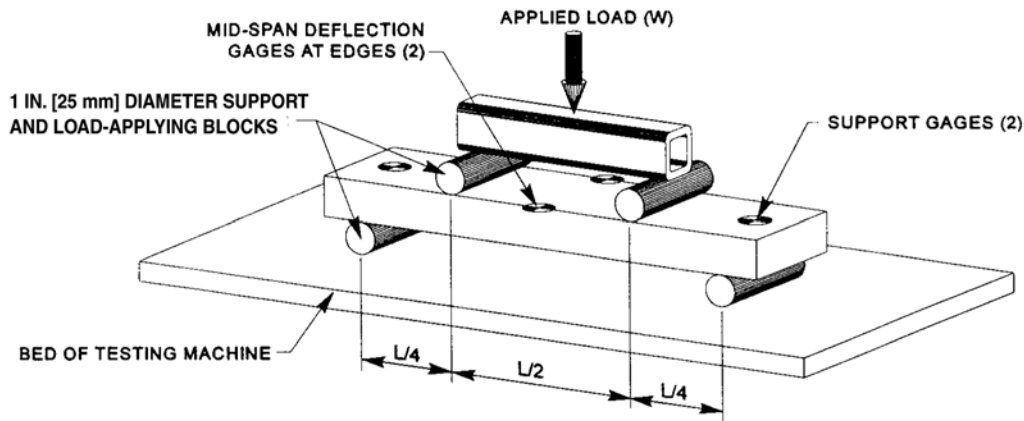

FIG. 1 Diagrammatic View of a Suitable Apparatus for Flexural Modulus of Elasticity of Stone Test

## 6. Test Specimens

6.1 The test specimens shall measure  $100\text{ mm}$  ( $4\text{ in.}$ )  $4\text{ in.}$  [ $100\text{ mm}$ ] wide by  $32\text{ mm}$  ( $1.25\text{ in.}$ )  $1.25\text{ in.}$  [ $30\text{ mm}$ ] thick by  $380\text{ mm}$  ( $15\text{ in.}$ )  $15\text{ in.}$  [ $350\text{ mm}$ ] long with a span as tested of  $320\text{ mm}$  ( $12.5\text{ in.}$ )  $12.5\text{ in.}$  [ $300\text{ mm}$ ]. The sides of the specimens shall be at right angles with the top and bottom. The specimens shall have a fine abrasive finish on the planes perpendicular to the load and a fine saw finish on the other four planes. The dimensions of the specimen shall be measured and recorded to the nearest  $0.2\text{ mm}$  ( $0.01\text{ in.}$ )  $0.01\text{ in.}$  [ $0.1\text{ mm}$ ]. A minimum of five specimens shall be tested for each condition of test. The average value calculated from plots of the test results is reported as the flexural modulus of elasticity for that condition.

6.2 Where the job thickness has been set (the thickness of the stone panels for the project has been established), it is often requested to perform flexural modulus of elasticity tests at the job thickness. The following shall govern the specimen size where it is requested to test at the job thickness, and the job thickness is other than  $32\text{ mm}$  ( $1.25\text{ in.}$ )  $1.25\text{ in.}$  [ $30\text{ mm}$ ]. The span as tested shall be ten times the thickness. The specimen lengths shall be not less than  $50\text{ mm}$  ( $2\text{ in.}$ )  $2\text{ in.}$  [ $50\text{ mm}$ ] and not more than  $100\text{ mm}$  ( $4\text{ in.}$ )  $4\text{ in.}$  [ $100\text{ mm}$ ] greater than the span as tested. Where the thickness is less than  $70\text{ mm}$  ( $2.67\text{ in.}$ )  $2.67\text{ in.}$  [ $70\text{ mm}$ ], the width of the specimen shall be  $100\text{ mm}$  ( $4\text{ in.}$ )  $4\text{ in.}$  [ $100\text{ mm}$ ]. Where the thickness is greater than  $70\text{ mm}$  ( $2.67\text{ in.}$ )  $2.67\text{ in.}$  [ $70\text{ mm}$ ] the width shall be 1.5 times the thickness. Where the thickness is other than  $32\text{ mm}$  ( $1.25\text{ in.}$ )  $1.25\text{ in.}$  [ $30\text{ mm}$ ] and the specimen size is in accordance with the job thickness criteria noted in the foregoing, the average value of the test results for each condition shall be reported as the flexural modulus of elasticity of the stone at the job thickness for that condition. All other requirements shall be in accordance with 6.1.

6.3 Where the job surface finish has been set (the architectural finish on the panels for the project has been established), it is often requested to perform flexural modulus of elasticity tests on specimens with the finish the same as on the job. The following shall govern when it is requested to test at the job surface finish. The specimens shall have a finish on one plane perpendicular to the load in accordance with the finish specified for the job. Unless there are data to the contrary, the positioning of the specimen shall be with the finished face in flexural tension. The average value of the test results for each condition shall be reported as the flexural modulus of elasticity of the stone at the job surface finish for that condition. All other requirements shall be in accordance with 6.1 and 6.2.

6.4 Where the specimens conform to the requirements of 6.2 and 6.3, the average value calculated from plots of the test results for each condition shall be reported as the flexural modulus of elasticity of the stone at the job thickness and surface finish for that condition.

## 7. Conditioning

7.1 For specimens with uneven surfaces, prepare flat bearing areas for the span supports and quarter point loading blocks by applying a water resistant capping compound  $15\text{ mm}$  ( $1/2\text{ in.}$ )  $1/2\text{ in.}$  [ $15\text{ mm}$ ] wide centered on these areas. Allow the capping compound to dry or cure per the manufacturer's recommendations before continuing conditioning the specimens in accordance with 7.2 or 7.3.

7.2 Before testing the specimens in a dry condition, dry them for 48 h at  $60 \pm 2^\circ\text{C}$  ( $140 \pm 4^\circ\text{F}$ ) [ $60 \pm 4^\circ\text{F}$ ]. At the 46th, 47th, and 48th h, weigh the specimens to ensure the weight is the same. If the weight continues to drop, continue to dry the specimens until there are three successive hourly readings with the same weight. After removing the specimens from the oven, cool them to room temperature in a desiccator before testing.

7.3 Before testing the specimens in a wet condition, immerse them in water for 48 h at  $22 \pm 2^\circ\text{C}$  ( $72 \pm 4^\circ\text{F}$ ) [ $22 \pm 4^\circ\text{F}$ ]. Test them immediately upon removal from the bath, wiping the specimens free of surface water.

## 8. Procedure

8.1 Assemble the apparatus, place the specimen on the span supports, and adjust the quarter-point loading blocks into contact with the specimens.